

Cable Assembly Polarity Guide

In its simplest form, fiber polarity is the direction data/a light pulse takes from traveling through a cable, point A to point B. For polarity to be maintained and, thereby the connection between the devices achieved, a fiber optic link's transmit signal (Tx) at the end of the cable must match the corresponding receiver (Rx) at the other end.

It is important to note that the TIA-568-E standard outlines two types of fiber links: serial duplex signal connections and parallel signal (MPO/MPT) connections.

FULL-DUPLEX ASSEMBLY POLARITY MAINTENANCE

Two types of duplex fiber patch cords are defined in the TIA standards:

A-to-A type (Crossover type) – Shown in Example A below.

NOTE:

A-to-A patch cords are not commonly deployed and should be used only, when necessary, as part of a polarity method.



Example A

A-to-B type (Straight Through type) – Shown in Example B below.

NOTE:

This type is recommended by the TIA as it maintains channel-wide polarity in a duplex channel.

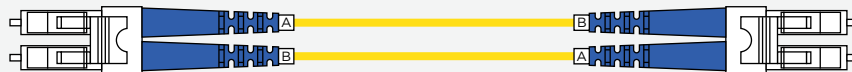

Example B

MPO/MPT ASSEMBLY POLARITY MAINTENANCE

The TIA has defined three different polarity methods to maintain fiber polarity when using multi-fiber MPO/MTP array patch cords. Each method uses different types of MPO cables: Type A, B, and C are used for the three different connectivity Methods, A, B, and C, respectively.

Method A

Method A uses **Type A** (straight-through) MPO cables with a key-up connector on one end and a key-down connector on the other end so that the fiber located in Position 1 (Tx) arrives at Position 1 (Tx) at the other end.

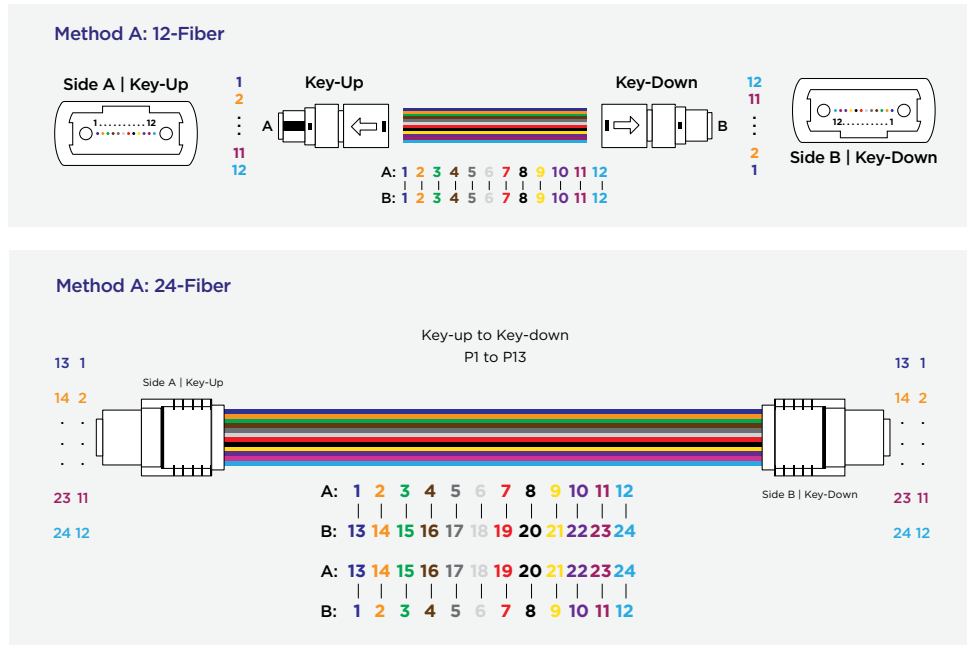

Method B

Method B uses key-up connectors on both ends to achieve the transceiver-receiver flip so that the fiber located in Position 1 (Tx) arrives at Position 12 (Rx) at the opposite end, the fiber located in Position 2 (Rx) arrives at Position 11 (Tx) at the opposite end, and so on.

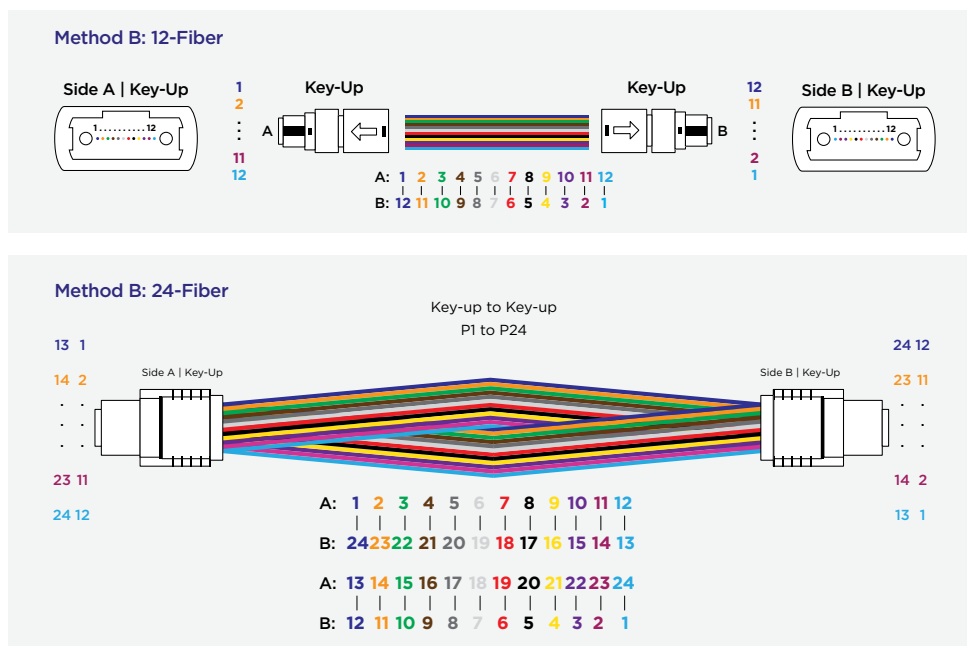

Method C

Like Method A, Method C uses a key-up connector on one end and a key-down connector on the other end. However, the flip happens within the cable itself, where each pair of fibers is flipped so that the fiber in Position 1 (Tx) arrives at Position 2 (Rx) at the opposite end, and the fiber in Position 2 (Rx) arrives at Position 1 (Tx).

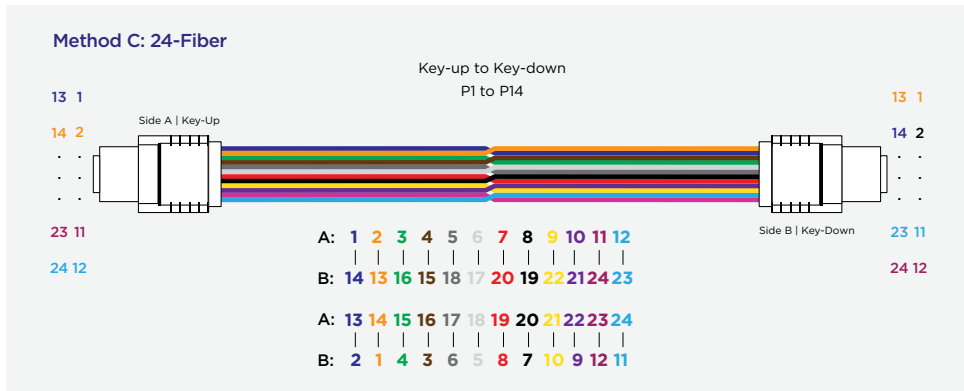
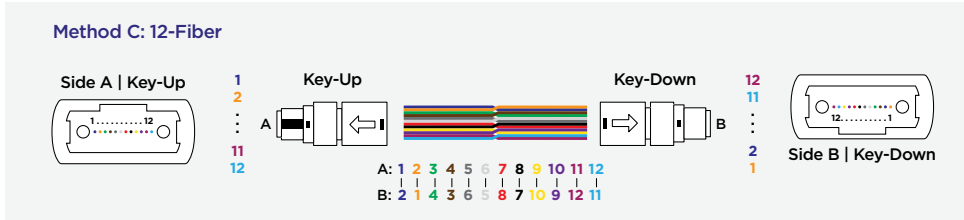

SEL Cable Assemblies

Sumitomo Electric Lightwave (SEL), an industry leader in fiber, cabling techniques, and connectorization, has one of the widest selections of cable assemblies: patch-cords, jumpers, trunks, and interconnects of any industry-leading fiber optic solutions provider.