

SUMITOMO RECOMMENDED PROCEDURE

SRP SP-F04-008



TUBE CABLE INSTALLATION PROCEDURES

PARA.	CONTENTS
1.0 2.0 3.0 4.0	General Safety Precautions Reference Documents Equipment / Tools Required
5.0 6.0 7.0 8.0 9.0 10.0 11.0 12.0	Tube Cable Reel Handling and Storage Requirements Minimum Bend Radius Requirements Maximum Allowable Pulling Tensions General Slack Requirements Thermal Slack Footage Requirements Slack Loop Techniques Excess Tube Cable Length at Splice Locations Tube Orientation at Splice Points
13.0	Indoor Tube Cable Installations
14.0 15.0 16.0 17.0 18.0	Underground Duct Tube Cable Installations Duct Preparations Installing Tube Cable in Ducts Tube Cabling Pulling Techniques Racking Tube Cable in Maintenance Holes
19.0	Direct Buried Tube Cable Installations
20.0	Aerial Tube Cable Installations
21.0	Armored Tube Cable Installations

SUMITOMO ELECTRIC LIGHTWAVE CORP.
 201 South Rogers Lane, Suite 100, Raleigh, NC 27610
 (919) 541-8100 or 1-800-358-7378
www.sumitomoelectriclightwave.com

SEL is a Member of the Sumitomo Electric Industries, Ltd. Group
Sumitomo Electric Lightwave reserves the right to improve or modify these specifications without notice.

1.0 General

1.1 This procedure describes the standard techniques for installing FutureFLEX Air-Blown Fiber (ABF) tube cable in typical indoor and outdoor (duct, direct buried, and aerial) applications.

1.2 Although actual on-site placing techniques may vary depending on site conditions, generally, tube cables are installed using standard cable installation techniques and no special tools or equipment are required.

1.3 However, there are some very important points to be considered when planning for and accomplishing a tube cable installation in order to avoid damaging the tube cables before, during, and after they are installed.

1.4 The ultimate goal is to install tube cables correctly the first time. They should be installed along properly supported, relatively bend-free, smooth flowing routes so they will pass tube pressure and obstruction tests and provide trouble-free fiber bundle blowing performance.

2.0 Safety Precautions

2.1 The use of safety equipment (safety glasses, safety shoes, gloves) is recommended during this installation procedure.

3.0 Reference Documents

3.1 Sumitomo Recommended Procedure, *FutureFLEX Tube Obstruction Testing Procedure*, SRP SP-F04-004.

3.2 Sumitomo Recommended Procedure, *FutureFLEX Tube & Tube Cable Sealing Procedures*, SRP SP-F04-019.

3.3 Sumitomo Recommended Procedure, *Installation Procedures for Liquid-Tight Kellems® Grips*, SRP SP-F04-024.

3.4 Sumitomo Recommended Procedure, *FutureFLEX Tube Cabling Splicing Procedures*, SRP SP-F04-031.

3.5 Sumitomo Recommended Procedure, *FutureFLEX Armored Tube Cable Installation Procedures*, SRP SP-F04-039.

4.0 Equipment / Tools Required

4.1 Standard cable installation hardware, equipment, and tools. No specialized equipment required.

5.0 Tube Cable Reel Handling and Storage Requirements

5.1 Perform a Receipt Inspection when a tube cable reel is received. Contact proper authority if obvious signs of damage or mishandling are noted.

5.2 Verify Lot Number, tube cable Part Number, and manufactured length information marked on outside of each flange.

Note: "DO NOT LAY FLAT" and "FORKLIFT BY FLANGES ONLY" warnings are stenciled on each flange.

5.3 Transport and store tube cable reels with their flanges vertical at all times. If placed horizontal, the weight of the upper coils can bare down and potentially compress / damage lower coil tubes.

See Fig. 1.

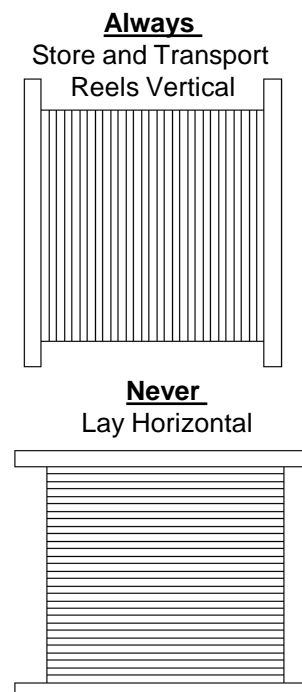

Figure 1
Tube Cable Reel Handling

5.4 Verify both ends of tube cable are sealed on the reel. Use plastic caps, plugs, or heat shrink end caps to keep interior of tube cable free of contamination. Refer to Sumitomo Recommended Procedure SRP SP-F04-019.

5.5 If tube cable must be re-spooled, ensure new reel's drum diameter is at least **20X** tube cable's OD.

5.6 Store indoor-rated tube cables indoors. If placed outdoors, cover reels with a tarp or similar. Exposure to the sun's UV rays can degrade the burn performance characteristics of the tube cable's outer jacket.

5.7 Determine size and weight of tube cable reels beforehand and arrange for appropriate handling equipment (e.g.: forklift, jack stands, etc.) to be on-site.

5.8 Handle tube cable reels with care and always safeguard against possible damage. Do not drop reels or roll for long distances.

5.9 If a tube cable is scheduled to be installed when it is cold, store the reel indoors overnight. This helps warm up the cable and makes it less stiff to install.

5.10 Set reels up so tube cables payoff from the top of the reel during installation. **See Fig. 2.**

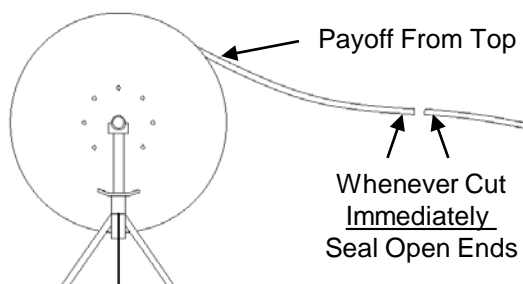

Figure 2
Tube Cable Reel Set-Up

Note: *If the condition of the tube cable on the reel is "suspect," perform a tube obstruction test while the tube cable is still on the reel. Satisfactory test results will indicate the reel has been shipped and stored correctly and that no damage has occurred to the tubes before the cable installation effort begins. See Sumitomo Recommended Procedure SRP SP-F04-004.*

6.0 Minimum Bend Radius Requirements

6.1 Determine minimum bend radius of the tube cable to be installed. Do not exceed this value or damage to the tubes and tube cable could result.

6.2 For multi-tube cables, maintain a minimum bend radius of **20X** tube cable OD when tube cable is under tension (being installed).

6.3 For multi-tube cables, maintain a minimum bend radius of **10X** tube cable OD when tube cable is relaxed (after installation and pulling force removed).

6.4 For single tubes, maintain a minimum **9"** bend radius during and after installation.

7.0 Maximum Allowable Pulling Tension

7.1 Determine the maximum allowable pulling tension of the tube cable to be installed. Do not exceed this value or damage to the tubes and tube cable could result.

7.2 If long or difficult pulls are anticipated, the weight of the tube cable and / or drag induced moving through bends in the route may result in exceeding the maximum allowable pulling tension.

7.3 Shorter pull lengths and / or additional pull points may have to be considered.

8.0 General Slack Requirements

8.1 To prevent system failure, slack footage must always be provided in any tube cable installation. This will allow for cable movements caused by thermal expansions and contractions, earthquakes or other seismic activities, accidental contact in high risk areas, and so forth.

8.2 For tube cable installations where no excess movements are anticipated (e.g.: an area where no large ambient air temperature changes occur), follow normal conventional cable racking, storage, and securing practices.

8.3 Never install a tube cable tight. Always support tube cables loosely. Manage and control where the tube cable is allowed to move by using good installation techniques.

9.0 Thermal Slack Footage Requirements

9.1 In addition to placing normal slack in a tube cable span, each segment must be evaluated for the effects of ambient air temperature changes throughout the year. If necessary, additional tube cable length for thermal slack footage must be incorporated.

9.2 **Important Point.** Use the following calculations to determine the amount of thermal slack footage required.

9.2.1 For all tube cable types except the SEL Part Number MSOS design:

$$(\Delta T) \times (\text{CSL}) \times (0.000087) = \text{Thermal Slack Footage Required}$$

- (ΔT) = Maximum temperature change (difference) in degrees Fahrenheit
- (CSL) = Cable Span or Segment Length in feet
- (0.000087) = Total Contraction Constant (or Co-Efficient of Total Contraction); a value unique to FutureFLEX tube cables and determined by SEL through testing
- Slack Footage = Extra tube cable length required for thermal changes in feet

Note: The maximum outdoor temperature change should be based on the Record High and Low temperatures for a particular region.

Example #1: Record High temperature is 95°F and Record Low temperature is 5°F; a difference of 90°F. Span length is 300'.

$$90^{\circ}\text{F} \times 300' \times 0.000087 = 2.3'$$

Example #2: Record High temperature is 110°F and Record Low temperature is -10°F; a difference of 120°F. Span length is 300'.

$$120^{\circ}\text{F} \times 300' \times 0.000087 = 3.1'$$

9.2.2 For the SEL Part Number MSOS tube cable design:

$$(\text{Ti} + 40^{\circ}\text{F}) \times (\text{CSL}) \times (0.000044) = \text{Thermal Slack Footage Required}$$

- $(\text{Ti} + 40^{\circ}\text{F})$ = Temperature at the time of installation plus 40° F
- (CSL) = Cable Span or Segment Length in feet
- (0.000044) = Total Contraction Constant (or Co-Efficient of Total Contraction); a value unique to FutureFLEX tube cables and determined by SEL through testing
- Slack Footage = Extra tube cable length required for thermal changes in feet

Example #1: Outside temperature at the time of installation is 40°F. Span length is 300'.

$$(40^{\circ}\text{F} + 40) \times 300' \times 0.000044 = 1'$$

Example #2: Outside temperature at the time of installation is 80°F. Span length is 300'.

$$(80^{\circ}\text{F} + 40) \times 300' \times 0.000044 = 1.6'$$

9.3 TOX & TOD tubing is suggested for all normal OSP environments in duct and direct buried applications below frost line.

9.4 MSOS tubing is suggested for all normal OSP environments in aerial and duct applications requiring enhanced thermal stability (i.g. on poles, refineries, industrial outdoor installations, or above frost lines/ exposed to ambient air).

10.0 Slack Loop Techniques

10.1 The extra tube cable footage necessary for general and thermal slack requirements must be properly managed to be effective.

10.2 Never install a tube cable tight. Always support tube cables loosely. Control where the tube cable is allowed to move by using good installation techniques.

10.3 Tube cable ends must be secured to TDUs to prevent cable pullout. If cable movements will be significant, it is highly recommended to use Kellems Grips to firmly anchor the ends of the tube cable. See Sumitomo Recommended Procedure SRP SP-F04-024. **See Fig. 3.**



Figure 3
Hubbell Deluxe Cord Grip (Kellems Grip)

10.4 In maintenance holes, provide as much slack as possible between duct entrances and TDU attachment points to accommodate cable movements. Do not, however, create any tight bends that could impact fiber bundle blowing performance. **See Fig. 4.**

10.5 Support outdoor tube cables using trays, J-hooks, straps, clamps, and similar standard hardware. Support spacing requirements for outdoor tube cable is every 8' or less apart. Distribute slack footage evenly along a supported route to minimize the number of bends in the span and to maximize fiber bundle blowing performance. **See Fig. 5.**

10.6 If a supported route goes around an inside corner, do not install fasteners where the tube cable approaches the corner and makes the turn. Allow the tube cable to move freely in the curve. **See Fig. 6.**

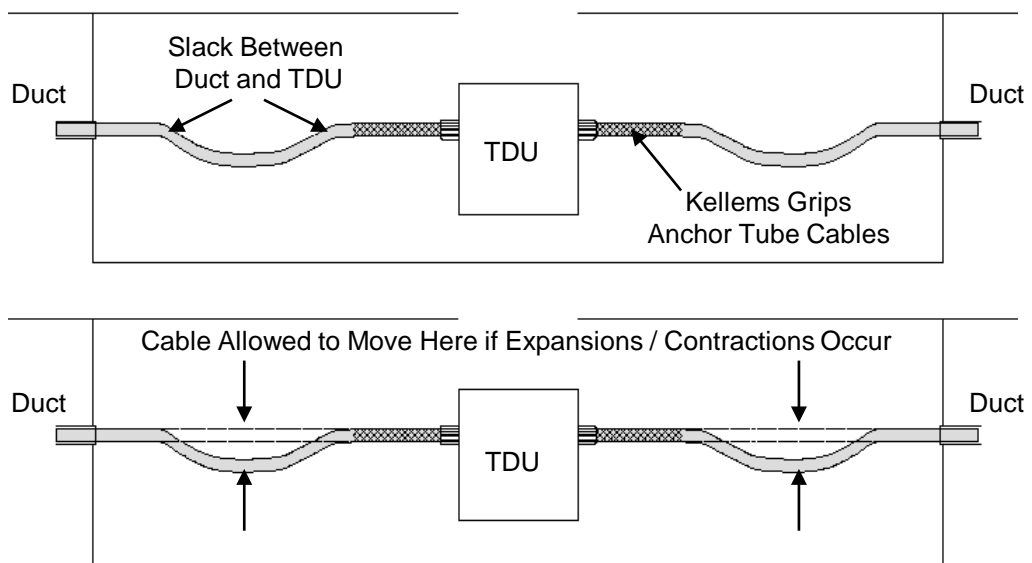

Figure 4
Managing Tube Cable Movements in a Maintenance Hole

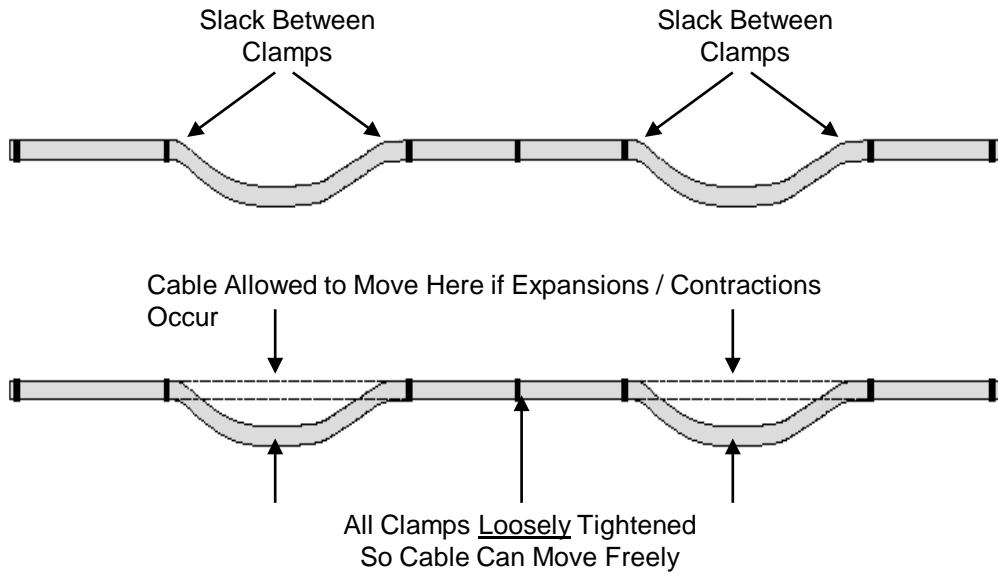

Figure 5
Managing Tube Cable Movements Along a Supported Route

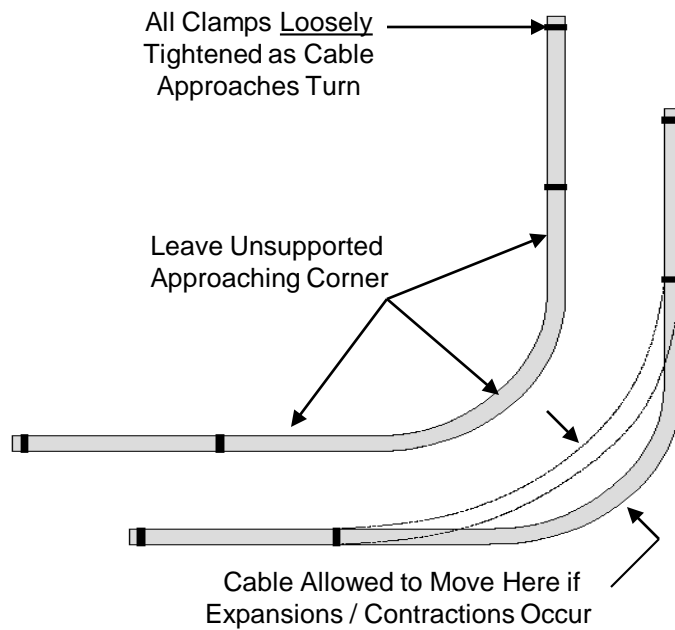
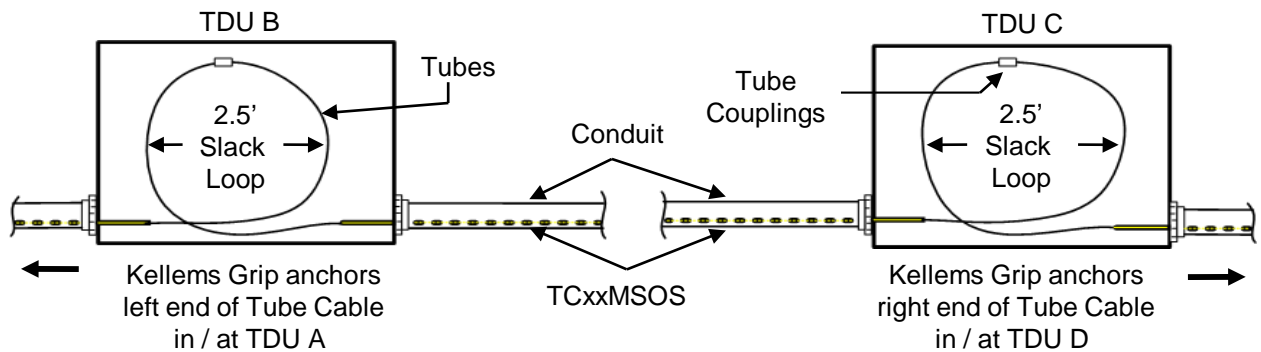
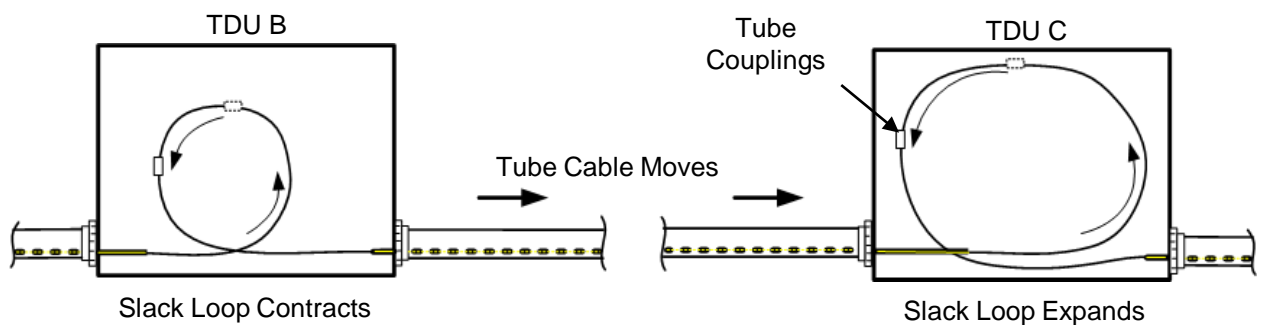

Figure 6
Managing Tube Cable Movements in a Bend or Corner

**Figure 7A**

Managing Tube Cable Slack in a Conduit Route

**Figure 7B**

Tube Cable Expansion / Contraction Movements Handled within the TDUs

10.7 In a conduit route, slack footage in tube cable runs must be planned for and provided within the various TDUs located along the route to avoid damaging the tube cable and installed fiber bundles.

10.7.1 **See Fig. 7A.** In the example above, assume an end-to-end span distance of 1000-feet from TDU A to TDU D (not shown). TDUs B and C (shown) are installed mid-run. Kellems Grips are used to anchor the ends of TCxxMSOS tube cable in or at TDUs A and D while any thermal slack will be managed within TDUs B and C.

10.7.2 The tube cable will be installed when the outside ambient temperature is 70° F. In these conditions the Thermal Slack Footage formula / calculation requires about 5.0-feet of extra slack footage.

10.7.3 Ensure the TDUs are sized properly to handle the initial slack footage required as well as any future movements. If the size of the specified TDU appears to be inadequate to handle the

calculated slack footage length requirement, a larger TDU must be used or alternative solutions employed; notify proper authority immediately.

10.7.4 During the initial tube cable installation, place equal lengths of bare tubing formed in loops within the various TDUs. In this example, install 2.5-feet in TDU B and 2.5-feet in TDU C.

10.7.5 Install Tube Couplings in the middle of the slack loop. In this position, the Tube Couplings will not be drawn or pushed inside the conduits as the tube cable moves.

10.7.6 **See Fig. 7B.** When the tube cable moves, the tubes / slack loops inside the TDUs will expand or contract avoiding damage to the tube cable and installed fiber bundles.

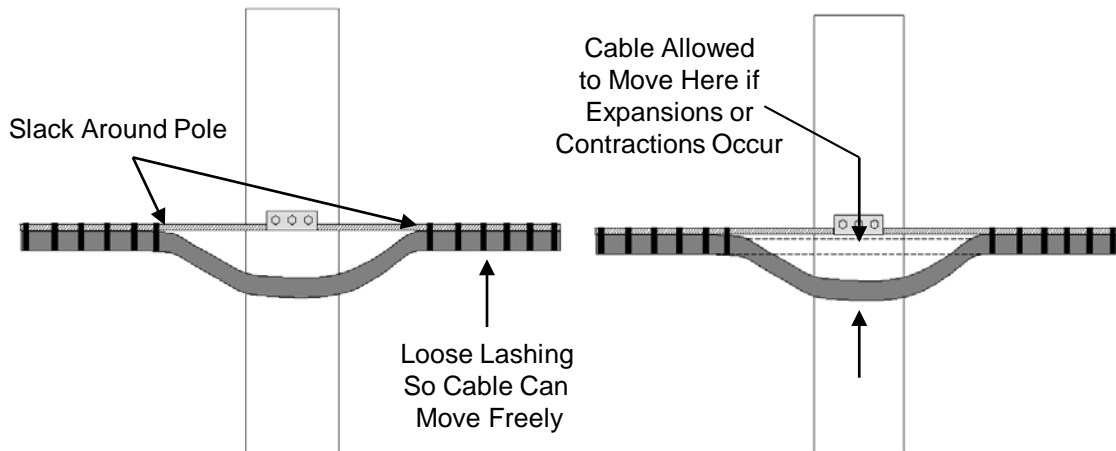

Figure 8
Managing Tube Cable Movements in an Aerial Application

10.8 In aerial applications, ensure lashing or outdoor rated cable ties are loose on either side of the pole so the cable can move at the pole. **See Fig. 8.**

11.0 Excess Tube Cable Length at Splicing Locations

11.1 In addition to normal and, if applicable, thermal slack footage requirements, a sufficient amount of extra tube cable length must be provided at each tube cable splicing location.

11.2 Typically, it is recommended to provide at least 3' of extra tube cable length at every TDU entry point for tube splicing purposes.

12.0 Tube Orientation at Splice Points

12.1 **Very Important Point.** Before installing a tube cable segment, verify that when it mates to the next tube cable segment, the tubes will not be crossed or twisted when coupled.

12.1.1 Straight-through tube connections will maximize fiber bundle blowing performance.

12.1.2 Tubes that are crossed or twisted at a splice point introduce unwanted bends in the route. The result is a *hard blowing point* that can limit blowing distances, decrease blowing speeds, and increase gas supply consumption.

Note: Tube cable jackets are length-marked every 2'; 0022 feet, 0150 feet, 0686 feet, etc. Individual tubes are numbered every 2"; 1 through 19.

12.2 Inspect the end of the installed tube cable jacket and determine if it is the Low # End or the High # End.

12.3 Inspect the end of the tube cable jacket to be installed and determine if it is the Low # End or the High # End.

12.4 If the Low # End of one tube cable will mate to the High # End of the other tube cable, when coupled, the tubes will not be crossed or twisted and the desired straight-through connection can be made. (A Low-to-High or High-to-Low condition is good.) **See Fig. 9.**

12.5 If the Low # End of one tube cable will mate to the Low # End of the other tube cable, when coupled, the tubes will be crossed or twisted and that condition is not desired. Same situation exists with a High # End mating to another High # End. (A Low-to-Low or High-to-High condition is bad.) **See Fig. 10.**

12.6 If a tube cable segment is inadvertently pulled in and then discovered that a Low-to-Low or High-to-High mating condition exists, recovery is possible. The last tube cable segment installed must be pulled out and reversed.

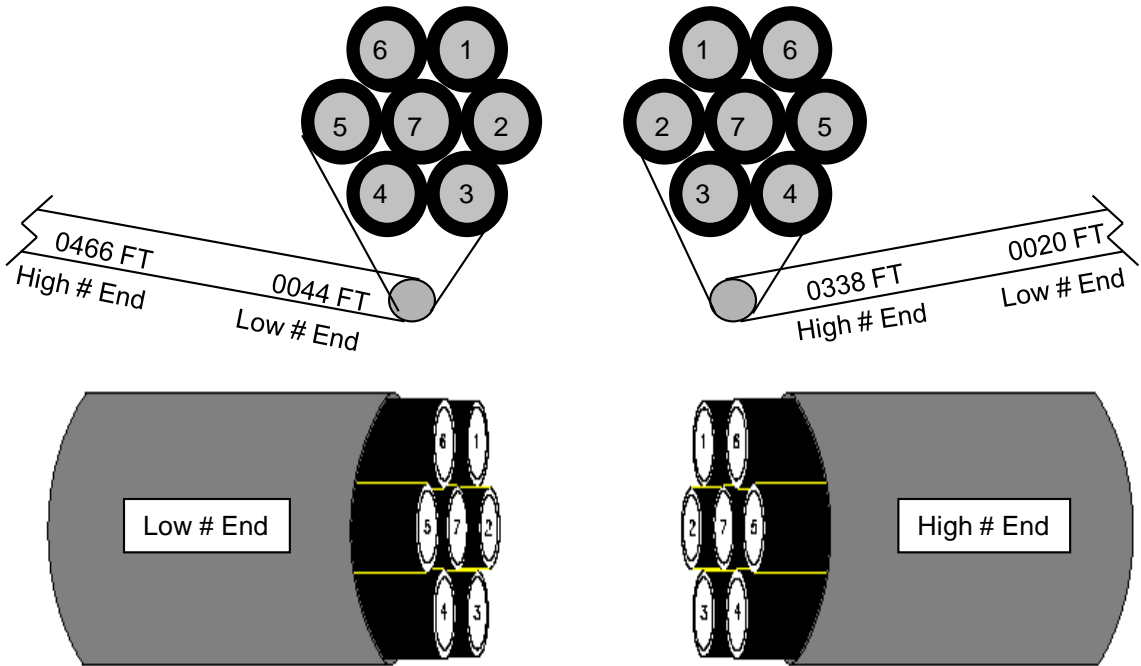

Figure 9
Correct Tube Orientation at a Splice Point
Straight-Through Tube Connections

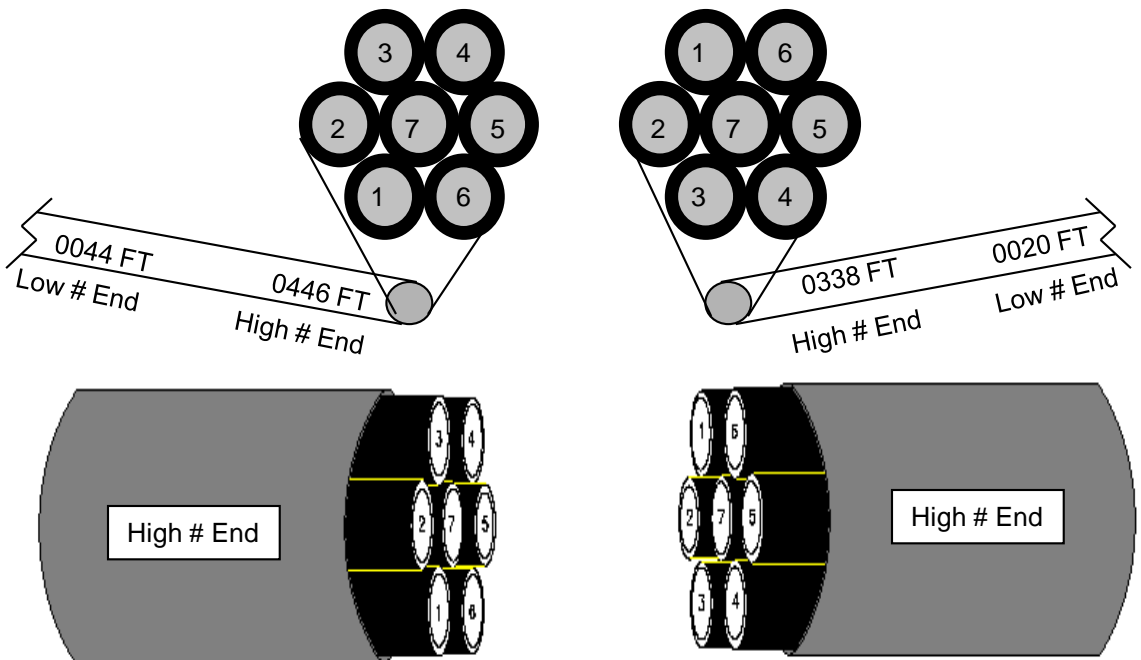

Figure 10
Incorrect Tube Orientation at a Splice Point
Tubes Will Be Crossed or Twisted When Coupled

Note: All tube cables also have small directional arrows (pointing from Low to High numbers) in their jacket print string. If the arrows will be pointing in the same direction at the splice

point, tube orientation will be correct. If the arrows will be pointing in opposite directions at the splice point, the tubes will be crossed or twisted when coupled. **See Fig 11.**

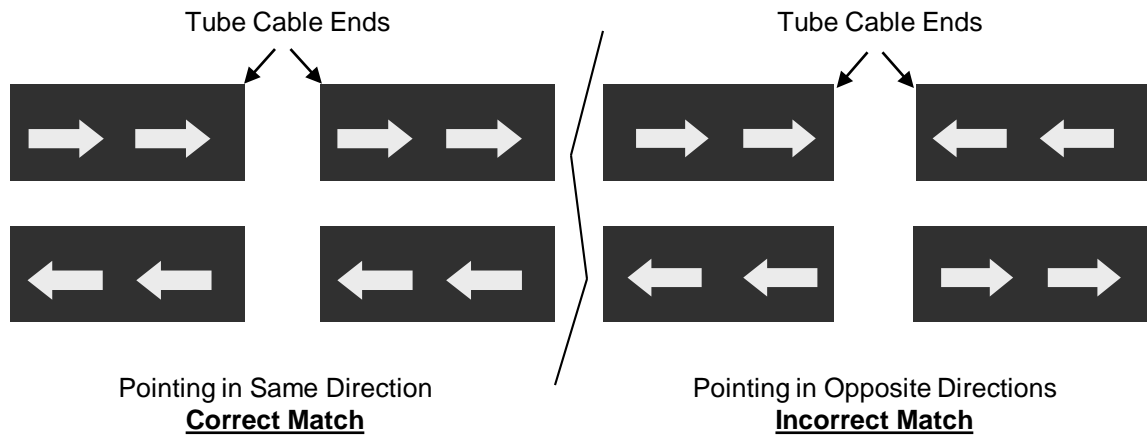

Figure 11
 Matching Print String Arrows at Tube Cable Splice Points for Correct Tube Orientation

13.0 Indoor Tube Cable Installations

13.1 Indoor tube cable installations generally follow standard indoor conventional cable installation techniques.

13.2 Support indoor tube cables using standard cable trays, J-hooks(with saddles), straps, clamps, and similar hardware. Support spacing requirements for indoor tube cable is every 5'-8' or less apart. Bridal rings and D-rings without saddles are prohibited. Do not over tighten clamps.

13.3 Observe minimum tube cable bend radius requirements of 20X tube cable OD during installation, 10X tube cable OD after installation, and 9" for single tubes at all times.

13.4 Be very conscientious of tube cable routing. Excessive bends will impact fiber bundle blowing performance. Attempt to minimize tight bends in the route as much as possible.

13.5 Avoid tight S-curves as they have the greatest negative effect on fiber bundle blowing performance. Make any S-curves as flowing and gentle as possible. Better solution is to install a straight section of run between the curves to reduce friction / drag on the moving fiber bundle. **See Fig. 12.**

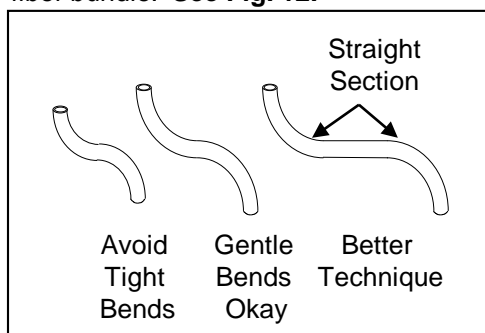

Figure 12
 Avoid Tight S-Curves

13.6 Inside buildings, inspect tube cable installation routes carefully. If tube cable must be pulled over support members, ladder rungs, angle iron, and the like, sharp edges could easily damage the tubes and jacketing.

13.6.1 Install some type of hard and rounded temporary protective covering (e.g.: Split Innerduct, a Roller Wheel, a temporary Waterfall or Bridge product, etc.) over all sharp points if there is any chance the tube cable will come in contact with them. **See Fig. 13.**

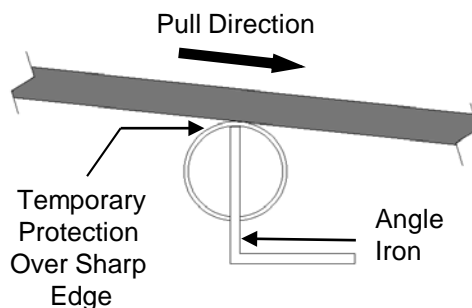

Figure 13
 Protecting Tube Cable During Installation

13.6.2 Make sure the protective devices are firmly attached so they will not be pulled loose as the tube cable moves across it.

13.6.3 If the tube cables will remain on these sharp points, install a permanent Waterfall or Bridge product.

13.7 If long vertical unsupported runs are encountered, such as in a Riser application, support the tube cable about every 100' by securing it with a Support Device such as a Kellems Support Grip or equal. This technique takes the weight of the tube cable off itself and avoids potential stretching and straining damage to the tubes.

14.0 Underground Duct Tube Cable Installations

14.1 Prior to installing tube cables in an underground duct system, an inspection of the job site should be conducted.

14.2 Verify location, type, size, and distances between all maintenance holes, vaults, pull boxes, etc. along the route.

14.3 Verify type and size of designated duct.

14.4 Verify route orientation of designated duct and determine if it is straight or contains sweeping or tight bends. (Minimum bend radius is 20X tube cable OD during installation.)

14.5 Use the following calculations to determine if Conduit Fill Ratio is adequate. Wherever possible, avoid exceeding the standard 40% fill ratio.

$$d^2 \div D^2 < 40\%$$

or

$$(d_1^2 + d_2^2 + d_3^2) \div D^2 < 40\%$$

- d = Diameter of tube cable or cables
- D = Diameter of conduit

Example #1: Single Tube Cable. Tube cable diameter is 1.1" Conduit diameter is 2.0".

$$1.1^2 \div 2^2 = 30\% \text{ (Good / less than 40\%)}$$

Example #2: Multiple Tube Cables. Tube cable diameters are 1.7", 1.7", and 1.7". Conduit diameter is 4.0".

$$1.7^2 + 1.7^2 + 1.7^2 \div 4^2 = 54\% \text{ (Exceeds 40\%)}$$

CAUTION: Always test the air quality of an enclosed space before entering. Hazardous / poisonous gases may exist and must be completely exhausted before personnel are allowed to enter.

14.6 Inspect all maintenance holes for water and test for harmful gases. Ensure appropriate equipment is on hand to drain and ventilate as required.

14.7 Where required, provide safety devices such as fences, safety cones, sign posts, warning lights, and so forth as a means of safeguarding against moving vehicles and pedestrians.

14.8 Provide appropriate lighting if installation work will be performed at night or if an excavated trench will be left open overnight.

14.9 Provide means to protect all previously installed cables to avoid damaging them during tube cable installation.

15.0 Duct Preparations

Prior to installing tube cable, the condition of the underground duct must be ascertained and, if necessary, cleared and cleaned. This is particularly important if the duct system has been in place for a long period of time.

15.1 Rodding

Rodding is a technique used to clear a duct and install a pulling rope (or tape). It can be performed using either a steel or fiberglass / plastic rod or with an air-blowing device.

15.1.1 Push rod into duct until front end reaches adjacent maintenance hole.

15.1.2 Attach pulling rope to front end of rod and pull rod and rope back through and out of duct entrance. **See Fig. 14.**

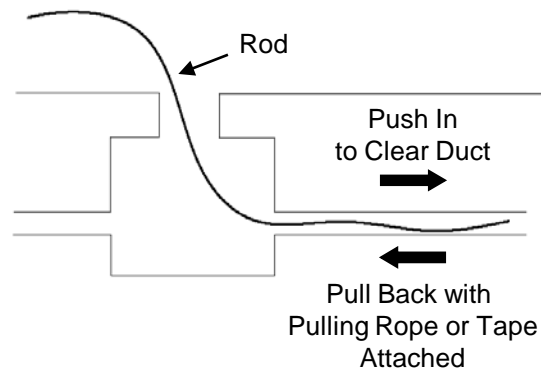

Figure 14

Rodding with a Steel or Plastic Rod

15.1.3 If air-blowing method is used, pulling rope is attached to an air pressure device and blown through the duct until it reaches the adjacent maintenance hole. **See Fig. 15.**

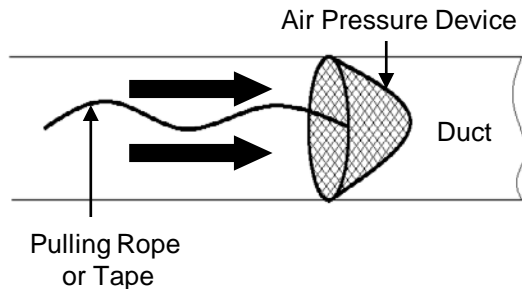

Figure 15
Air-Blowing Method of
Installing Pulling Rope or Tape

15.2 Duct Cleaning

The interior of the duct should be cleaned to ensure there are no obstacles that would prevent easy installation of the tube cable.

15.2.1 Attach a wire brush, rags and a second pulling rope to one end of previously installed pulling rope. Ensure cleaning apparatus and second pulling rope are securely attached to first pulling rope and won't come loose. **See Fig. 16.**

15.2.2 Pull cleaning apparatus through duct. Repeat if necessary.

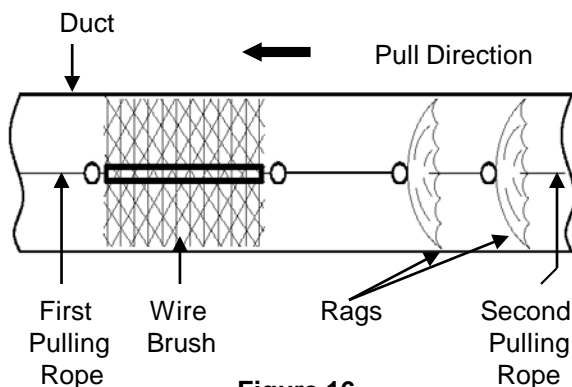

Figure 16
Cleaning Duct Interior with
Wire Brush and Rags

15.3 Mandrel Passing Test

This test is performed on ducts (excluding concrete pipes and asbestos cement pipes) whenever the possibility of tube cable damage exists as a result of duct condition (e.g. possibly collapsed).

Note: *Wooden mandrel diameter should be about 10% smaller than duct's diameter.*

15.3.1 Attach front end of mandrel to first pulling rope and back end of mandrel to a second pulling rope and pull through duct.

15.3.2 Mandrel testing may be performed simultaneously with the duct cleaning process if desired.

Note: *Since the wooden mandrel's diameter is only slightly smaller than that of the duct's diameter, the mandrel may not be able to easily pass through the duct. If such difficulty arises, a Cable Sample Scratch Test should be performed to ascertain the duct's condition.*

15.4 Cable Sample Scratch Test

If the Mandrel Passing Test fails, a Cable Sample Scratch Test may have to be performed to determine the duct's condition and ability to pass a tube cable with damaging it.

15.4.1 Obtain a two-meter sample of the tube cable to be installed.

15.4.2 Paint or coat test cable's outer jacket with black enamel to aid in the visual inspection for scratches after tube cable is pulled through duct.

15.4.3 Attach swivel-equipped pulling grips to both ends of the test cable to prevent it from twisting during the pull.

15.4.4 Attach front end of test cable to the installed pulling rope and the back end of the test cable to a second pulling rope and pull through duct.

Note: Mandrel and Scratch testing provide methods of determining duct condition, its effect on the tube cable, and the probability of a smooth tube cable installation. If these tests fail, use of an alternate duct or repair of the designated duct should be performed after consulting with proper authority.

Note: In the case of a newly installed duct or when the duct's inner diameter is comparatively larger than the tube cable diameter, some of the processes mentioned above may be eliminated unless otherwise specified in the Cable Placement Contract.

16.0 Installing Tube Cable in Ducts

After duct condition has been determined, tube cable pulling operations can begin.

16.1 Tube Cable Reel Set-Up

16.1.1 Verify tube cable Lot Number, Part Number, and length-on-reel information stenciled on reel flanges matches installation plans.

16.1.2 **Important Step.** Verify tube cable pull direction to ensure individual tubes of one tube cable segment will splice to next tube cable segment in the same orientation.

16.1.3 Position tube cable reel so that it is on the same side of the maintenance hole as the direction of the pull with cable payoff from the top. **See Fig. 17.**

16.1.4 Use standard reel trailer or jack stands to stabilize tube cable reel to a horizontal level.

CAUTION: Never pull tube cable through duct unless tube cable end is properly sealed.

16.1.5 **Important Step.** Verify tube cable end is sealed to prevent contamination from entering open tubes during the pull. See Sumitomo Recommended Procedure SRP SP-F04-019 for appropriate sealing techniques.

16.1.6 During the installation, always have one or two Installers stay with the reel to help guide and push the tube cable into the duct.

16.1.7 It is strongly recommended to apply a pulling lubricant to the tube cable's outer jacket to reduce pulling friction and drag.

Note: Any standard cable pulling lubricant can be used on FutureFLEX tube cables.

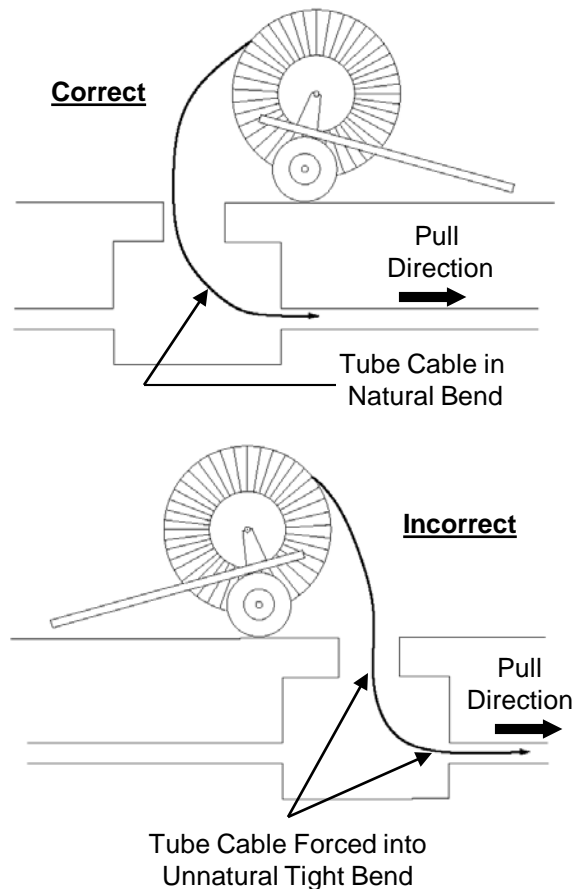

Figure 17
Tube Cable Reel Placement

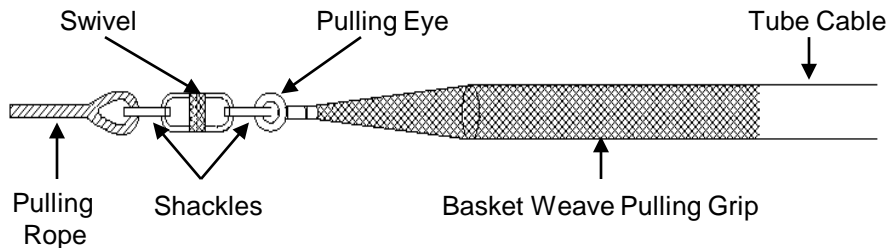

Figure 18
Standard Pulling Grip Attachment Method

16.2 Attachment of Pulling Rope

16.2.1 The pulling end of the tube cable must be properly prepared to endure the pulling tensions encountered during installation. The typical method for attaching a pulling rope to a tube cable end is with standard basket weave style pulling grip. **See Fig. 18.**

16.2.2 After securing the pulling grip to the tube cable end, connect the pulling rope with a quality-made swivel and shackles.

16.2.3 A swivel should always be used between the pulling grip and pulling rope to prevent tube cable from twisting during installation and possibly damaging interior tubes.

16.2.4 Use of a breakaway swivel is strongly recommended. The rating of the breakaway swivel should be less than the tube cable's maximum allowable pulling tension. Should tube cable inadvertently hang up during the pull, the swivel will part thus preventing tube cable damage.

17.0 Tube Cable Pulling Techniques

Manual and slip winch pulling are generally the two most commonly used methods to install tube cable. Specialized techniques such as bi-directional and section pulling can also be used, especially if a long or difficult span must be installed.

17.1 Manual Pulling Method

17.1.1 A typical Manual Pulling set-up and operation is shown in **Fig. 19.**

17.1.2 Have at least one Installer in each maintenance hole to pull tube cable through the duct.

17.1.3 In curved installations, use two Installers in a maintenance hole to help negotiate the turn and prevent tube cable from being kinked.

17.1.4 If available, use Large or Small Pulling Shoes to help tube cable negotiate turns and exposed bends. Ensure minimum bend radius requirement of 20X tube cable OD is maintained with respect to the size / radius of Large Pulling Shoe or placement of Small Pulling Shoes. **See Fig. 20 and Fig. 21.**

17.1.5 Always pull tube cable in a straight direction without bending. If needed, special gripping gloves are available to facilitate pulling lubricated tube cables. **See Fig. 22.**

17.1.6 Good communication and coordination between Installers is essential so the pulling action can be achieved in a synchronized movement.

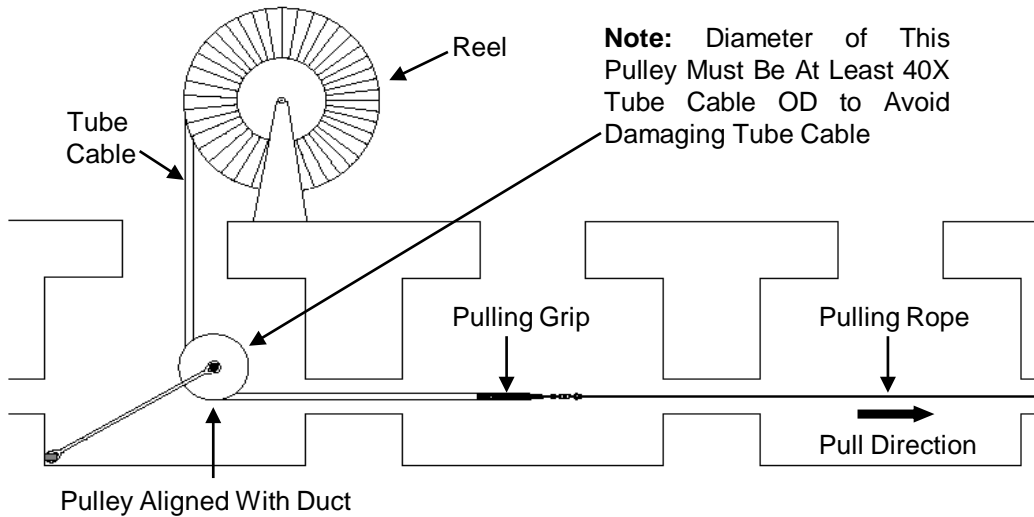

Figure 19
Manual Pulling Method

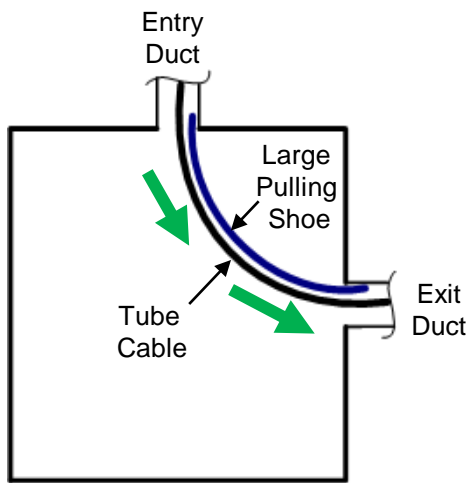

Figure 20
Pulling Tube Cable Through Exposed Bends

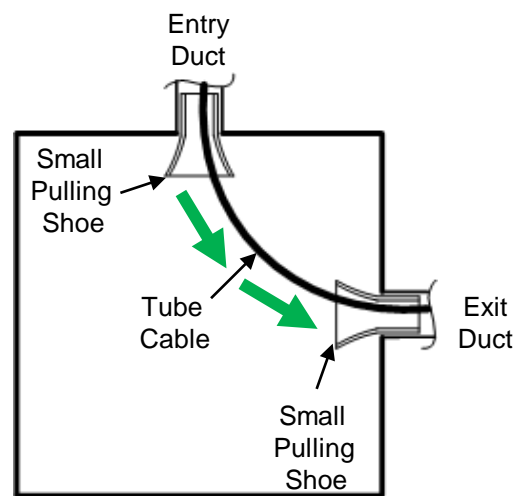

Figure 21
Pulling Tube Cable Around Corners

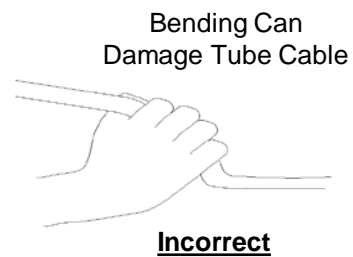
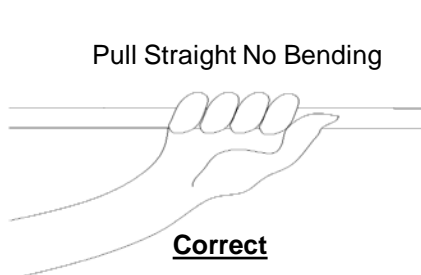

Figure 22
Correct Tube Cable Pulling Technique

17.2 Slip Winch Method

17.2.1 A typical Slip Winch set-up and operation is shown in **Fig. 23**.

17.2.2 The slip winch is set up at the maintenance hole to which the tube cable is being pulled to (i.e.: take-out maintenance hole).

17.2.3 Pulleys are installed and aligned with the duct to guide the pulling rope from the duct, out of the maintenance hole opening, and up to the driving wheel on the slip winch.

17.2.4 The pulling rope is wrapped around the driving wheel with several turns. When activated, the driving wheel pulls the pulling rope that pulls the tube cable through the duct.

17.2.5 The pulling tension at the slip winch should be set to an amount below the tube cable's maximum allowable pulling tension and closely monitored during operations.

17.2.6 If available, use Large or Small Pulling Shoes to help tube cable negotiate turns and exposed bends. Ensure minimum bend radius requirement of 20X tube cable OD is maintained with respect to the size / radius of Large Pulling Shoe or placement of Small Pulling Shoes. **Refer to Fig. 20 and Fig. 21.**

17.2.7 Good communication and coordination between Installers is essential so that the pulling action can be achieved in a synchronized movement.

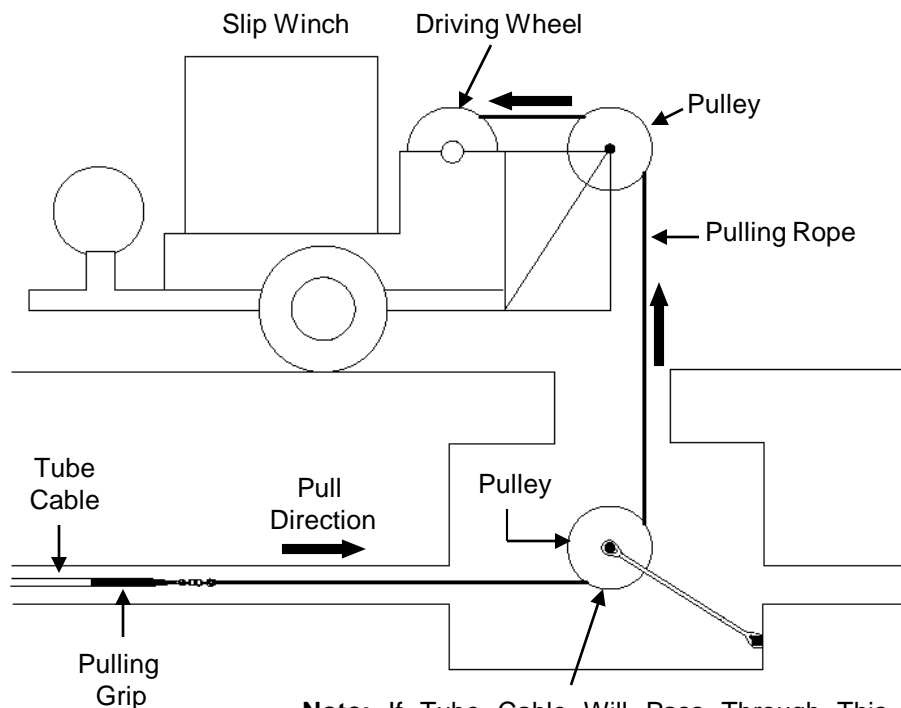

Note: If Tube Cable Will Pass Through This Pulley, Diameter of Pulley Must Be At Least 40X Tube Cable OD to Avoid Damaging Tube Cable

Figure 23
Slip Winch Pulling Method

18.0 Racking Tube Cable in Maintenance Holes

18.1 Generally, tube cables should be installed in as straight a route as possible to enhance fiber bundle blowing performance.

18.2 However, racking a tube cable in a maintenance hole should be done if:

- Cable may be stepped on or damaged as personnel enter maintenance hole
- TDU or Splice Case placement creates sharp bends in tube cable routing
- It will facilitate easier more effective installation
- It will allow for changes in the future
- Duct entry / exit locations create sharp bends in tube cable routing

18.3 Tube cable can be curved around the outer walls of the maintenance hole but exercise care. Stay within the minimum bend radius requirement of 10X tube cable OD after installation.

18.4 Protect exposed tube cable. Loosely strap to existing cables or structural members located along outer walls of maintenance hole.

18.5 Avoid sharp bends within 3' of duct entry.

19.0 Direct Buried Tube Cable Installations

All FutureFLEX outside plant tube cable designs are capable of being direct buried. The armored designs are preferred as they will preclude cable damage during installation, provide additional support, and offer rodent protection.

19.1 Tube cables must be buried below local frost-line where the cable is not subject to ground heaving effects. Additionally, below-frost line, ground temperatures are relatively stable year round.

19.2 Any trench used for burying tube cables must be as flat as possible. Undulations will cause unnecessary tube cable bends that could impact fiber bundle blowing performance.

19.3 Marker tape should be placed about 1' - 2' above the buried tube cable. This tape can be purchased with metallic conductor for easier location of the nonmetallic tube cables.

19.4 If an open trench method is used, the recommended technique is shown in **Fig. 26**:

- Dig to required depth (below frost line)
- Add 4" - 6" layer of gravel for drainage
- Add 4" - 6" layer of compacted sand
- Place tube cable in center of trench
- Add another 4" - 6" layer of compacted sand
- Backfill trench being careful to screen out large rocks and debris

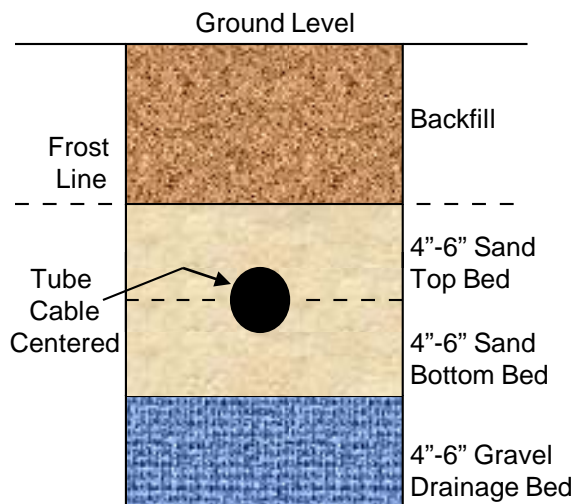

Figure 26
Direct Buried Tube Cable

20.0 Aerial Tube Cable Installations

Aerial or overhead tube cables are installed using methods similar to other telecommunications cables installations.

20.1 Aerial installations are typically the worst case scenario for thermal expansion and contraction effects. The recommended tube cable type for aerial installations is SEL P/N TCxxMSOS. This cable has been designed with enhanced thermal performance characteristics and stability in its outer jacket and tubes.

20.2 Before installing tube cables in aerial environments, it is imperative that careful consideration be given to cable slack management issues.

20.2.1 Thermal slack footage requirements must be calculated for each span. Formulas were presented earlier in this SRP.

20.2.2 Slack storage locations must be designated within each span.

20.2.3 The proper hardware for maintaining slack loops must be used. The use of Kellems Grips is highly recommended to anchor the ends of the tube cable to a TDU. Refer to Sumitomo Recommended Procedure SRP SP-F04-024.

20.2.4 Slack loops at poles are required to accommodate thermal expansion and contraction movements. Loosen lashing or cable ties about 1-1/2' from either side of the pole to allow slack loop to move easily. **See Fig. 27.**

20.2.5 Splicing or cable slack loops which are designed into the system should be left well out of the climbing space and clearly marked with fiber optic warning tags.

Note: FutureFLEX tube cables are not available with an integral or Figure 8 messenger.

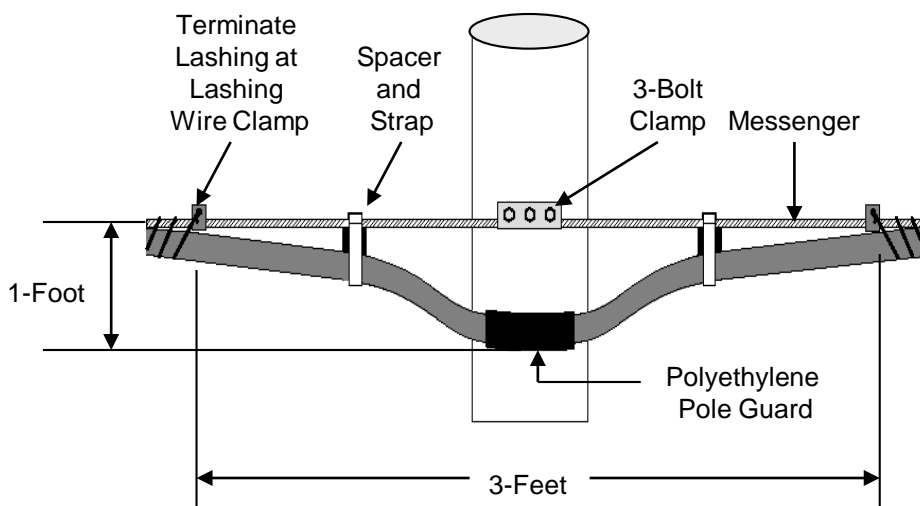

Figure 27

Tube Cable Aerial Installations Around Poles

20.3 Tube cable can be installed with a drive-off method and lashed to new strand using a standard lashing machine and telecommunications standard 430 grade lashing wire. **See Fig. 28.**

NOTE: *During drive-off installations, the tube cable is fed from a reel on a moving truck and lashed as it is installed. In order to perform this method of installation, the pole must be free of lower obstructions.*

20.3.1 Single lashing should be used if installing lighter weight 2-, 4-, and 7-tube cable designs.

20.3.2 Double-lashing should be used if installing heavier weight 19-tube cable designs;

tube cables weighing more than 100 lbs. per 1000'.

20.4 Tube cables can be over-lashed to pre-existing strand or other cables provided the existing cable is capable of withstanding the added load.

20.5 Tube cables can be installed with outdoor rated cable ties or straps spaced every 12"-18" apart. Ensure the hardware used is of proper load rating and installed so it does not cut or damage the tube cable.

20.6 Pulling machines designed to pull fiber optical cables can be used to install tube cables and are recommended to enhance installation productivity.

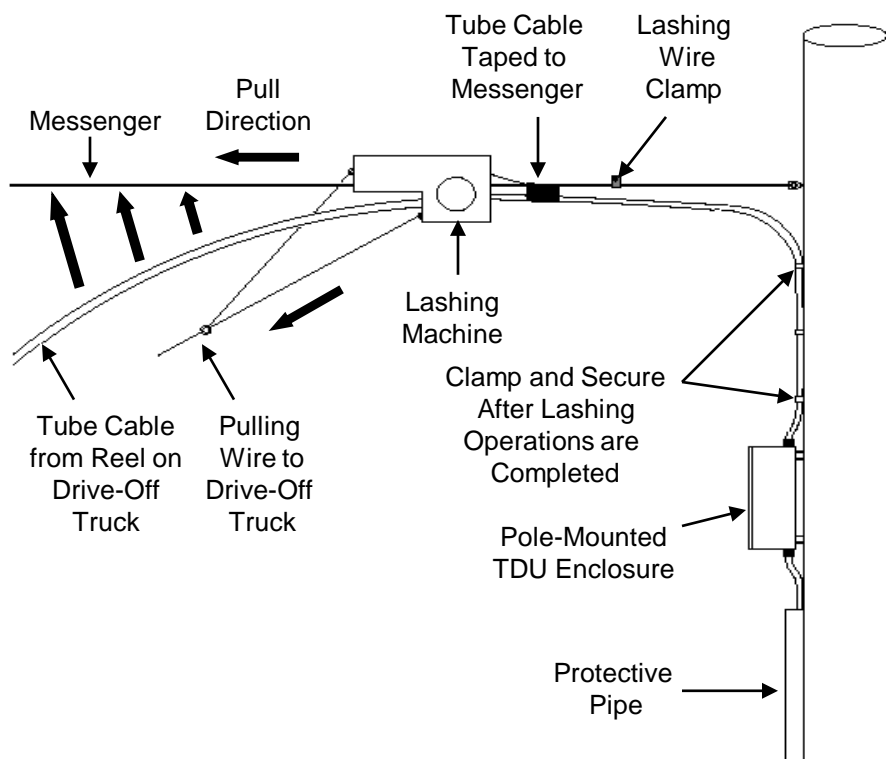

Figure 28
Drive-Off Method for Aerial Installation with a Lashing Machine

20.7 When pulling tube cable onto rollers, maximum allowable pulling tension and minimum bend radius should be closely monitored to ensure that the installation does not exceed allowable limits.

20.7.1 Roller assemblies should be placed at all strategic locations including in bends in excess of 45-degrees.

20.7.2 Rollers or similar type of pole guards should be placed on any poles that contact the cable to prevent damage.

20.8 Use a flexible PVC or PE pipe to provide added protection to the tube cable as it transitions off the pole.

21.0 Armored Tube Cable Installations

Special procedures and techniques are required to correctly install FutureFLEX Air-Blown Fiber (ABF) Interlocked Galvanized Steel armored tube cables in indoor and outdoor (duct and direct buried) applications.

21.1 Dash -1 tube cable Part Numbers identify a core tube cable with a ruggedized Interlocked Galvanized Steel wrap without a Polyethylene (PE) outer jacket. The Dash -1 designs are only used in indoor applications with General Purpose-, Riser-, or Plenum-rated tube cables. .

21.2 Dash -2 tube cable Part Numbers identify a core tube cable with a ruggedized Interlocked Galvanized Steel wrap with a Polyethylene (PE) outer jacket. The Dash -2 designs are typically used in outdoor applications with all Dielectric and Metallic tube cable designs.

21.3 Refer to Sumitomo Recommended Procedure, *FutureFLEX Armored Tube Cable Installation Procedures*, SRP SP-F04-039.