

SUMITOMO RECOMMENDED PROCEDURE**SP-F04-053****Procedure For Lubricating Tubes
For FP48PVS & FP72PVx
Fiber Bundle Installation**

PARA.	CONTENTS
1.0	General
2.0	Safety Precautions
3.0	Equipment / Tools Required
4.0	Setup
5.0	Procedure

SUMITOMO ELECTRIC LIGHTWAVE CORP.
201 South Rogers Lane, Suite 100, Raleigh, NC 27610
(919) 541-8100 or 1-800-358-7378

www.sumitomoelectricleightwave.com

SEL is a Member of the Sumitomo Electric Industries, Ltd. Group

Sumitomo Electric Lightwave reserves the right to improve or modify these specifications without notice.

1.0 General

This document describes the procedure for installing Sumitomo's FutureFlex 72 fiber bundles. The jacketing for the 72 fiber is PVDF rather than PEF used for the lower fiber bundle counts. The 72 therefore requires prelubrication of the tubing pathway for best blowing performance. The bundles are OFNR rated for Riser, General Purpose, and all OSP tube cabling applications.

After following this procedure, set up the blowing head as described in SRP SP-F04-001. Then, continue to SRP SP-F04-002 (Section 8) for fiber bundle installation.

2.0 Safety Precautions

2.1 Pressurized nitrogen (N₂)

The use of a pressurized nitrogen gas source presents several safety concerns. N₂ is a simple asphyxiate. If large amount of nitrogen are released into a confined area, the nitrogen can displace the amount of oxygen in air necessary to support life.

2.2 Transporting and handling pressurized nitrogen bottles

- Any pressurized gas cylinder is dangerous if damaged.
- Gas bottles must be properly capped when being transported
- Gas bottles must be secured to a stable pressure bottle dolly or chained to a structure when uncapped for use (Figure 1).
- A full bottle of nitrogen weighs approximately 160 lbs. Two persons are needed when any manual lifting or moving of a bottle. Remember to exercise care and use proper lifting techniques.

2.3 Polywater PreLube 5000 Lubrication Safety

- Although PolyWater is not toxic or carcinogenic, direct eye contact or prolonged skin exposure may cause irritation. Read the SDS online for more information.



Figure 1
Strapped and Capped Nitrogen Tank

3.0 Equipment / Tools Required

The following equipment, tools, and materials are required to complete this procedure:

1. Pressure Regulator with 8 mm Tubing Adapter (Figure 4)
2. 8 mm Jumper Tube
3. Motor Rate Control Valve (Figure 5)
4. Nitrogen Tank
5. Open ended wrench (Figure 2)
6. Polywater® Prelube™ 5000 Microcable Blowing Lubricant (BELUBE8)
7. Lubricant Sponges (BESPG01)
8. Syringe (BESRG20)



Figure 2
Wrench used to tighten pressure regulator

4.0 Setup

4.1 Ensure pressurized gas bottle is securely chained / strapped in place and remove Safety Cap.

4.2 Thread Pressure Regulator fitting onto bottle valve housing and tighten with large open ended adjustable wrench. See Fig. 2.

Note: Do not use serrated jaw tools (e.g.: pipe wrench, vise grips, channel locks, etc.) to tighten brass nut of Pressure Regulator.

4.3 With Pressure Regulator Valve open, open Bottle Supply Valve and check for leakage around fitting (Figure 3). If leakage is detected, close Bottle Supply Valve and retry tightening with wrench. If unsuccessful, regulator must be replaced.

4.4. Close Bottle Supply Valve.

4.5 Install male quick-disconnect 8 mm Tubing Adapter into female quick-disconnect fitting on Pressure Regulator. Turn in on Pressure Regulator Valve to vent Pressure Regulator (both Gauges read zero).

4.6 Attach jumper tubing to Motor Rate Control Valve (Bypass switch can also be used) provided in Blowing head or ordered separately. See Figure 5.

4.7 Attach jumper tubing from motor rate control valve to the designated route for 72 fiber bundle installation. Tubing and equipment should look like Figure 6 on the next page.

5.0 Procedure

5.1 Turn on pressure regulator to 60 psi and open motor rate control valve to put air on the line and verify that you and the person on the end of the route are on the correct tube. Then shut off air and close motor rate control valve.

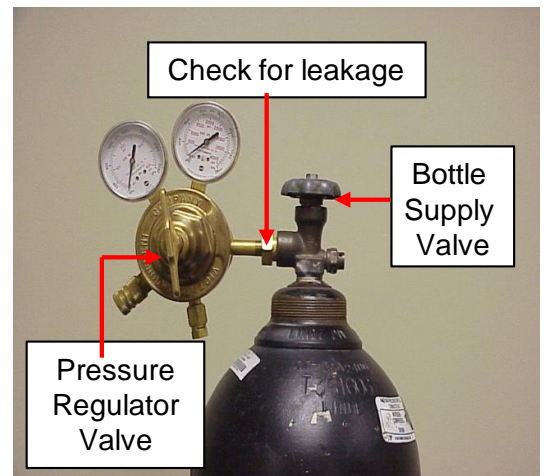

Figure 3
Pressure Regulator Connected to Gas Bottle



Figure 4
Pressure regulator with 8mm tubing adapter

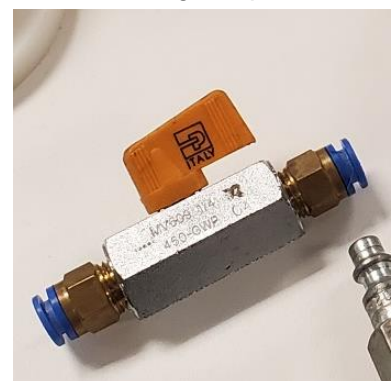

Figure 5
Motor Rate Control Valve

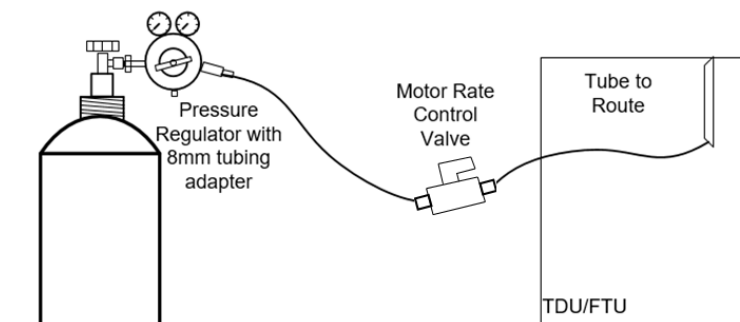

Figure 6
Tubing and Equipment Setup

SEL Part #	Name	U/M
BELUBE8	Tube cable lubricant, 8-fl oz./240-ml squeeze bottle	EA
BESPG01	Sponges for spreading lubricant, 5-8 mm, pack of 100	PK
BESRG20	Polypropylene Syringe 20ml	EA

5.2 Uncouple tubing from the motor rate control valve leading to the route.

5.3 Take BELUBE8 and insert 10mL into syringe.

5.4 Use syringe to measure out and funnel 10 mL per 1000' of tubing of PreLube 5000 into the tubing line.

5.5 Twist sponge and fit into tubing behind the lubrication loaded previously.

5.6 Connect the tubing line loaded with lubrication and a sponge to the motor rate control valve.

5.7 Alert person on the other end of the route that the sponge is loaded.

5.8 Turn on the pressure regulator to 60 psi.

5.9 Turn the motor rate control valve to put air on the line

5.10 Wait to be alerted for sponge exiting other side

5.11 If sponge exits dry- repeat process until sponge comes out the exit point moist.

5.12 Follow blowing head setup and fiber bundle installation procedures as detailed in SP-F04-001 and SP-F04-002.

NOTE: Make sure to lubricate tube within 1 hour of time the blowing of fiber will commence.