

SUMITOMO RECOMMENDED PROCEDURE**SRP SP-F04-048****Field Termination Kit Procedure For
FT48FBK & FT72FBK to Fox Cassette**

| PARA. | CONTENTS |
|--------------|---|
| 1.0 | General |
| 2.0 | Safety Precautions Reference |
| 3.0 | Documents Equipment / Tools |
| 4.0 | Required FOX cassette description and |
| 5.0 | components |
| 6.0 | Installation for 12 and 24 fiber Ribbon FOX Cassettes |
| 7.0 | Installation for 12 and 24 fiber Tight Buffer FOX Cassettes |

SUMITOMO ELECTRIC LIGHTWAVE CORP.
201 South Rogers Lane, Suite 100, Raleigh, NC 27610
(919) 541-8100 or 1-800-358-7378

www.sumitomoelectriclightwave.com

SEL is a Member of the Sumitomo Electric Industries, Ltd. Group

Sumitomo Electric Lightwave reserves the right to improve or modify these specifications without notice.

1.0 General

1.1 This procedure describes the standard techniques for installing the Sumitomo Electric Lightwave(SEL) FT48FBK or FT72FBK Field Termination Kit to a 12 or 24 fiber ribbon Fox Cassette.

1.2 The Field Termination Kits are used at locations where fiber bundles containing Freeform Ribbon™ are to be terminated to MPO Splice-On-Connectors (SOC) or Fiber Optic eXchange (FOX) Cassettes. Before beginning make sure you have the right connector type, count, and mode designation on your FOX cassette for your application.

2.0 Safety Precautions

2.1 Wear safety glasses when working with bare optical fibers / fiber ribbons.

3.0 Reference Documents

3.1 Sumitomo Recommended Procedure,

- *FutureFLEX PVDF Fiber Bundle Stripping Procedure SRP SP-F04-045*
- *Field Termination Kit Procedure For FT72FBK Ribbon Breakout SRP SP-F04-046*
- *Field Termination Kit Procedure For FT72FBK 900µm Sub-Unit Kit SRP SP-F04-047*
- *FreeForm Ribbon Matrix Removal Procedure SRP SP-F04-050*

4.0 Equipment / Tools Required

The following equipment, tools, and materials are required to complete this procedure:

4.1 Freeform Ribbon™ 48 or 72 fiber bundle already installed into a FT48FBK or FT72FBK Field Termination Kit.(either single or ribbon furcation's)

4.2 **FOX cassette that has the correct designation to match breakout kit (ribbon or tight buffer)** as well as mode, fiber count, and connector type.

4.3 Clean Work Surface

4.3 Safety glasses for working with bare fiber.

4.4 Clean Work Surface / Table

4.4 Clean Work Surface / Table

4.5 Mass or single fiber fusion splicer and accessories (cleaver, strippers, etc.)

5.0 FOX Cassette Description and Components

5.1 After terminating a 48 or 72 fiber bundle into a breakout kit, you will need a total of two to four cassette boxes for the 48 fiber bundle and three to six cassette boxes for the 72 fiber bundle.

A 48 fiber bundle will require four 12 fiber cassettes or two 24 capacity cassettes.

A 72 fiber bundle will require three 24 fiber capacity cassettes, or six 12 fiber capacity cassettes.

Note: To Terminate a 72 fiber bundle using a Field Termination Kit (FT72FBK), please refer to all the reference documents stated in section 3.1

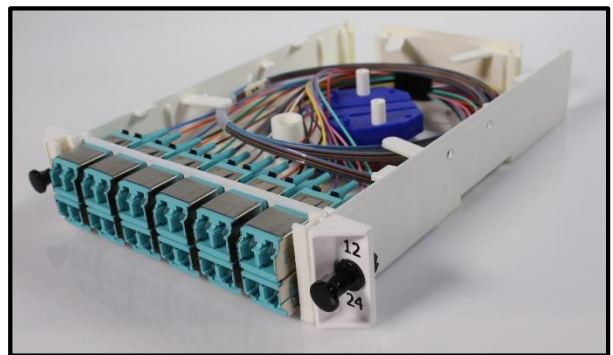

Figure 1

New FOX Cassette that holds two(2)-12 fiber ribbons

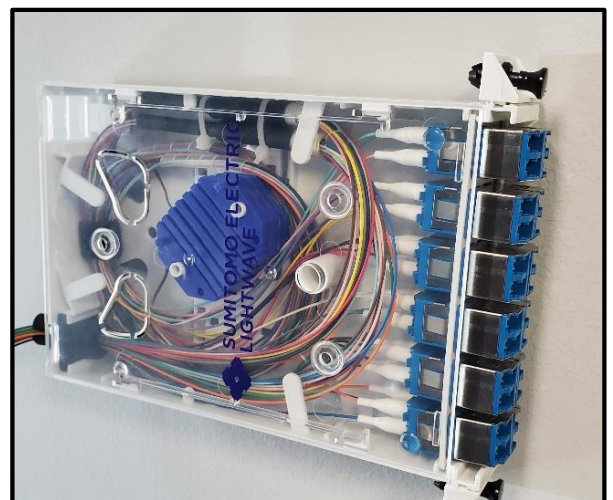

Figure 2

FOX Cassette that holds 24 individual tight buffer fiber splices

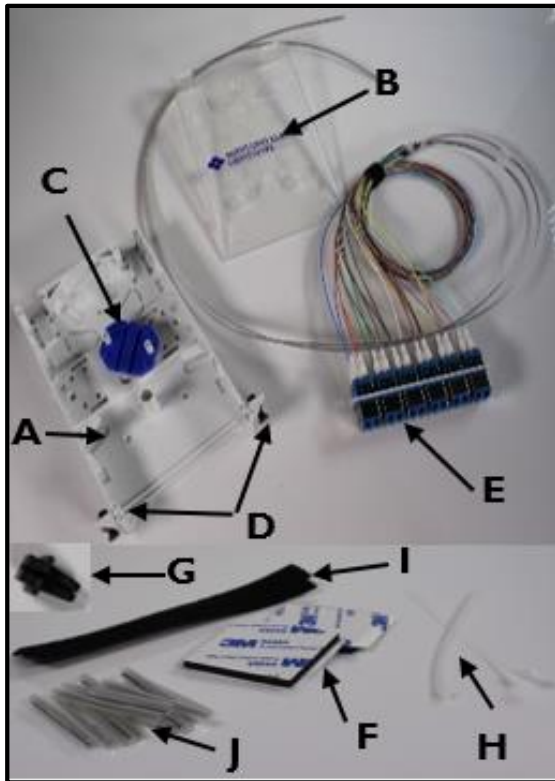

Figure 3
FOX Cassette Components

5.2 Figure 3 displays a 24 capacity FOX cassette with two ribbon terminations. This instruction sheet addresses both 900 μm breakout and terminations. Below is everything included with FOX cassette purchase.

- A. Cassette -The main housing that contains the interconnect panel and the fiber breakout.
- B. Cover/Lid – The cover requires no tools to remove. See **Figure 4**.
- C. Splice Tray Shuttle – Inside the cassette. Can be removed by sliding up white pipes attached to the case to accommodate splicing outside the cassette. Either 1 is provided that can hold two ribbon splices or four provided to house 24 individual splices.
- D. Removable Ears- Can be easily removed and replaced for installation and rework convenience.

E. Faceplate- Adapter location that can be removed for easier connectorization and cable management.

F. Double Sided Foam Tape – Along with zip ties is used to secure the Central Tube into the cable entry.

G. Cable Grommet – Used as a securing point when fiber is inside a sock or ABF tube.

H. Zip Ties – Used to secure the cable and/or Cable Grommet into the entry points.

I. Hook and Loop Velcro Fastener – Maintains organization inside cassette.

J. Splice Protection Sleeve – Steel reinforced heat shrink sleeve.

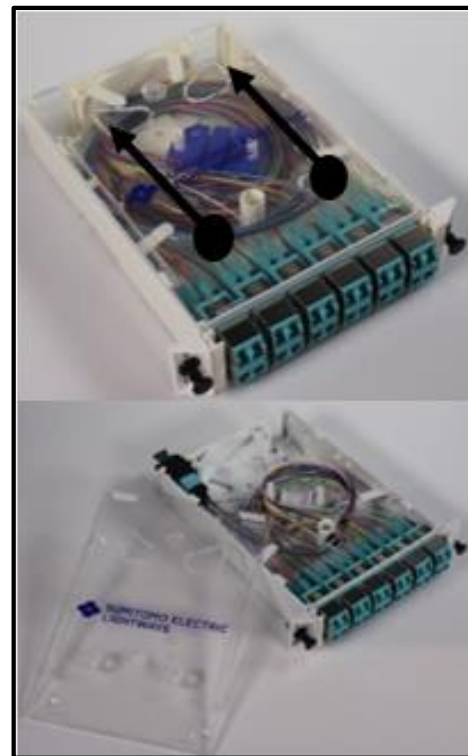

Figure 4
Firmly press thumbs down where black dots are on clear lid and slide lid towards back of cassette (away from faceplate).

5.3 Each Fox Cassette faceplate is easily removed in two steps. See Figure 5.

5.3.1 With lid removed, use thumbs to apply pressure on inside of cassette near faceplate and push towards the outside to expose faceplate extrusions.

5.3.2 Faceplate extrusions (circled below) will be exposed and can be lifted out of track.

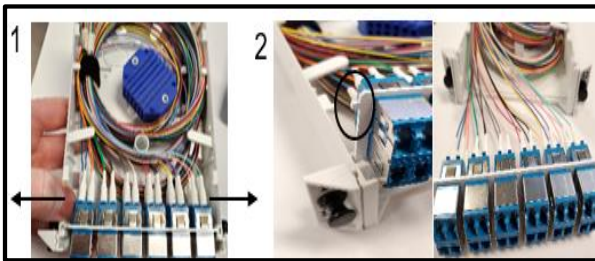

Figure 5

Faceplate removal procedure.

5.4 Predetermined knockouts can be popped out in the lid and bottom of cassette to route fibers into parallel cassettes and stack. See Figure 6



Figure 6

Lid (Left) and Bottom of cassette (Right) knockouts.

6.0 Installation for 12 and 24 Fiber Ribbon FOX Cassettes

Regardless of the type of Cassette used for Ribbon, follow the pattern seen in Table 1 or Table 2 as appropriate when running and splicing to the cassette splice tray or into the back of the FOX cassette that has an MPO connector.

NOTE: Ribbon Furcation tube breakout kits must be used with Ribbon Cassettes.

| Grp# | Group Color | (24)-Strand FOX Cassette |
|------|------------------------|--------------------------|
| 1 | Blue = Strands 1-12 | 1st Cassette |
| 2 | Orange = Strands 13-24 | |
| 3 | Green = Strands 25-36 | 2nd Cassette |
| 4 | Brown = Strands 37-48 | |
| 5 | Slate = Strands 49-60 | 3rd Cassette |
| 6 | White = Strands 61-72 | |

Table 1

Pattern for 24 Ribbon Fox Cassette. Blue will be spliced to the first 12 fibers (unit one) of the FOX cassette and orange will be spliced to the 2nd unit fibers. See Figure 9.



| Grp# | Group Color | (12)-Strand FOX Cassette |
|------|------------------------|--------------------------|
| 1 | Blue = Strands 1-12 | 1st Cassette |
| 2 | Orange = Strands 13-24 | 2nd Cassette |
| 3 | Green = Strands 25-36 | 3rd Cassette |
| 4 | Brown = Strands 37-48 | 4th Cassette |
| 5 | Slate = Strands 49-60 | 5th Cassette |
| 6 | White = Strands 61-72 | 6th Cassette |

Table 2

Pattern for 12 Ribbon Fox Cassette termination

6.1 Strip at least 3 feet of fiber bundle (Follow SRP SP-F04-045 and for more details on this process).

6.2 Similar to Roman Numerals, fiber bundle ribbons are labeled using 1 bar for the 1st ribbon, 2 bars for the 2nd ribbon, etc. *(The bars may follow a long block "visibility block" for easier visual identification.)*

| 12-Fiber – Ribbon Marking Pattern | | | |
|-----------------------------------|---|---|---|
| Number / Value | 1 | 5 | Visibility Block |
| Symbol |  |  |  |
| | Bar | Short Block | Long Block |

Manufacturers use 1 of 2 ribbon marking methods: (M1 or M2 as defined in the Table below)

| | Ribbon 1 | Ribbon 2 | Ribbon 3 | Ribbon 4 | Ribbon 5 | Ribbon 6 |
|----|----------|----------|----------|----------|----------|----------|
| M1 | I | II | III | IIII | ■ | ■I |
| M2 | ■I | ■II | ■III | ■IIII | ■■ | ■■I |

6.3 Insert each ribbon into the correct furcation tubing starting with 1 into the blue labeled tubing. See **Fig 7**. Keep in mind the installation will be similar for all cassette types.

6.3.1 Slide the entire length of the furcation tube over the ribbon grouping until it exits the other end (which will be used for termination).

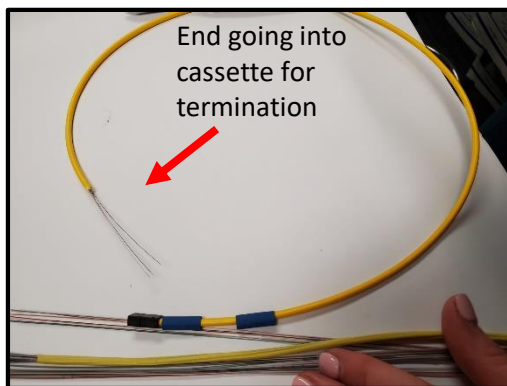

Figure 7

First ribbon inserted into the blue furcation tube.

6.4 Place the black furcation tubing piece into the breakout unit kit housing. SRP F04-046 talks about specific placement in housing, but as long as the colored tubing or number labels are on, this housing placement is not critical. See Figure 8 for setup from stripped bundle inserted into a breakout kit housing leading into the ribbon bundle encased in a furcation tube, and finally MPO termination.

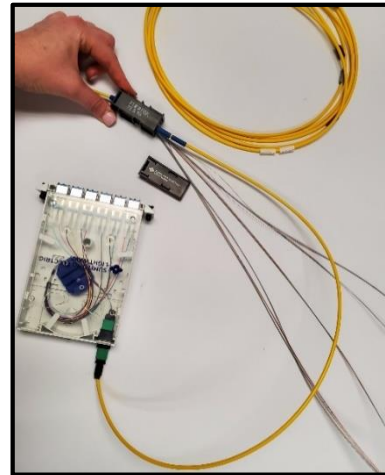

Figure 8

The furcation tube encasing a ribbon was inserted into the breakout kit housing followed by termination to an MPO connector for connectivity to an MPO FOX Cassette.

6.5 If you are terminating into a ribbon FOX cassette without an MPO connector, you will run the ribbons into the back of the cassette. Once two ribbons have been ran into the cassette, splice the ends to the breakout unit ribbon to one of the ribbon termination units in the cassette. Make sure to splice the first ribbon to unit 1 and second ribbon to unit 2. See **Figure 9 and Table 1/2**. Ensure that the cables going into the cassette are curled in the opposite direction to the cables in the cassette.

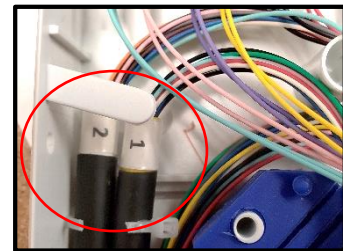

Figure 9

Cut zip tie to reveal Unit 1 and 2 (containing 12 fibers each) of the 24 fiber FOX cassette. 12 fiber FOX Cassettes only have one unit.

6.5.1 For 12 fiber ribbon cassettes each furcation tube will have a single ribbon and are terminated to the only unit of 12 fibers included in the FOX cassette.

6.6 Place protected splice into splice sleeve module. Use zip ties and Velcro for cable organization around inside of cassette. Then, use grommet to hold furcation tubes entering into FOX cassette lid (see **Fig 10**)

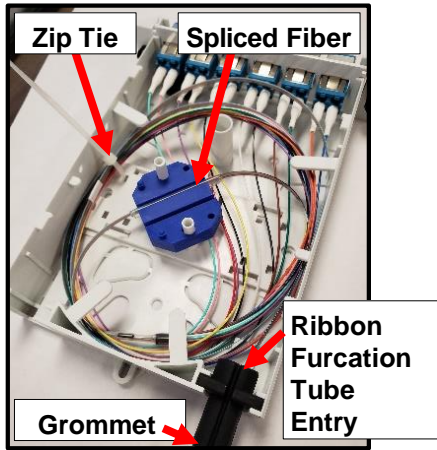

Figure 10

Ribbon Splice in module, fibers organized with zip ties, and grommet placed in back of cassette routing out the ribbon furcation tubes.

6.7. After grommet is placed around incoming furcation tubes. Place FOX lid back on. Repeat until all ribbons are terminated.

7.0 Installation for 12 and 24 fiber tight buffer FOX Cassettes

When using a 12 fiber or 24 fiber fox cassette, follow the Tables 3 and 4 for organizing color patterns.

NOTE: For Table 3 below, the blue subunit will be spliced to the first unit of 12 fiber ribbons in cassette and orange in unit 2 as shown in Figure 9.

| Grp# | Group Color | (24)-Strand FOX Cassette |
|------|------------------------|--------------------------|
| 1 | Blue = Strands 1-12 | 1st Cassette |
| 2 | Orange = Strands 13-24 | |
| 3 | Green = Strands 25-36 | 2nd Cassette |
| 4 | Brown = Strands 37-48 | |
| 5 | Slate = Strands 49-60 | 3rd Cassette |
| 6 | White = Strands 61-72 | |

Table 3

Pattern for 24 Fiber FOX Cassette

| Grp# | Group Color | (12)-Strand FOX Cassette |
|------|------------------------|--------------------------|
| 1 | Blue = Strands 1-12 | 1st Cassette |
| 2 | Orange = Strands 13-24 | 2nd Cassette |
| 3 | Green = Strands 25-36 | 3rd Cassette |
| 4 | Brown = Strands 37-48 | 4th Cassette |
| 5 | Slate = Strands 49-60 | 5th Cassette |
| 6 | White = Strands 61-72 | 6th Cassette |

Table 4

Pattern for 12 Fiber Fox Cassette

7.1 An example of the first fox cassette is shown in Figure 11. Remember each cassette installation will remain the same process wise. Start by stripping 3 feet of your fiber bundle and identify each individual fiber.

7.1.1 The PVDF Fiber bundles are only available as ribbons, so in order to use tight buffer cassettes the fiber bundle's matrix must be removed. Follow SRP SP-F04-050 to remove the matrix. Following matrix removal, they must be inserted into tight buffer breakout kits (SRP SP-F04-47). Only then can you proceed into tight buffer cassettes.

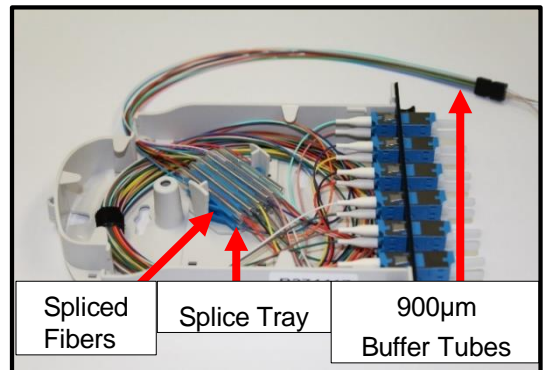

Figure 11

12 Fiber Fox Cassette with 900µm Furcation Tube. There are only 2 blue splice modules to hold the 12 fiber splices required. Four would be provided for 24 capacity cassettes.

7.2 Once each 900µm furcation tube has been labeled with a color marker tube, run single fibers into the correct color tubing housing and finally route them into the back of the cassette.

NOTE: The installation of the FP48PVS follows the same procedures as the FP72PVx series of fiber bundles.

7.3 Splice the ends of the 900µm coming into the cassette to the ends already in the fibers in the cassettes color coated for termination. Refer to Figure 13 and Table 3/4. The Blue fiber on the blue subunit of the 1st ribbon will be spliced to the 1st blue fiber termination unit in the FOX cassette. Continue to splice the rest of the first 12 fibers to Cassette unit 1's fiber ends.

7.4 Proceed with the second fiber ribbon unit (orange) and splice blue fiber of second ribbon to the 2nd unit of FOX's cassette's blue fiber (or into 2nd cassette for 12 capacity cassettes). Proceed until all splices are done and place protected splice sleeves in splice tray modules.

7.5 Use Velcro and zip ties to organize fibers within cassette.

7.6 Use grommet to support breakout single fiber furcation tube entry in back of cassette and close lid.

7.7 Repeat as needed for each FOX cassette.



Figure 12

Fibers organized in FOX cassette, grommet placed for cable entry in back, and lid closed.



12 single fiber buffer tubes spliced to unit one of the FOX cassette. 12 more buffer tubes are spliced to unit 2 of the FOX cassette.

Figure 13

24 tight buffer fiber tubes from tight buffer breakout kit terminated in a 24 capacity tight buffer FOX cassette.