

**SUMITOMO RECOMMENDED PROCEDURE****SRP SP-F04-005****INDOOR WALL-MOUNT TDU INSTALLATION PROCEDURE**

<b><u>PARA.</u></b>	<b><u>CONTENTS</u></b>
1.0 2.0 3.0 4.0 5.0	General Safety Precautions Reference Documents Equipment / Tools Required Equipment Layout
6.0 7.0 8.0 9.0	Mounting the Tube Distribution Unit Preparing the Tube Distribution Unit Preparing Tube Cables for Coupling Making Tube Interconnections
10.0	Tandem-Mount TDU & FTU Installation

SUMITOMO ELECTRIC LIGHTWAVE CORP.  
201 South Rogers Lane, Suite 100, Raleigh, NC 27610  
(919) 541-8100 or 1-800-358-7378

[www.sumitomoelectriclightwave.com](http://www.sumitomoelectriclightwave.com)

SEL is a Member of the Sumitomo Electric Industries, Ltd. Group  
*Sumitomo Electric Lightwave reserves the right to improve or modify these specifications without notice.*

## 1.0 General

1.1 This procedure describes the standard techniques for installing a FutureFLEX Air-Blown Fiber (ABF) indoor, wall-mounted Tube Distribution Unit (TDU).

1.2 The TDU (DE06MDU) is typically used at any indoor location where up to 42 tubes total require interconnection (e.g.: building entrances, riser shafts, etc.).

**Note:** TDU capacity of up to 42 tubes could equal six (6) 7-tube cables entering TDU and six (6) 7-tube cables exiting TDU, or two (2) 19-tube cables entering TDU and two (2) 19-tube cables exiting TDU, or any combination thereof.

1.3 This procedure also describes the standard techniques for tandem-mounting Fiber Termination Unit (FTU) FT24WFM or FT48WFM to a wall-mounted TDU (DE06MDU) to create a modular installation.

1.3 Two (2) personnel are recommended to accomplish this procedure.

## 2.0 Safety Precautions

2.1 The use of personal safety equipment (safety glasses, safety shoes, cut-resistant Kevlar gloves, etc.) is recommended during this installation procedure.

## 3.0 Reference Documents

3.1 Sumitomo Recommended Procedure, *FutureFLEX Tube Cable Installation Procedures*, SRP SP-F04-008.

3.2 Sumitomo Recommended Procedure, *FutureFLEX Grounding & Bonding Metallic Tube Cables*, SRP SP-F04-030.

## 4.0 Equipment / Tools Required

The following equipment, tools, and materials are required to complete this procedure.

4.1 Indoor, wall-mounted Tube Distribution Unit (DE06MDU):

- Aluminum construction
- 16" H x 16" W x 4" D
- 5 lbs. approximate

- DE06MDU Kit contents include hose clamps, knockout bushings, grommet edging, and four (4) Tube Clip Organizers (DETC008) pre-fastened to inside of enclosure.

4.2 Wood Screws or Anchor Bolts, 1/4" thread diameter recommended.

4.3 Drill Motor and Drill Bits

4.4 Surface Level

4.5 Hammer

4.6 Punch

4.7 Screwdrivers

4.8 1-7/8"-to-2" diameter Hole Punch (necessary only if terminating 19-tube cables)

4.9 Hook Blade Knife

4.10 Tube Cable Cutter (BETL001)

4.11 Tubing Cutter (BETC001)

4.12 Tube Couplings (DE08MC2)

4.13 Tube Plugs (DE06MP)

## 5.0 Equipment Layout

5.1 See Fig. 1 for TDU layout.



**Figure 1**  
Indoor, Wall-Mounted TDU (DE06MDU)

## 6.0 Mounting the Tube Distribution Unit

6.1 Before mounting TDU, consider the following.

6.1.1 Chose wall mounting location to allow for as many tube cables as possible to enter TDU.

6.1.2 Compare tube cable room entrance locations to TDU knockout locations and optimize TDU mounting location based on minimal cable bending.

6.1.3 Chose wall mounting location to provide enough space for best routing / mounting of tube cables into and out of TDU.

6.1.4 Consider each tube cable's minimum bend radius (during installation 20X tube cable OD and after installation 10X tube cable OD) and verify adequate wall space exists.

6.1.5 Verify wall mounting surface is constructed of materials which will allow screws or anchor bolts to be used for mounting and will adequately support the weight of the TDU.

6.2 To mount TDU, position on wall and use a surface level to determine level and plum. Have one person hold leveled TDU against the wall while another marks the four (4) screw / bolt locations through TDU mounting holes.

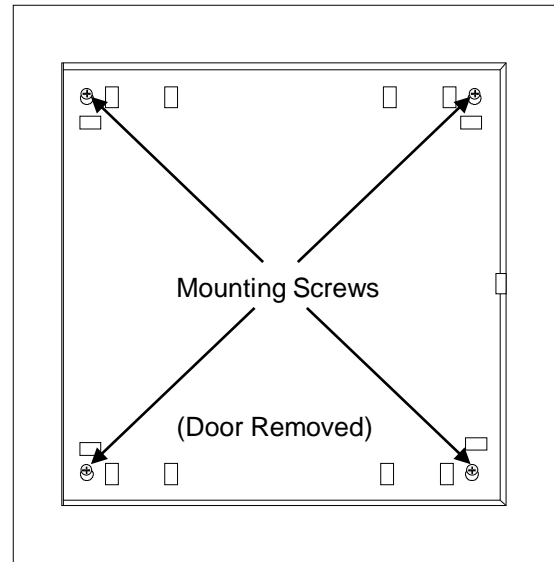
6.3 Remove TDU and use drill motor with correct size drill bit for mounting hardware chosen to drill holes into wall at marked locations.

6.4 Attach mounting screw / bolt retainers (if used) to the wall per manufacturer's instructions.

6.5 Thread one screw / bolt a few turns into each hole but do not tighten.

6.6 Install TDU onto wall by guiding screw heads through lower portion of each mounting hole.

6.7 Use surface level on top and side of TDU to verify final alignment and tighten four (4) mounting screws. **See Fig. 2.**

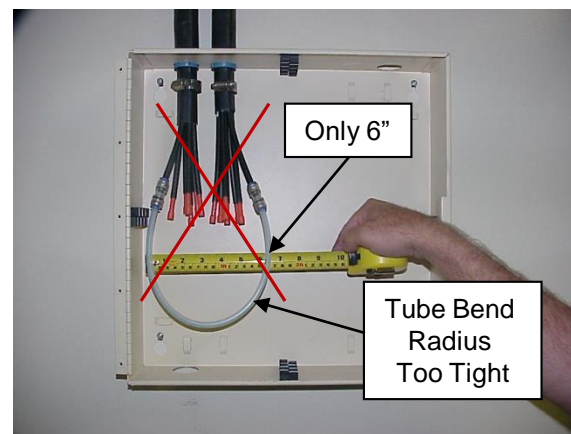


**Figure 2**  
TDU Mounting Screw Locations

## 7.0 Preparing the Tube Distribution Unit

7.1 Choose knockout positions on TDU that best suit desired cable entry / exit locations.

7.2 Where possible, do not locate tube cables side-by-side. When tubes are interconnected, tight tube bending inside TDU will result that could damage individual tubes. Additionally, fiber bundle installation operations will be very difficult. **See Fig. 3.**



**Figure 3**  
Locating Tube Cables Side-By-Side  
Creates Tight Tube Bends and  
Difficult Fiber Bundle Installation

**CAUTION:** Knockout hole edges are sharp. Wear gloves to prevent injury.

7.3 For small diameter 2- to 7-tube cables, use hammer and punch to remove TDU knockouts.

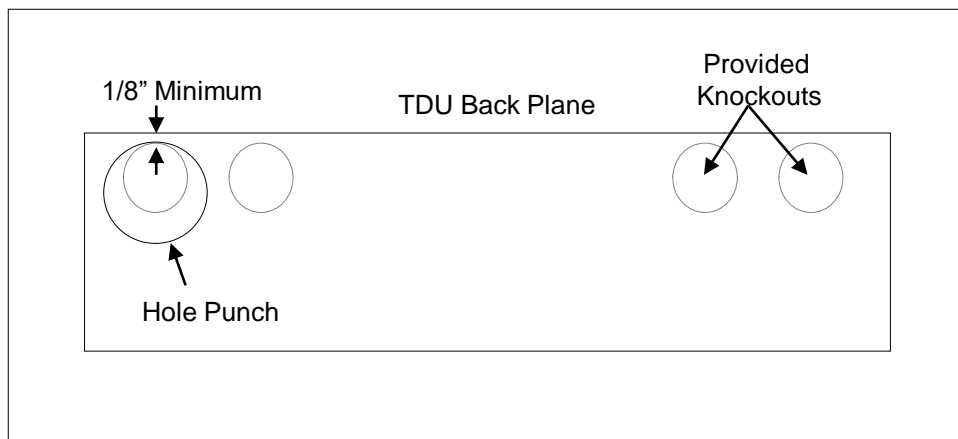
7.4 Install plastic knockout bushing (included with TDU) into each open knockout hole. Push bushing into hole from outside TDU until it pops into place.

7.5 For large diameter 19-tube cables, the existing TDU knockouts are too small. Use a

1-7/8" to 2" diameter hole punch to create an opening large enough for cable entry.

7.6 When using hole punch, do not remove TDU knockout. Position hole punch so its edge is about 1/8" minimum from TDU back plane. **See Fig. 4.**

**Note:** If hole punch is used, install grommet edging (included with TDU) into hole to eliminate sharp edges.



**Figure 4**  
Hole Punch Location for Larger Diameter 19-Tube Cables

## 8.0 Preparing Tube Cables for Coupling

8.1 To prepare tube cables for coupling inside TDU area, perform the following steps.

8.2 Route tube cable into TDU and mark outer jacket to leave about 1"-2" of jacket length inside TDU. **See Fig. 5.**

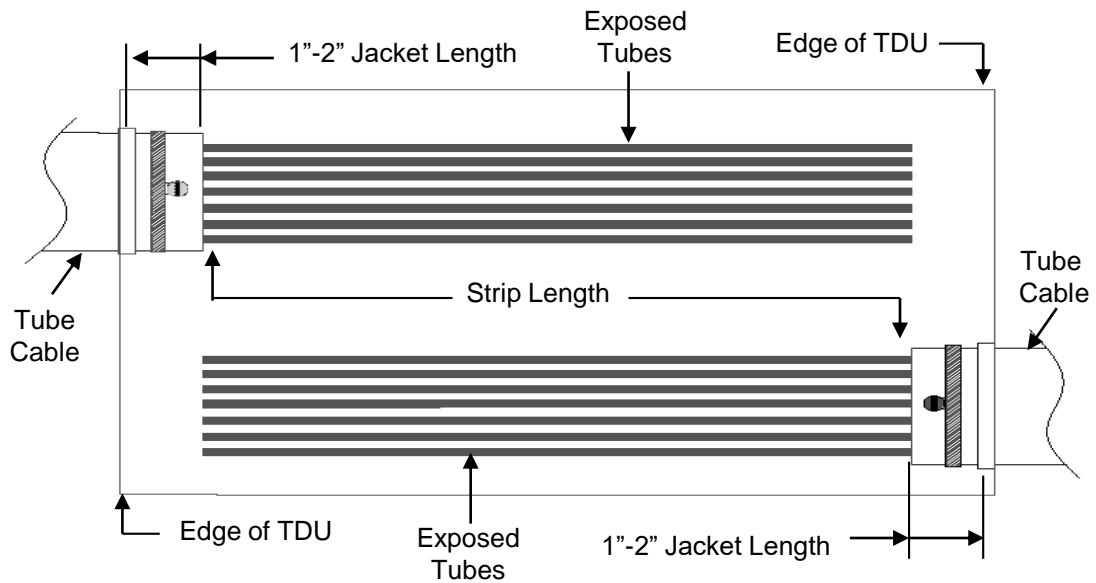
8.3 Measure to other side of TDU to determine available strip length and mark outer jacket.

8.4 Remove tube cable from TDU and use Tube Cable Cutter (BETL001) to cut tube cable to length.

8.5 Use Hook Blade Knife to lightly score outer jacket at 1"-2" mark. Pull ripcord and strip jacket away to expose tubes.

**Note:** If tube cable being prepared is an older 7-tube double-jacketed TC07TRX Riser-rated design, the outermost jacket is too large to fit through the standard knockout opening provided in TDU (DE06MDU). Remove the outer jacket so it stops / ends outside the TDU. The inner jacket will pass through the TDU knockout opening. The newer single-jacketed TC07TRC Riser-rated design will fit through the standard knockout without modification.

8.6 Route each prepared tube cable through its designated knockout opening.



**Figure 5**  
Preparing Tube Cables for TDU Installation

8.7 Use hose clamp (included with TDU) to secure tube cable to inside, back surface of TDU.

8.7.1 Undo and thread hose clamp through hose clamp mounting tab located next to knockout opening.

8.7.2 Carefully tighten hose clamp around tube cable jacket; do not over-tighten or tube cable damage can result. **See Fig. 6.**

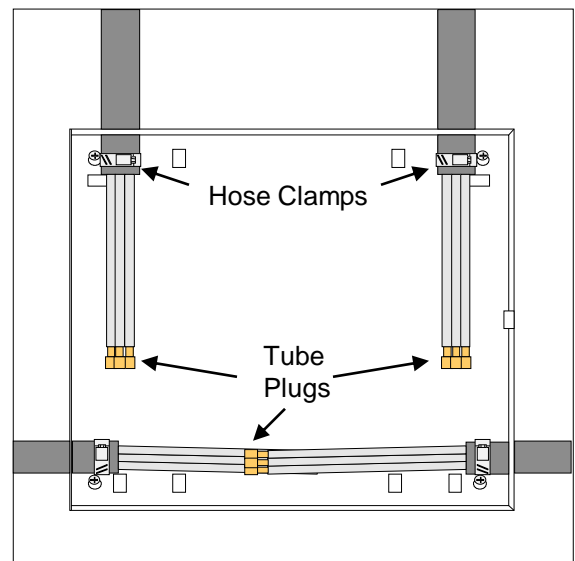
8.8 If installing a metallic tube cable, install appropriate grounding hardware. See SRP SP-F04-030.

8.9 Use Tubing Cutter (BETC001) to trim ends of tubes.

8.10 Use Tube Plugs (DE06MP) to seal open tube ends.

## 9.0 Making Tube Interconnections

9.1 When fiber bundle routes are established, a schedule of tube interconnections should be generated. Use the schedule to determine the required tube interconnections at each TDU location.



**Figure 6**  
Initial Installation of Tube Cables in TDU

9.2 Locate tubes inside TDU that are to be connected according to tube interconnection schedule and remove Tube Plugs (DE06MP).

9.3 Tube interconnections can be straight through, cross-connected, or loop (180-degree turns).

#### 9.4 Straight Through Interconnections

Straight through interconnections are preferred as they present the least resistance and drag during fiber bundle installation operations.

9.4.1 Determine if tubes to be coupled are long enough to be connected straight through. If so, overlap tubes, position Tube Coupling (DE08MC2) in desired location, and mark tubes at center point of Tube Coupling.

9.4.2 Use Tubing Cutter (BETC001) to cut tube ends at mark and install Tube Coupling. Be sure each tube is pushed all the way into its coupling and fully and firmly seated. **See Fig. 7.**

**Note:** Always cut tube ends long, test fit Tube Coupling, and, if tubes are too long, re-trim until a good fit is obtained.

9.4.3 If tubes ends are too short to overlap, custom cut a short piece of jumper tubing to fit. Install jumper tubing with two (2) Tube Couplings. Jumper tube length should be just long enough to fill the void between the two tube ends.

#### 9.5 Cross-Connect Interconnections

Try to avoid cross-connections because they introduce S-curves into a tube route. S-curves present a high resistance and drag during fiber bundle installation operations.

9.5.1 If tubes to be coupled are long enough, overlap tubes, position Tube Coupling in desired location, and mark tubes at center point of Tube Coupling.

9.5.2 Use Tubing Cutter to cut tube ends at mark and install Tube Coupling. Be sure each tube is pushed all the way into its coupling and fully and firmly seated.

9.5.3 If tubes ends are too short to overlap, custom cut a short piece of jumper tubing to fit. Install jumper tubing with two (2) Tube Couplings. Jumper tube length should be just long enough to fill the void between the two tube ends.

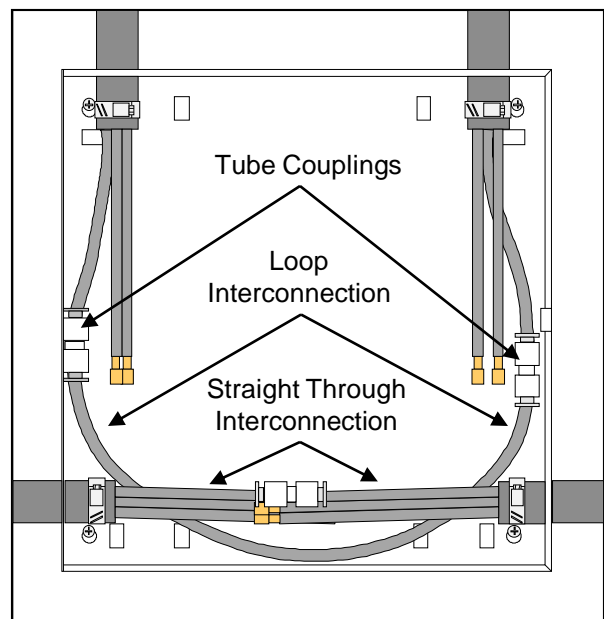
#### 9.6 Loop Interconnections

Loop interconnections (180-degree turns) are the least desirable type of tube interconnection. They present the most resistance and drag during fiber bundle installation operations.

9.6.1 **Important Point.** If two tubes must be connected in a loop interconnection, do not couple them with one Tube Coupling. Locating Tube Couplings in tight bends / curves can cause the front end of a fiber bundle to hang up in the coupling during blowing operations. Always install Tube Couplings in straight sections of tubing. **Refer to Fig. 7.**

9.6.2 Use Tubing Cutter to cut tubes so a Tube Coupling can be connected to each tube end in a straight section of tube route.

9.6.3 Custom cut a piece of jumper tubing that will allow the two tube ends to be connected with as smooth and as large a radius as possible within the TDU.



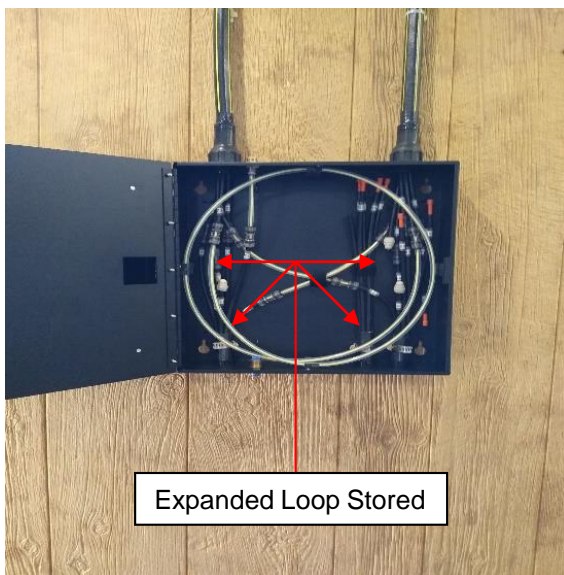
**Figure 7**  
Straight Through and Loop Tube  
Interconnections  
(Tube Couplings in Straight Tube Sections)



### 9.7 Expanded Loop Technique

If fiber bundle blowing performance might be an issue because of tight tube bends inside a TDU, install a larger loop interconnection. The “expanded loop” presents significantly less resistance and drag during fiber bundle installation operations.

9.7.1 Custom cut a long piece of jumper tubing to fit between the two tube ends.



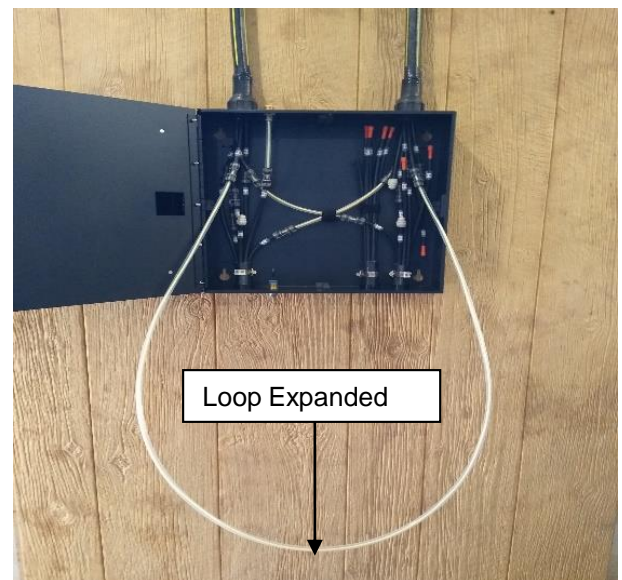
**Figure 8a**

Long Jumper Tubing Section Stored Inside TDU  
(Before and After Blowing Operations)

9.7.2 **Key Step.** Coil and test fit jumper tubing until it can be satisfactorily and neatly stored inside the TDU. **See Fig. 8a.**

9.7.2 When ready to begin blowing operations, open TDU, uncoil, and expand jumper tubing into its much larger radius loop. **See Fig. 8b.**

9.7.3 After blowing operations are completed, carefully coil and return jumper tubing to its stored position inside TDU.



**Figure 8b**

Long Jumper Tubing Expanded for  
Better Fiber Bundle Blowing Operations

## 10.0 Tandem-Mount TDU & FTU Installation

10.1 If wall space is limited within an electronics room (e.g.: MDF or IDF) where fiber bundles will be terminated, a Tandem-Mount TDU & FTU arrangement offers a space-saving solution. **See Fig. 9.**



**Figure 9**

Tandem-Mount TDU & FTU Installation

### 10.1.1 Tandem-Mount - (Supporting Documents)

Refer SEL Drawings :

**SD-F04-090** - FTWM-08L and  
FTWM-TANDEM-DOOR

**SD-F04-093** - FTWM-TANDEM-DOOR

**SD-F04-100** - DE06MDU

The above Documents provide Product Specific detail for each of these 3 Products and, when combined and assembled create a Single Wall Mountable Enclosure capable of being both a hub for Fiber Distribution while also housing Fiber Terminations. Please request the above documents to review the following details:

- Dimensional Specifications
- Construction Detail
- Kitting Specific Detail
- Compatible SEL Accessories

10.2 The Wall-mounted assembly requires the following part numbers:

- DE06MDU, TDU 16" H x 16" W x 4" D
- FTWM08L, FTU 13" H x 14.5" W x 6" D
- FTWM-TANDEM-DOOR 16 x 15.75

10.3 **Important.** Before installing TDU and FTU, verify sufficient clearance area exists to accommodate the wider door swing.

See Fig. 10.



**Figure 10**

Tandem-Mount TDU & FTU (FTU open)

10.4 To accomplish a Tandem-Mount TDU & FTU installation, perform the following steps.  
**See Fig. 11. a,b,c,d**

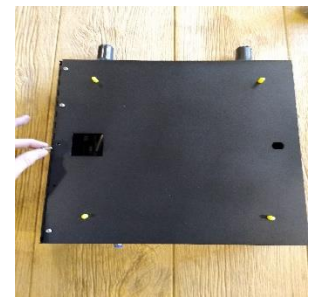
10.4 Wall-mount TDU (DE06MDU) per this procedure. After TDU is installed, use an adjustable wrench to remove TDU key lock assembly from its door and retain.

10.5 Remove five (5) hinge screws from TDU door and retain. Place TDU door aside.

10.6 Use the five (5) door screws to install FTWM-TANDEMDOOR panel to DE06MDU TDU hinge.

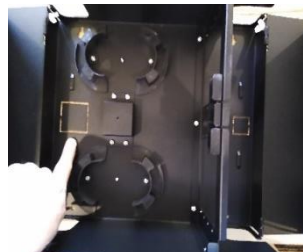


**Figure 11a.**



**Figure 11b.**

10.7 FTWM08L comes with two square knockouts in the back plane. Use hammer and punch to remove knockout and file edges.



**Figure 11c.**



**Figure 11d.**

Re-install TDU key lock assembly removed earlier to FTU. This feature holds / locks the FTU to the TDU. Then remove yellow screw covers. Mount FTU to FTWM-TANDEM-DOOR panel use four (4) nuts supplied and secure.



10.8 Install grommet edging (included with TDU) into knockout to eliminate sharp edges. This features allows the passage of tubing such as reducing tube (TC01T6M) and the reducing coupler (DE06RC) from the TDU area to the FTU area.

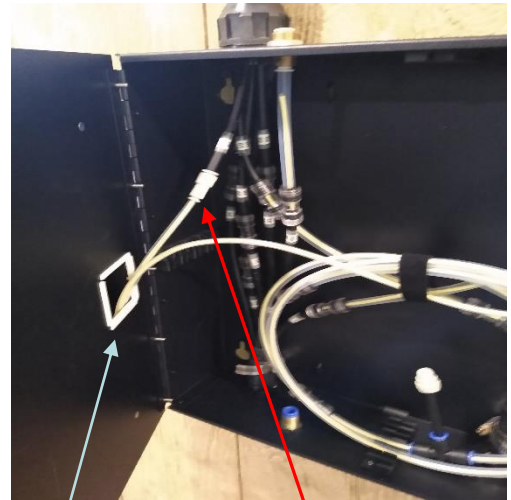
**See Fig 12**

10.9 Check installation by making sure FTU swings (opens and closes) easily and that key lock assembly secures FTU to TDU properly. Fiber Bundle rough in / placement complete.

**See Fig 13**

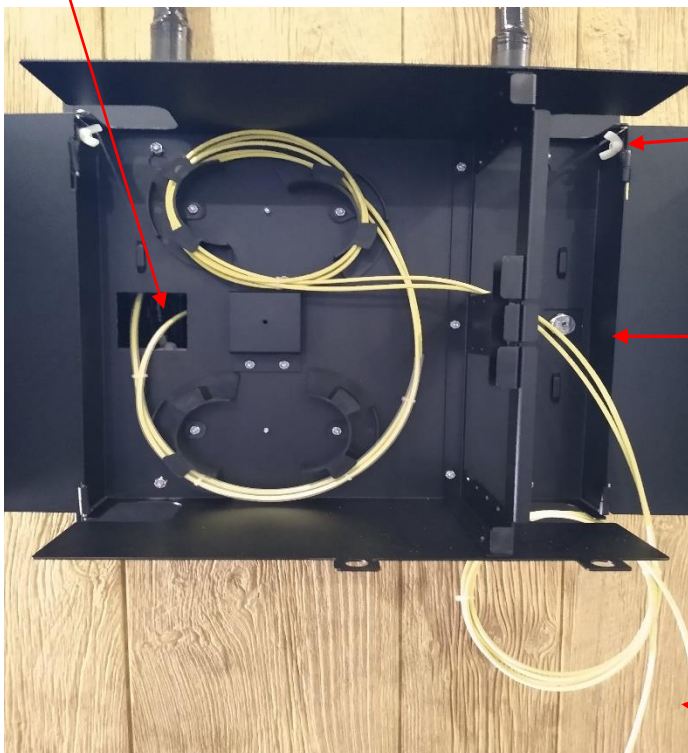
**Note:**

Refer to SRP's - SP-04-006 for Fiber Bundle Striping Procedure and SP-04-036 Field Terminations kits



**Figure 12**  
Grommet  
DE06RC  
Reducing Coupler & TC06T6M  
Reducing Tube

Knockout for  
Tube Passage



Door Hinge Stop

Key Lock Assembly

Fiber Bundle Slack Footage  
approx. 6 ft. For Termination

**Figure 13**