

SUMITOMO RECOMMENDED PROCEDURE**SRP SP-F05-033****PrecisionFlex™ MPO Cassette Panel Installation**

<u>PARA.</u>	<u>CONTENTS</u>
1.0	General
2.0	Safety Precautions
3.0	Other Precautions
4.0	Product Parts
5.0	MPO Cassette Module Mounting Method
6.0	How to Insert MPO Connector
7.0	How To Change Bracket Position

SUMITOMO ELECTRIC LIGHTWAVE CORP.
201 South Rogers Lane, Suite 100, Raleigh, NC 27610
(919) 541-8100 or 1-800-358-7378
www.sumitomoelectriclightwave.com

SEL is a Member of the Sumitomo Electric Industries, Ltd. Group
Sumitomo Electric Lightwave reserves the right to improve or modify these specifications without notice.

1.0 General

1.1 Please read this manual carefully and understand the contents before use. This procedure describes the standard installation procedure for Sumitomo's PrecisionFlex MPO Cassette Panel.

2.0 Safety Precautions

2.1 The use of personal safety equipment (safety glasses, cut-resistant Kevlar gloves, etc.) is recommended during this installation procedure.

2.2 Do not place in an unstable place · Firmly clamp the panel to prevent it from falling

2.3 Do not drop any parts or tools

2.4 Pay attention to slide structure. Be careful not to pinch your fingers or hands when opening and closing the slide chassis.

2.5 Pay attention to sharp parts. Take great care when using knives and other sharp objects and tools

3.0 Other Precautions

3.1 When assembling the slide panel ,do not use parts other than those intended for the product.

3.2 When working with a specified tightening torque, follow the regulations. It may cause functional degradation or damage to this product.

3.3 Do not place anything on the product or lean against it.

3.4 Do not place objects on the slide chassis when the slide chassis is pulled out.

3.5 Ensure allowable bending radius of wiring. Observe the allowable bending radius for optical fiber wiring.

3.6 Clean the connector end face before connecting. Clean the connector and the end face of the built-in connector before use.

4.0 Product Parts (Example of slide chassis)

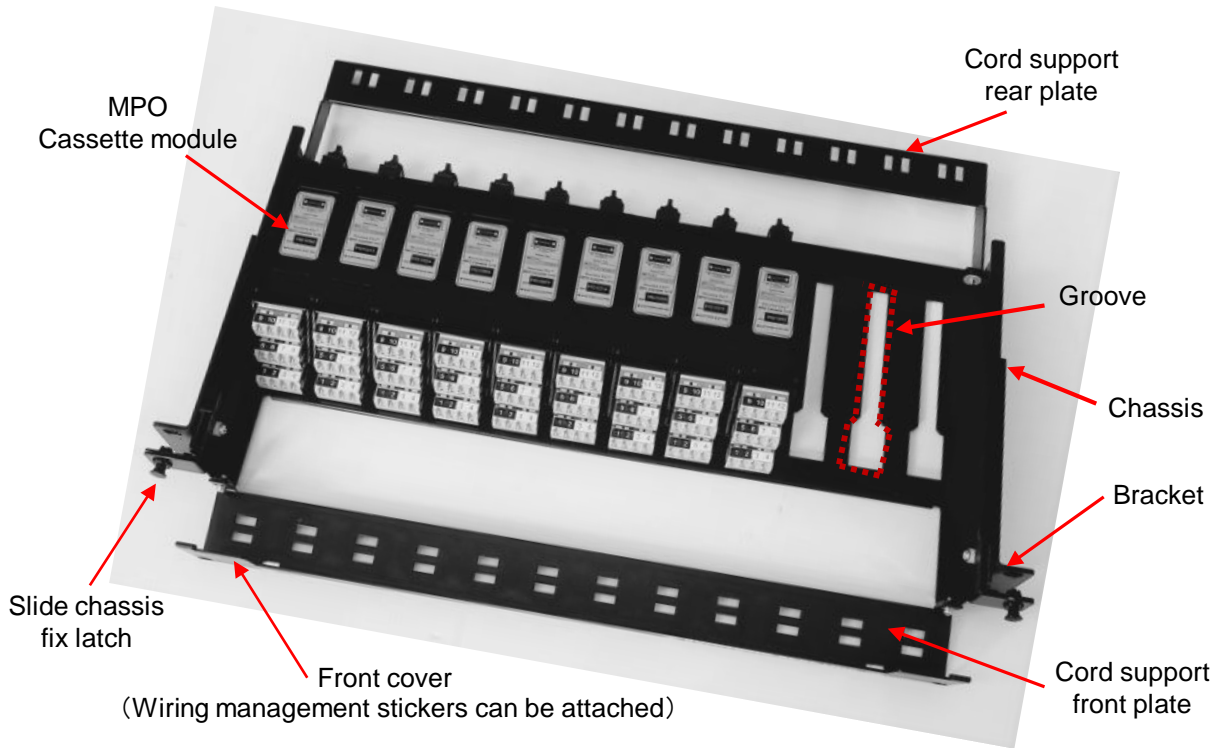

SM(OS1, OS2 compliant)
MPO Cassette module



MM(OM3, OM4 compliant)
MPO Cassette module

5.0 MPO Cassette Module Mounting Method

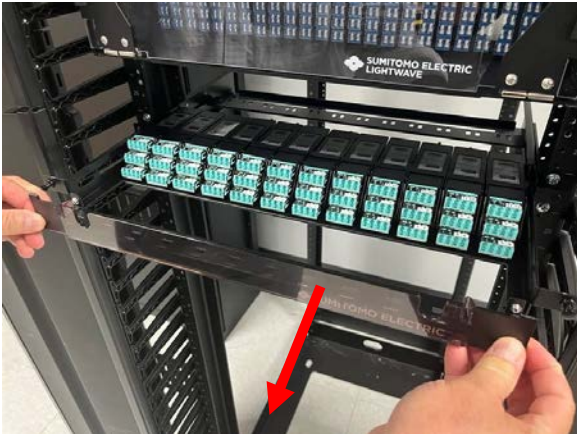

5.1 Hold both the left and right latch (black color) and pull the slide chassis to the front.

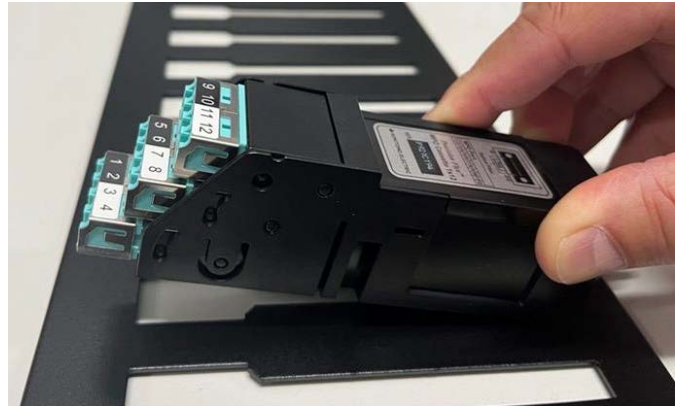

5.2 Insert the cassette from the back of the slide chassis groove.



5.3 Insert the entire cassette.



Click !

Lock !

5.4 Insert the cassette bottom clip on the front .
Slide until you hear the sound.

5.5 Slide tab forward until it
clicks to lock in places.

*If you are using the fixed chassis (PFCST-1U-F12-BK),
please refer to 5.2 to 5.5.

5.0 MPO Cassette module mounting method - continued

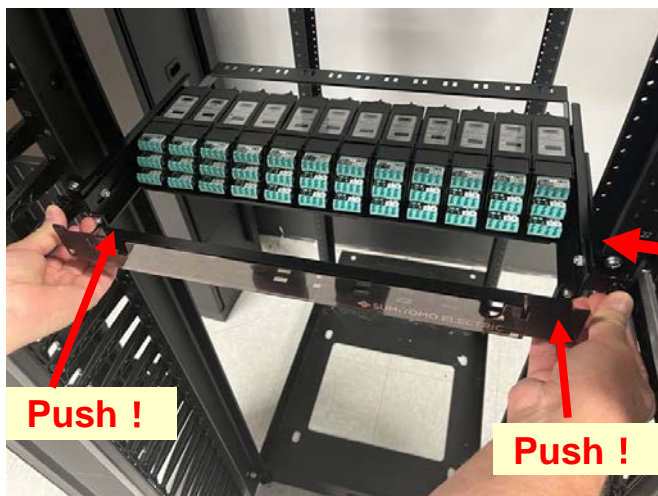

5.6 Return the slide chassis to the original position and push in the left and right latch to secure them.

6.0 How to insert MPO Connector (Cassette rear adapter)

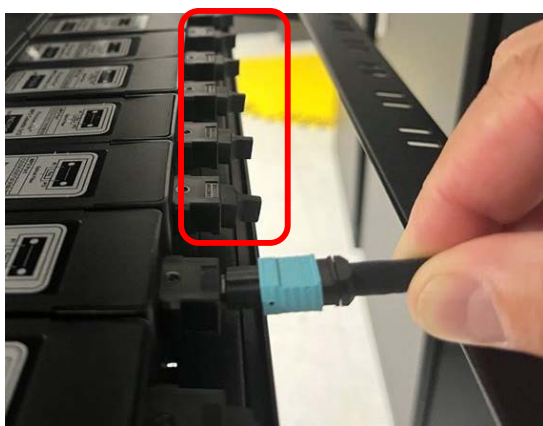

6.1 Please keep MPO connector end cap on until inserting MPO connector.

6.2 In case loss value is not normal, you may need to clean the connector end with connector cleaner. In that case, loosen the left and right screws securing the cord support rear plate and tilt the plate downward.







6.3 Clean the internal MPO connector end face by using commercially available connector cleaner.

After cleaning, put the cord support rear plate back in place and secure it with the screws. Recommended tightening torque is $0.8\text{N}\cdot\text{m}$.

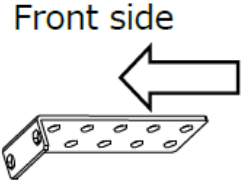

7.0 How to Change the Bracket Position

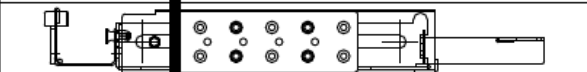
7.1 The mounting position on the MPO Cassette panels selectable by moving the bracket position as shown in below table below. Refer to the table below and specify the position of the bracket. Fix the bracket with four screws. Recommended tightening torque is 2.0N·m.

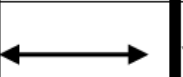
Direction of the bracket	Fixing position of the bracket	projecting length (mm)
Front side 		66.8 (original position)
		91.8
		116.8
		

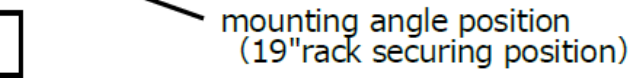
 mounting angle position (19"rack securing position)

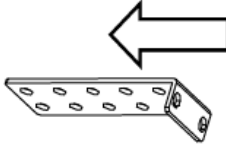
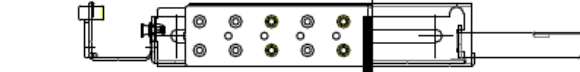
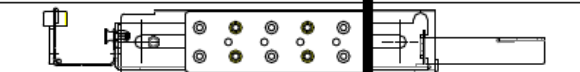
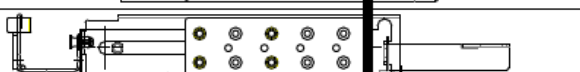
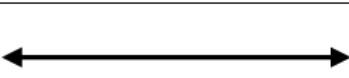
Direction of the bracket	Fixing position of the bracket	projecting length (mm)
Front side 		203.8
		228.8
		253.8
		

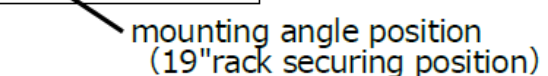
 mounting angle position (19"rack securing position)

7.2 Attach the product to the 19"rack at four locations using the attached screws.

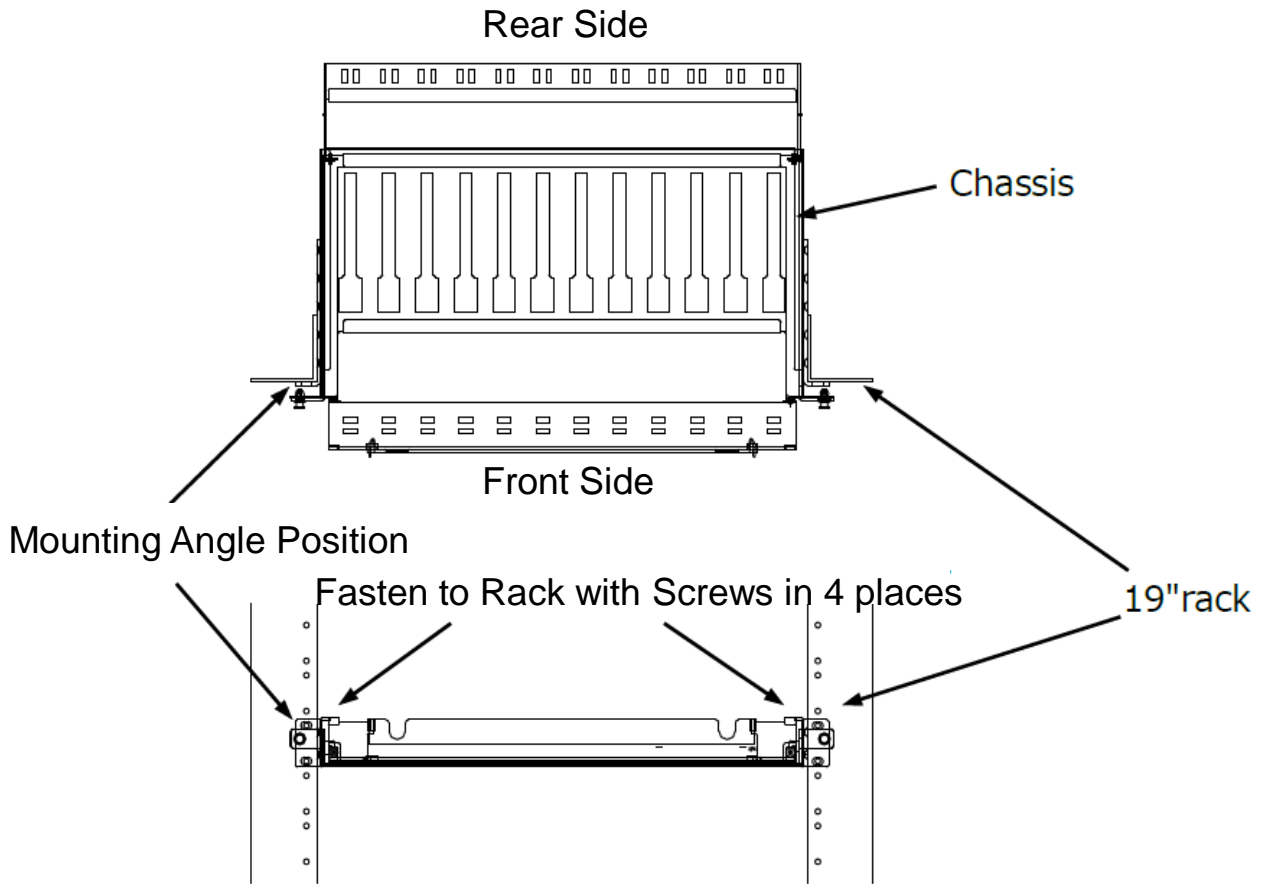

*When using a fixed chassis (PFCST-1U-F12-BK), please install it on a 19-inch rack with a space of 1U or more above and below. If there is no space between them, the clip operation when attaching and detaching the MPO Cassette Module (step 5.4 and 5.5 above) and the LC adapter pop-up operation of the MPO Cassette Module (figure below) will not be possible.



LC adapter pop-up operation for MPO cassette