

## SUMITOMO RECOMMENDED PROCEDURE

### SRP SP-F04-029



## PLENUM-RATED JACKETED TUBE CABLE TCxxTP2 INSTALLATION PROCEDURES

<u>PARA.</u>	<u>CONTENTS</u>
1.0 2.0 3.0 4.0	General Safety Precautions Reference Documents Equipment / Tools Required
5.0 6.0 7.0 8.0 9.0 10.0 11.0 12.0 13.0 14.0 15.0	Reel Handling and Storage On-Reel Obstruction Testing Pre-Installation Preparations Route Orientation Tube Cable Management Placement of Tube Cables Installation Methods Post-Installation Obstruction Testing Final Tube Cable Installation Pressure and Obstruction Testing Fiber Bundle Installation
	<u>ADDENDUM A</u> Physical Characteristics Specifications Tube Cable Reel Data Standard Fiber Bundle Blowing Distances

SUMITOMO ELECTRIC LIGHTWAVE CORP.  
201 South Rogers Lane, Suite 100, Raleigh, NC 27610  
(919) 541-8100 or 1-800-358-7378  
www.sumitomoelectriclightwave.com

SEL is a Member of the Sumitomo Electric Industries, Ltd. Group

*Sumitomo Electric Lightwave reserves the right to improve or modify these specifications without notice.*

## 1.0 General

1.1 This procedure provides the special installation requirements necessary to achieve a successful Plenum-Rated Jacketed FutureFLEX Tube Cable installation.

1.2 The Plenum-rated jacketed tube cables are designed for use in indoor applications requiring an Optical Fiber Nonconductive Plenum (OFNP) fire rating and are in compliance with NFPA 262 / CUL FT6 / CSA OFN (FT6) requirements.

1.3 The Plenum-rated jacketed tube cables are designated as Sumitomo Part Number TCxxTP2 (where xx = tube count). The TP2 tube cables are available in 02, 04, 07, 12, and 19-tube count designs.

1.4 Refer to the **FutureFLEX Air-Blown Fiber Products List** and **Addendum A** in this SRP for additional important information concerning the Physical Characteristics, Specifications, and Tube Cable Reel Data applicable to the various TP2 tube cable designs and sizes.

## 2.0 Safety Precautions

2.1 The use of personal safety equipment is strongly recommended while testing and installing tube cable and cutting/stripping tube cable ends. This includes the use of proper footwear, cut-resistant Kevlar gloves, and eye wear with side-shields.

## 3.0 Reference Documents

3.1 Sumitomo Recommended Procedure, *FutureFLEX Tube Pressure Testing Procedure*, SRP SP-F04-003.

3.2 Sumitomo Recommended Procedure, *FutureFLEX Tube Obstruction Testing Procedure*, SRP SP-F04-004.

3.3 Sumitomo Recommended Procedure, *FutureFLEX Tube Cable Installation Procedures*, SRP SP-F04-008.

3.4 Sumitomo Recommended Procedure, *FutureFLEX Tube Cable Splicing Procedures*, SRP SP-F04-031.

3.5 Sumitomo Recommended Procedure, *FutureFLEX Installation Procedures for Strain Relief Kellems Grips*, SRP SP-F04-037.

3.6 Sumitomo Recommended Procedure, *FutureFLEX Installation Procedures for Cable Entry Seals*, SRP SP-F04-038.

## 4.0 Equipment / Tools Required

4.1 4.0mm OD Plastic Beads (BEBB40P)

4.2 Tube Plugs (Blue color) (DE55MP)

4.3 Heat Shrink End Caps

- For 2- to 4-tube cables (DE04HS1)
- For 7-tube cables (DE07HS1)
- For 19-tube cables (DE19HS1)
- For 24-tube cables (DE19HS2)

4.4 Utility Knife with Hook Blade (Installer provided)

4.5 Tube Cable Cutter (BETL03)

4.6 Tubing Cutter (BETC001)

## 5.0 Reel Handling and Storage

5.1 Reels shall be used which adequately protect the TP2 tube cables from damage during handling and while in storage.

5.2 Tube cable reels shall be shipped and stored with the flanges vertical. Do not lay TP2 reels flat. Always forklift by flanges only.

5.3 The open ends of individual tubes and tube cables should always be kept sealed with plastic caps, plugs, correct size heat shrink end caps, or other appropriate sealing methods to protect the interior of the tubes and tube cable from contamination during handling and storage at all times.

5.4 TP2 tube cable reels should be stored indoors. If stored outdoors, the tube cable reels must be covered with an appropriate outer wrapping to avoid direct exposure to sunlight and moisture. Long term exposure to UV rays from the sun can degrade the burn performance characteristics of the jacketing material.

The SEL Warranty shall be voided if the TP2 tube cable reels are stored outdoors in an unprotected manner.

5.5 If TP2 tube cable is re-spooled onto other than the original SEL reels, reel drum diameters must be at least 20 times (20X) the tube cable outer diameter.

5.6 Always handle TP2 tube cable reels with care to safeguard against possible damages. Do not drop the reels and do not roll them for long distances.

5.7 Whenever a tube cable reel is received, perform a Visual Receipt Inspection of the reel and its contents. Look for obvious signs of damage that may have occurred during shipping, handling, or storage such as broken wood, breaks, dents, or rips in the protective wrapping, etc. If damage is noted, notify proper authority immediately.

## 6.0 On-Reel Obstruction Testing

6.1 It is strongly recommended that all tubes of the TP2 tube cables be Obstruction Tested while still on the reel. This will verify that no shipping or storage damaged occurred to the tubes and that the tube cable is in good shape prior to installation. If problems are detected on the reel, notify proper authority immediately.

6.2 Both ends of the tube cable are accessible on the reel. Remove the protective sealing devices (heat shrink end caps, plugs, etc.) from both tube cable ends. Use a Hook Blade Knife to lightly score tube cable jacket. Pull ripcord and strip jackets away to expose individual tubes. Use a Tubing Cutter to ensure the tube ends are cut straight and clean.

6.3 Refer to Sumitomo Recommended Procedure, *FutureFLEX Tube Obstruction Testing Procedure*, SRP SP-F04-004 and perform standard obstruction test procedures on the TP2 tube cables using a 4.0mm OD Plastic Beads BEBB40P. (Note: All other tube cable types use a 5.0mm OD Plastic Bead [BEBB01P] for obstruction testing.)

6.4 Document the test results, re-seal the tube cable ends, and re-apply the reel's protective covering.

## 7.0 Pre-Installation Preparations

7.1 Prior to any tube cable installation operation, the specifications for the tube cable and the installation must be checked to confirm the following:

- Maximum allowable pulling tension
- Cable outside diameter
- Minimum allowable bending radius during installation (20X tube cable OD)
- Minimum allowable bending radius after installation (10X tube cable OD)
- Cable weight
- Supply length of cable
- Cable Reel Data (size, weight, etc.)

7.2 For TP2 tube cables, the above information can be obtained by consulting the **FutureFLEX Air-Blown Fiber Products List..**

## 8.0 Route Orientation

8.1 A key aspect of installing any tube cable that will result in maximum blowing performance is to always install the cable in a manner which provides for the straightest route and fewest bends possible.

8.2 Avoid unnecessary tight bends whenever possible but be sure to provide slack footage as needed for thermal effects. See Sumitomo Recommended Procedure, *FutureFLEX Tube Cable Installation Procedures*, SRP SP-F04-008.

8.3 Always avoid sharp S-curves as they present the highest resistance to good blowability.

## 9.0 Tube Cable Management

9.1 Due to the material composition of TP2 tube cables, special support methods and installation practices are required to be used along the tube span route to prevent deformation of the tubes caused by sag and pinch points.

9.2 Cable Trays - Solid cable trays or trays with flat inserts in the bottom are the preferred method to provide TP2 tube cables with a flat and continuous support throughout their entire run length.

9.3 Flex-Wire Basket Trays – Flex-Wire Basket Trays may be used to support TP2 tube cables provided the wire / basket mesh size is no more than 4-inches long and 2-inches wide. If the wire mesh size is greater than specified, place flat inserts in the bottom of the Tray to provide a flat and continuous support.

9.4 Ladder Trays – Ladder Trays may be used to support TP2 tube cables provided the spacing between the ladder rungs is no more than 12-inches apart and the rungs are at least 1-inch wide. If rung spacing is greater than specified, place flat inserts across the rungs to provide a flat and continuous support.

9.5 Adjustable Cable Supports – Adjustable cable supports that utilize a cloth or fabric type strap to support cables are not an acceptable support method for TP2 tube cables unless you are installing armored tube cable.

The small surface area of the strap will cause deformation of the cable as it enters and exits the strap surface.

9.6 J-Hooks – J-Hooks *by themselves* are not an acceptable support method for TP2 tube cables. The small surface area of the hook will cause deformation of the cable as it enters and exits the hook surface. Pentair, Legrand, and others provide multiple types of mounted cable tray options. A popular example is Mono-Systems' J-Tray(See **Figure 1A**). This continuous support along the tray ensures the tube cables will not sag and become damaged over time.

9.7 J-Hooks with Innerduct – J-Hooks can be used to support TP2 tube cables provided the J-Hooks are spaced no more than 4- to 5-feet apart and a minimum 10-to-12 inch long piece of Innerduct is placed around the tube cable as it lays in each J-Hook. The Innerduct piece must be centered in the hook to provide good support as the cable enters and exits the narrow J-Hook area thus spreading out the linear loading of the tube cable. Additionally, the tube cable shall be installed with no more than 6" sag between the J-Hooks. **See Fig. 1.**

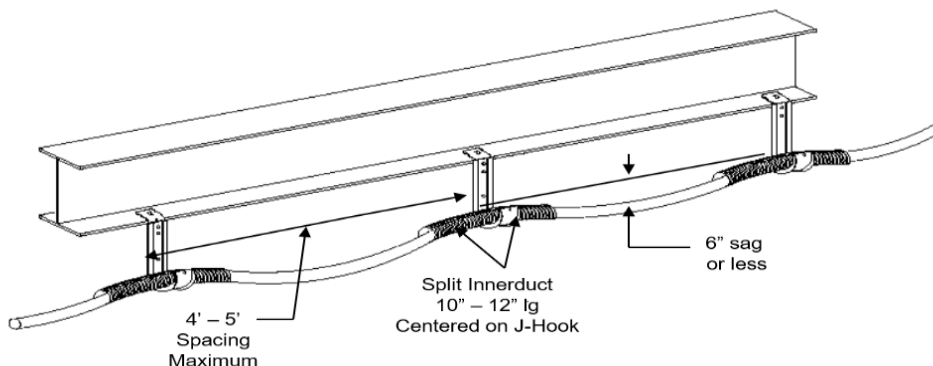

**Figure 1**  
J-Hook Supports with Split Innerduct



Figure 1A J-Tray by Mono Systems

9.7.1 Use a Plenum-rated, Corrugated, Split Innerduct to support the TP2 tube cables as they rest in J-Hooks. The following sizes are required:

- Carlon Electrical Division 1-1/4" Plenum-rated, Corrugated, Orange, Split Innerduct CF4X1-250S (or equal) for 1" OD TC07TP2
- Carlon Electrical Division 2" Plenum-rated, Corrugated, Orange, Split Innerduct CF4X1-250S (or equal) for 1.7" OD TC19TP2

9.7.2 During installation, ensure the "split" points upward and the Innerduct sections lock together to provide the best support for the tube cable.

9.7.3 An alternative method would be to cut standard (non-split) corrugated Innerduct into 1-foot lengths and carefully slit them as required. Again, ensure the slit points upward.

9.8 Velcro Strapping – Velcro strapping shall be the only material used to secure TP2 tube cables in place. However, Velcro strapping should not be used to support the weight of a TP2 tube cable as the strap will present a narrow point load on the tubes which can cause them to deform.

9.9 Nylon Tie-Wraps - Never use nylon tie-wraps on TP2 tube cables for any reason. Tie-Wraps can be too easily over-tightened and present a very narrow point load on the tubes which can cause them to deform. Do not use nylon-tie-wraps on TP2 tube cables even as a temporary support measure during initial tube cable placement for the same reasons.

9.10 Transition Supports - When TP2 tube cables transition on to or off a Cable, Ladder, or Flex-Wire Tray, special attention must be given to the transition method in order to provide a smooth, flat, and continuous support under the cable. Some type of "Waterfall" product with at least the same minimum bending radius of the tube cables installed must be used to avoid sharp edges (pinch points) at, for example, the first or last ladder rung and to provide continuous support for the tube cables in the bend.

## 10.0 Placement of Tube Cables

10.1 Placement of TP2 tube cables along the supported route is critical to avoid excessive compressive loading.

10.2 Always place larger, heavier TP2 tube cables on the bottom layer and smaller, lighter TP2 tube cables on the top layer. Another acceptable method is to stagger large and small tube cables to distribute loading. Never stack more than two (2) TP2 cables high. **See Fig. 2.**

10.3 Do not place any ... *repeat* ... any metallic cables on top of TP2 tube cables. Again, the key concern is excessive compressive loading. It is best to separate and segregate TP2 tube cables with their own routing to avoid long-term problems.

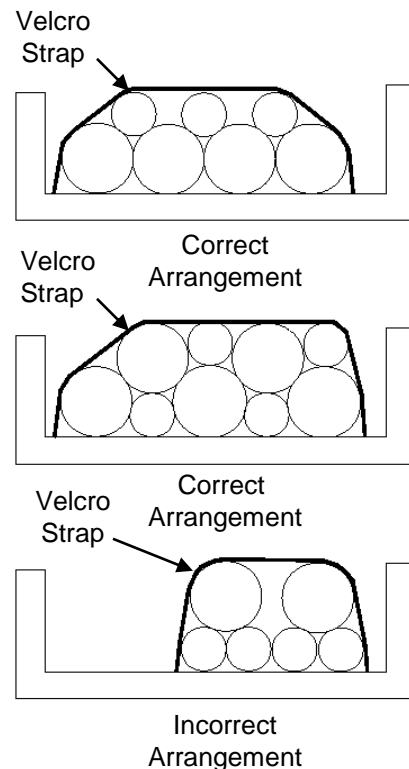

**Figure 2**  
Stacking Arrangements  
for Multiple TP2 Cables in Trays

10.4 When TP2 tube cables must cross each other, use of a “Waterfall” type product to bridge or transition one cable up and over the other. This method will prevent the weight of the upper cable from laying on the lower cable and possibly deforming the tubes. **See Fig. 3.**

10.5 If more than one TP2 tube cable is supported in a J-Hook, the Split Innerduct piece may be placed around the lowest tube cable(s) only; the one(s) that rests in the J-Hook. The upper tube cables should rest on top of the Split Innerduct piece. **See Fig. 4.**

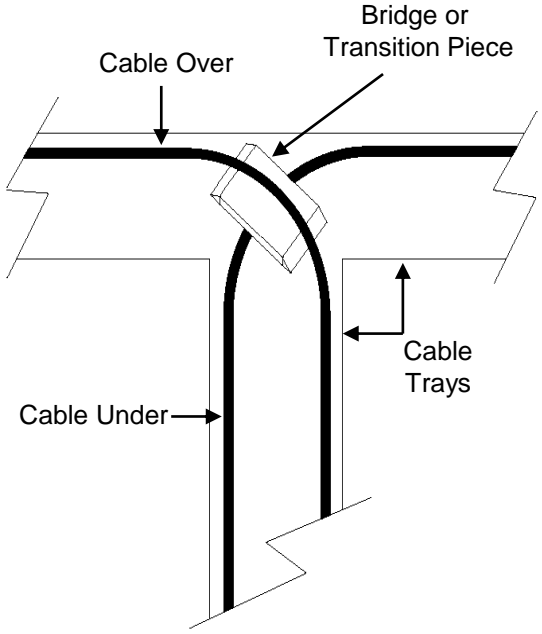

**Figure 3**  
Tube Cables Crossing  
Using Bridge or Transition Piece

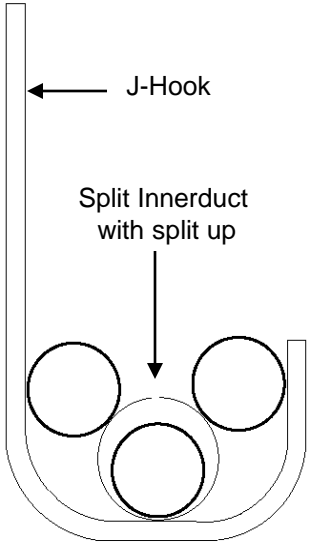

**Figure 4**  
J-Hook and Split Innerduct

10.6 TC02TP2, TC04TP2, TC07TP2, TC12TP2 and TP19TP2 tube cables are not round. They have distinct flat surfaces and raised points due to the orientation / design.

10.7 Always place the flat surfaces of TP2 tubes cables down so they do not rest on their points. **See Fig. 5.**

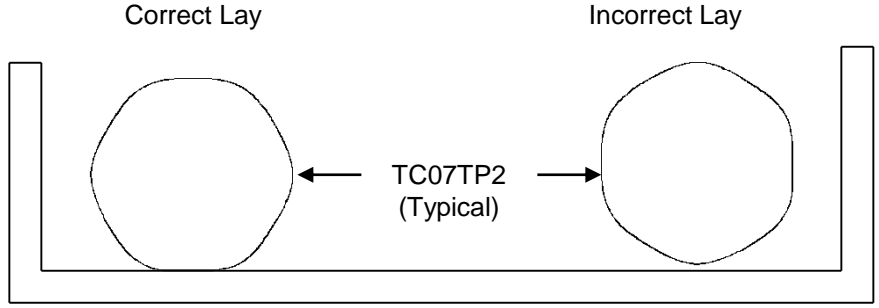

**Figure 5**  
Lay TP2 Tube Cables Flat and Not On Their Points

## 11.0 Installation Methods

11.1 Before any TP2 tube cable installation effort begins, carefully inspect all areas of the route to ensure there are no sharp edges or abrasive supports (e.g.: threaded rods, attachment bolts, etc.) that could cause damage to the tube cable if contact is made.

11.2 See Sumitomo Recommended Procedure, *FutureFLEX Tube Cable Installation Procedures*, SRP SP-F04-008 for acceptable cable pulling techniques.

11.3 Manual installation of TP2 tube cables is preferred. The tube cable should always be pulled in a straight direction without bending.

11.4 If pulling ropes or strings are used, a swivel should always be used between the cable grip and the pulling rope to prevent the cable from twisting during installation. The swivel selected should be one of quality workmanship that can withstand the maximum allowed pulling tension and still allow pivoting about its axis.

11.5 TP2 tube cables must never be pulled over sharp edges such as ladder rungs, angle iron, and so forth. Some type of hard and rounded temporary protective covering (e.g.: Split Innerduct, a Roller Wheel, a temporary Waterfall or Bridge product, etc.) must be secured over these sharp points if there is any chance the tube cable will come in contact with them during the installation effort .

Additionally, ensure the protective devices are firmly attached over these edges so they will not be pulled loose as the tube cable moves across it. If the tube cables will remain on these sharp points, install a permanent Waterfall or Bridge product. **See Fig. 6.**

11.6 Do not have plenum tubes entering horizontally into a Tube Distribution unit box with a cable entry seal without the proper support nearby. Over time, a horizontally mounted plenum cable will expand/contract and gravity will cause damage to the tubing pathway. Instead, enter vertically into a TDU box or provide adequate continuous support near cable entry seals for the plenum tubing in your pathway. Alternatively, you can also choose to not use a heat shrink gun to shrink down the Cable Entry Seal on horizontally mounted plenum tube cables.

## 12.0 Post-Installation Obstruction Testing

12.1 After the initial TP2 tube cable installation has been completed, it is recommended to perform another Obstruction Test on all the tubes.

12.2 This recommended testing should be performed before any tubes are coupled or any clamps or fittings have been installed. Successful test results verify that the TP2 tube cables were not damaged during the installation effort.

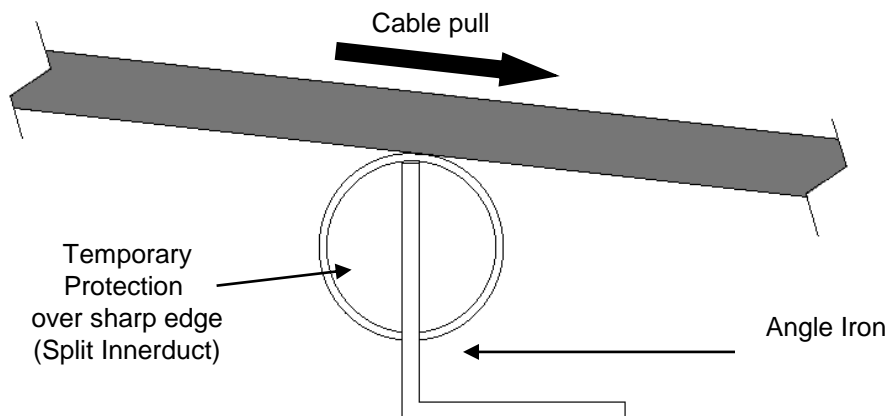

**Figure 6**  
Install Temporary Protective Coverings  
Over Sharp Edges During Cable Pull-in

12.3 Refer to Sumitomo Recommended Procedure, *FutureFLEX Tube Obstruction Testing Procedure*, SRP SP-F04-004 and perform standard obstruction test procedures on the TP2 tube cables using a 4.0mm OD Plastic Bead BEBB40P. Metal Ball Bearings are **NOT** authorized for use. (Note: All other tube cable types use a 5.0mm OD Plastic Bead [BEBB01P] for obstruction testing.)

12.4 Document the test results and, if any problems are detected, notify proper authority immediately.

### 13.0 Final Tube Cable Installation

13.1 During the final TP2 tube cable installation (dress out) effort, re-inspect the entire route for any potential problems and correct immediately. For example: Add 1-foot long Split Innerduct pieces if J-Hooks were used. Verify there is 6 inches or less of cable sag between J-Hooks if used. Verify no TP2 tube cable is in contact with any sharp point or edge such as bolts, etc. Verify TP2 tube cables are laying on their flat surfaces and not on their points. Install Velcro strapping as required to secure and organize the TP2 tube cables but not to support them.

13.2 The ends of a TP2 tube cable segment must be securely attached / anchored to a Tube Distribution Unit (TDU), Fiber Termination Unit (FTU), or wall / structure to minimize tube cable sagging along the installed route. Use of the following SEL fittings (below) is recommended.

13.2.1 Use Strain Relief Kellems® Grips to secure TP2 tube cables to an indoor TDU only where a strain relief application is required and the TDU is not subject to hosing, splashing, or flooding: P/N DEDTSR1 for TC02TP2, TC04TP2, and TC07TP2 and P/N DEDTSR4 for TC19TP2. See SRP SP-F04-037 Installation Procedures for Strain Relief Kellems Grips.

13.2.2 Use Heat-Shrinkable Cable Entry Seals to secure TP2 tube cables to an indoor TDU only and where strain relief is not required: P/N DECES3 for TC02TP2, TC04TP2, and TC07TP2 and P/N DECES4 for TC19TP2. See SRP SP-F04-038 Installation Procedures for Cable Entry Seals.

13.3 Tube Clip Organizers – Tube Clip Organizer DETC008 may be used to help manage tube routing inside TDUs and FTUs if desired. Avoid excessive bending of the tube as it enters and exits the Tube Clip Organizer. Use care when installing or removing the tube from the clip to avoid damaging the TP2 tubes.

13.4 Tube Plugs – Use Tube Plug DE55MP to seal the open end of an empty TP2 tube. Tube Plug DE55MP is blue in color and designed to fit the smaller 5.5mm ID TP2 tubes. (Tube Plug DE06MP is orange in color and designed to fit the larger 6.0mm ID tubes.)

### 14.0 Pressure and Obstruction Testing

14.1 After the TP2 tube cable installation is complete, mandatory testing of all the tubes is required.

14.2 Refer to Sumitomo Recommended Procedure, *FutureFLEX Tube Pressure Testing Procedure*, SRP SP-F04-003 and perform standard pressure test procedures using **100 psi test pressure only**. (All other tube cable types use 150 psi test pressure.)

14.3 Refer to Sumitomo Recommended Procedure, *FutureFLEX Tube Obstruction Testing Procedure*, SRP SP-F04-004 and perform standard obstruction test procedures on the TP2 tube cables using a **4.0mm OD Plastic Bead** BEBB40P. (Note: All other tube cable types use a 5.0mm OD Plastic Bead [BEBB01P] for obstruction testing.)

14.4 Document all test results and, if any problems are detected, notify proper authority immediately.

### 15.0 Fiber Bundle Installation

15.1 It is strongly recommended to repeat the Obstruction Test on individual tubes before installing fiber bundle through that tube. This will verify that no unauthorized changes or damaged has occurred to the tube since the last successful tests were performed.



15.1.1 Refer to Sumitomo Recommended Procedure, *FutureFLEX Tube Pressure Testing Procedure*, SRP SP-F04-003 and perform standard pressure test procedures using **100 psi test pressure only**. (Note: All other tube cable types use 150 psi test pressure.)

15.1.2 Refer to Sumitomo Recommended Procedure, *FutureFLEX Tube Obstruction Testing Procedure*, SRP SP-F04-004 and perform standard obstruction test procedures on the TP2 tube cables using a 4.0mm OD Plastic Bead BEBB40P. Metal Ball Bearings are **NOT** authorized for use. (All other tube cable types use a 5.0mm OD Plastic Bead [BEBB01P] for obstruction testing.)

15.2 Fiber bundle installation procedures for TP2 tube cables are identical to any other tube cable type. However, do not exceed **150 psi Air Flow pressure** in the tube span during fiber bundle installation operations. Refer to the FutureFLEX Air-Blown Products List for standard blowing distances for TP2 tube cables.

15.3 Fiber Bushings – Use Fiber Bushings FT2MFB or FB3MFB to seal the end of a filled (fiber bundle installed) TP2 tube. Fiber Bushing FT2MFB is used for (2mm OD) fiber bundles. Fiber Bushing FT3MFB is used for (3mm OD) fiber bundles.

**ADDENDUM A  
 PLENUM-RATED JACKETED TUBE CABLE DATA**

**INDOOR FIRE-RATED TUBE CABLES**

Plenum-rated jacketed tube cables are designed for use in indoor applications requiring an Optical Fiber Nonconductive Plenum (OFNP) fire rating and are in compliance with NFPA 262 / CUL FT6 / CSA OFN (FT6) requirements.

<b>TC02TP2</b>
<ul style="list-style-type: none"> <li>• Grey tubes</li> <li>• Tube dimensions are 8mm OD and 5.5mm ID</li> <li>• Individual tubes numbered every 2 inches (1, 2)</li> <li>• Non-woven glass fiber tape wrap around tube bundle</li> <li>• Aramid yarn ripcord</li> <li>• Grey outer jacket</li> <li>• Print String and length mark information every 2 feet</li> </ul>

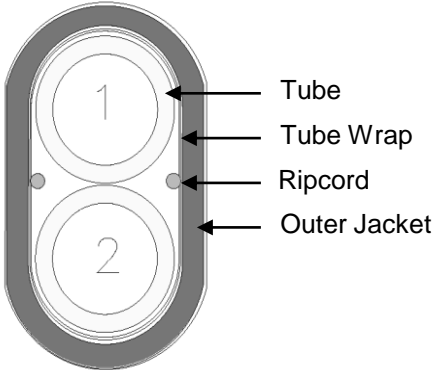

**Cross Section**  
 2-Tube  
 TC02TP2  
 Drawing Not to Scale

<b>TC04TP2</b>
<ul style="list-style-type: none"> <li>• Grey tubes</li> <li>• Tube dimensions are 8mm OD and 5.5mm ID</li> <li>• Individual tubes numbered every 2 inches (1 thru 4)</li> <li>• Grey or black PVC Central Member to retain square 4-tube shape</li> <li>• Non-woven glass fiber tape wrap around tube bundle</li> <li>• Aramid yarn ripcord</li> <li>• Grey outer jacket</li> <li>• Print String and length mark information every 2 feet</li> </ul>

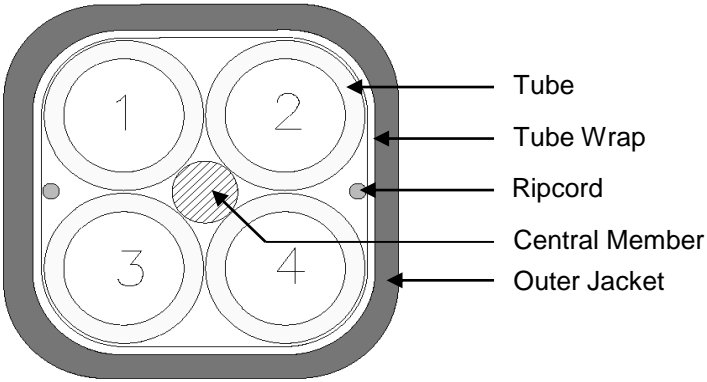

**Cross Section**  
 4-Tube  
 TC04TP2  
 Drawing Not to Scale

<b>TC07TP2</b>
<ul style="list-style-type: none"> <li>• Grey tubes</li> <li>• Tube dimensions are 8mm OD and 5.5mm ID</li> <li>• Individual tubes numbered every 2 inches (1 thru 7)</li> <li>• Non-woven glass fiber tape wrap around tube bundle</li> <li>• Aramid yarn ripcord</li> <li>• Grey outer jacket</li> <li>• Print String and length mark information every 2 feet</li> </ul>

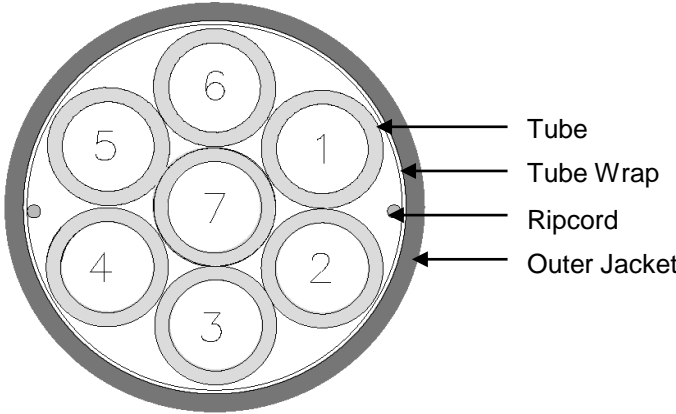

**Cross Section**  
 7-Tube  
 TC07TP2  
 Drawing Not to Scale

<b>TC12TP2</b>
<ul style="list-style-type: none"> <li>• Grey tubes</li> <li>• Tube dimensions are 8mm OD and 5.5mm ID</li> <li>• Individual tubes numbered every 2 inches (1 thru 7)</li> <li>• Non-woven glass fiber tape wrap around tube bundle</li> <li>• Aramid yarn ripcord</li> <li>• Grey outer jacket</li> <li>• Print String and length mark information every 2 feet</li> </ul>

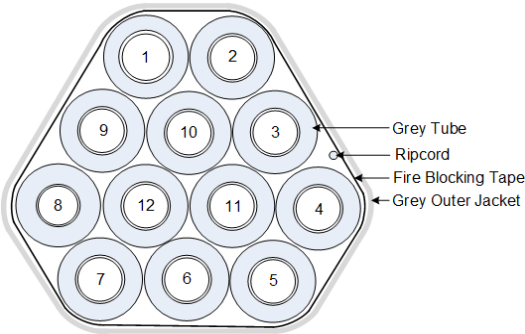

12-Tube  
 Plenum Rated  
 TC12TP2

<b>TC19TP2</b>
<ul style="list-style-type: none"> <li>• Grey tubes</li> <li>• Tube dimensions are 8mm OD and 5.5mm ID</li> <li>• Individual tubes numbered every 2 inches (1 thru 19)</li> <li>• Non-woven glass fiber tape wrap around tube bundle</li> <li>• Aramid yarn ripcord</li> <li>• Grey outer jacket</li> <li>• Print String and length mark information every 2 feet</li> </ul>

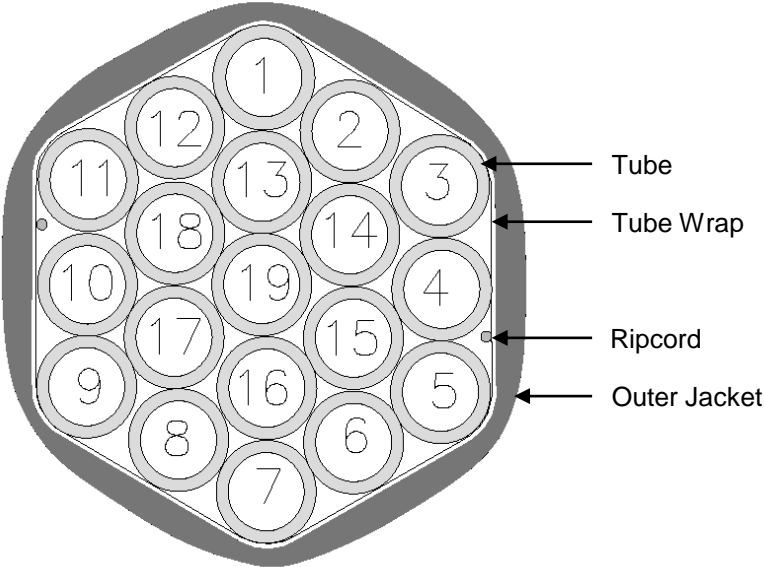

**Cross Section**  
 19-Tube  
 TC19TP2  
 Drawing Not to Scale

**PHYSICAL CHARACTERISTICS**

<b>Sumitomo Part No.</b>	<b>Cable OD (in.)</b>	<b>Max. Weight (lbs./kft)</b>	<b>Max. Tensile Load (lbs.)</b>
TC02TP2	0.8	105	120
TC04TP2	0.9	210	See Note Below
TC07TP2	1.0	320	400
TC12TP2	1.49	480	500
TC19TP2	1.7	574	500
TC24TP2	2.02	793	500

**Notes:**

Tensile load for TC04TP2 tube cables is 200 lbs. with standard basket weave grip or 500 lbs. with pulling eye.

**SPECIFICATIONS**

<b>Property</b>	<b>Specification</b>
Operation Temperature Range	-20° F to +158° F (-29° C to +70° C)
Minimum Bend Radius for Multi-Tube Cables (During Installation)	20X cable outside diameter
Minimum Bend Radius for Multi-Tube Cables (After Installation)	10X cable outside diameter
Minimum Bend Radius for Single Tubes (During and After Installation)	9" Radius

**TUBE CABLE REEL DATA**

Sumitomo Part No.	Std. Reel Length (ft)	Std Reel H x W (in)	Minimum Drum Diameter (in)	Std Reel Weight (lbs.) Empty	Std Reel Weight (lbs.) Full
TC02TP2	1000	36 x 17	18	55	144
TC04TP2	1000	54 x 20	40	116	326
TC07TP2	1000	54 x 36	40	137	457
TC12TP2	1000	60 x 42	40	420	890
TC19TP2	1000	60 x 49	40	420	1170

**Notes:**

- TP2 tube cables are only available in 1000-foot Standard Reel Lengths
- Cut Lengths are available. Contact FutureFLEX Distributor for additional information.
- Standard Reel Length tolerances are  $\pm 5\%$ .
- All Reel Widths shown are approximate values only and measured from outside-of-flange to outside-of-flange.
- If tube cable is re-spoiled, the Minimum Drum Diameter of the new reel **SHALL** be as shown to avoid damaging tube cable product
- All Empty and Full Reel Weights shown are approximate values only.

**STANDARD FIBER BUNDLE BLOWING DISTANCES USING ONE (1) BLOWING HEAD**

2, 4, 6 & 12 Fiber Bundles (2mm OD)	Approx. Blowing Distance
TP2 (Plenum) tube cables	500 meters or 1650 feet

24 Fiber Bundles (3mm OD)	Approx. Blowing Distance
TP2 (Plenum) tube cables	300 meters or 1000 feet

48 Fiber Bundles (4mm OD)	Approx. Blowing Distance
TP2 (Plenum) tube cables	230 meters or 750 feet

**Notes:**

- All distances given are approximate values.
- Several factors heavily influence actual blowing distances:
  1. The location, number, and severity of bends in a tube cable run.
  2. The fiber bundle size being installed (2mm OD or 3mm OD).
  3. The tube cable type.
- Extended Blowing Techniques can be used to install fiber bundles beyond the standard blowing distances or to help get fiber bundles through difficult tube routes (i.e.: those with numerous tight bends).