

Optical Fiber Fusion Splicer

TYPE-25eM/25eS/25eS-LC

Guide to Operation



This manual contains the handling, operation procedures and safety instructions concerning the TYPE-25e, used for the Last One Mile connection such as FTTH. Please read this manual before starting.

WARNING -FOR YOUR SAFETY-

To reduce the risk of, electric shock or injury to persons, please follow this operation manual.

IMPORTANT

This manual contains the important information concerning the software license.

Please read this manual before starting.

1. General

The TYPE-25e Compact Fusion Splicer can splice optical fiber and reinforce the spliced portion by curing a protection sleeve with heat. Inspection is automatically performed on fiber by built-in microscope during the splicing process.



Read this manual in its entirety to understand fully the machine capabilities. Save this manual in a location in which you can easily get to see.

Product

There are 3 models in the TYPE-25e series. Note that the specification is different depending on the model. (Further details are described in the next chapters.)

Optical fiber require-

	TYPE-25eM	TYPE-25eS	TYPE-25eS-LC	
Material	Silica glass			
Profile type	SMF, MMF, DSF, NZDSF			
Fiber count	1.2.4	1		
Fiber diameter	125 μ m			
Coating diameter	0.25mm, 0.5mm, 0.9mm	0.25mm	0.9mm tight-buffer	0.9mm loose-buffer
Cleave length	10mm	10mm	10mm	Total 20-22mm(10mm of bare fiber and 10mm of 250 μ m fiber)

Features over-

The TYPE-25e key features are:

- *High speed splicing*
11 seconds for single fiber, 15 seconds for 4-fiber ribbon
- *Easy and simple AC operation*
AC adapter is connected to TYPE-25e directly.

- *Built-in battery charger*
The TYPE-25e has a battery charger built-in and plug the AC adapter to charge batteries.
- *Power saving technology*
The TYPE-25e with power saving feature enables 60 splice cycles (splice & protection) per fully charged battery.
- *USB interface*
USB1.1 connector is provided for TYPE-25e.

Standard pack-

When unpacking, check to make sure that the following items have been included.

Part name	Part No.	Unit	TYPE-25eM	TYPE-25eS	TYPE-25eS-LC
Fusion splicer	TYPE-25e	pc.	1	1	1
Fiber holders	FHS-025 ^{*1}	pair	0	1	0
	FHM-4 ^{*2}	pair	1	0	0
Battery	BU-25	pc.	1	1	1
AC adapter	ADC-1240	pc.	1	1	1
Spare electrodes	ER-10	pair	1	1	1
Neck strap	—	pc.	1	1	1
V-groove cleaning brush	VGT-1	pc.	1	1	1
Operation manual ^{*3}	OME0624081	pc.	1	1	1
Carrying case	—	pc.	1	1	1

*1: Fiber holders for single fiber with 250 μm coating

*2: Fiber holders for 4-fiber ribbon

*3: The latest version is provided.

Preparing package items for

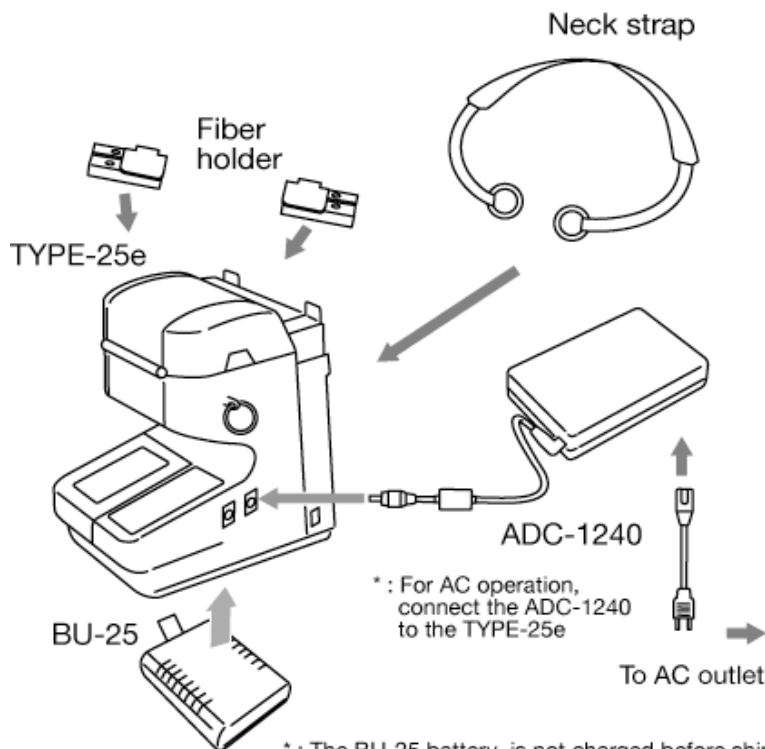

* : The BU-25 battery is not charged before shipment. Please charge it before use. The TYPE-25e has a built-in battery charger. If the ADC-1240 is connected to the TYPE-25e body in which BU-25 is installed, charging automatically starts. (When the power is OFF)

Optional accessories-

The following optional accessories are provided for the TYPE-25e. For further details, please contact our sales personnel.

Part name	Part No.	Description	TYPE-25eM	TYPE-25eS	TYPE-25eS-LC
<Optional accessories for main unit>					
Battery	BU-25	Li-Ion battery	○	○	○
Battery charger	BC-25A	Battery charger for BU-25 2 batteries can be charged simultaneously.	○	○	○
AC adapter	ADC-1635	AC adapter for BC-25A	○	○	○
Fiber holders	FHS-025	Fiber holders for single fiber with 0.25mm coating	○	○	X
	FHS-09	Fiber holders for single fiber with 0.9mm coating	○	○	X
	FHS-05	Fiber holders for single fiber with 0.5mm coating	○	○	X
	FHM-2	Fiber holders for 2-fiber ribbon	○	X	X
	FHM-4	Fiber holders for 4-fiber ribbon	○	X	X
	FHM-05-4	Fiber holders for 4-fiber ribbon arranged by 0.5mm fiber	○	X	X
Carrying case	CCS-25	Soft case	○	○	○
Cooling tray	FCT-25	Tray for cooling down heated protection sleeve	○	○	○
Dispenser	HR-3	Dispenser for alcohol	○	○	○
<Other accessories (preparation tools)>					
Fiber cleaver	FC-7	Fiber cleaver for single and ribbon fibers	○	○	○
	FC-6	Fiber cleaver for single and ribbon fibers	○	○	○
Jacket remover	JR-25	Jacket remover for single fiber	○	○	○
	JR-5	Jacket remover for ribbon fiber	○	—	X
	JR-5B	Battery-operated jacket remover for single and ribbon fibers	○	—	X
	BU-5B	Battery for JR-5B	○	—	X
	BC-5B	Battery charger for BU-5B	○	—	X

○: A circle marked in the table indicates that the item is applied to the model.

X: A cross marked in the table indicates that the item is not applied to the model.

—: A horizontal line drawn in the table indicates that the item also can be applied to the model.

Preparing optional accessories for

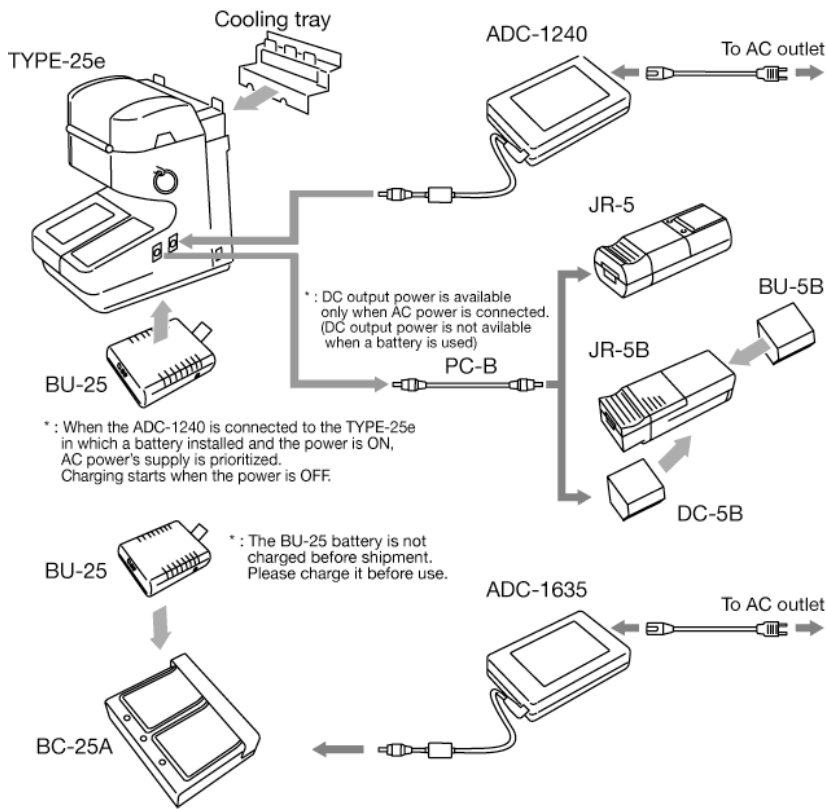

Consumables

Fiber protection sleeves, electrodes, and battery are consumables. Please place an order when necessary.

Part name		Part No.	TYPE-25eM	TYPE-25eS	TYPE-25eS-LC
Fiber protection sleeves	For single fiber 60mm	FPS-1	○	○	○
	For single fiber 40mm	FPS-40	○	○	○
	For ribbon fiber 40mm	FPS-5	○	○	○
	For ribbon fiber 40mm	FPS-6	○	○	○
Electrodes		ER-10	○	○	○
Battery		BU-25	○	○	○

○: A circle marked in the table indicates that the item is applied to the model.

- Regarding standard equipment, consumables, or optional accessories, please order the new item you need with the item description and part number to our sales personnel.

- For repair, please read "Warranty and repair service" at page 54 and contact our maintenance service center.

Structure

This section describes the name and function of each part of the TYPE-25e.

Fusion splicer



- 1 Main body**
TYPE-25e fusion splicer
- 2 Keypad**
Used to turn ON/OFF the splicer, perform a splice, initiate heating cycle and set a function.
- 3 Monitor**
Displays fiber image, splice data, message and menu. The viewing angle is adjustable for easy viewing in direct sunlight.
- 4 Hood**
Provides high quality splicing under various environmental conditions.
- 5 Heat shrink oven**
Used to heat and shrink fiber protection sleeves.
- 6 Battery compartment**
Battery BU-25 is installed in this compartment.
- 7 USB port**
Used to download stored splice loss data when connected to a PC.
- 8 DC input terminal**
Used to connect AC adapter ADC-1240.
- 9 DC output terminal**
Used to supply DC power to a heated jacket remover.
- 10 Ring for hook**
Used to hook a neck strap enabling hanging the splicer around an operator's neck or carrying it with a hand.

Key pad

Keypad control keys are used to perform the splicing process. Each key has the following function.

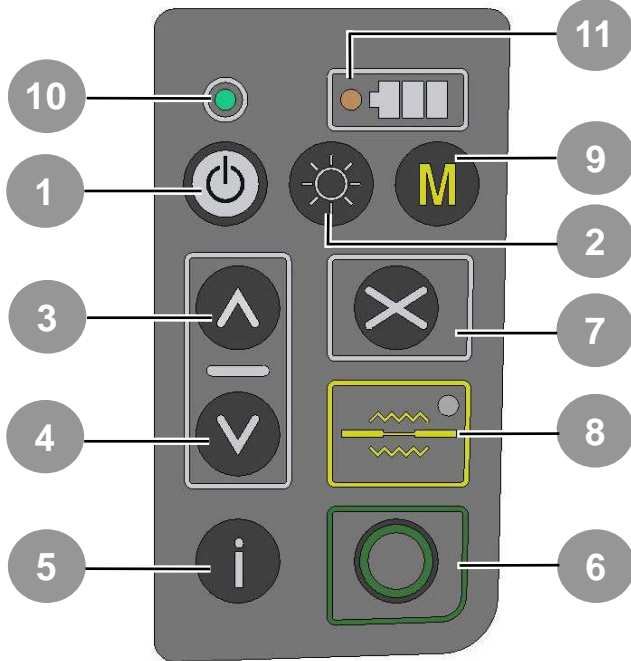

- 1 Power key**
Used to turn on and off the splicer.
- 2 Brightness control key**
Adjusts brightness of monitor.
- 3 Up arrow key**
Used to move cursor and enter numeric values.
- 4 Down arrow key**
Used to move cursor and enter numeric values.
- 5 Information key**
Used to switch Set Up/Ready screens and display troubleshooting messages.
- 6 SET (select) key**
Starts a splicing operation and confirms current selection.
- 7 RESET key**
Used to cancel a splicing operation. Initialization
- 8 Heat key**
Starts / cancels the heating cycle.
- 9 Maintenance key**
Used to change the splice/heating conditions and perform re-arcing of a completed splice.
- 10 Power LED**
LED illuminates while the splicer is on. LED flashes while the splicer is in Sleep mode.
- 11 Battery charge LED**
LED flashes while a battery is charged. LED illuminates when charging is complete.

Electrodes, V-grooves and peripheral

<TYPE-25eM and TYPE-25eS>

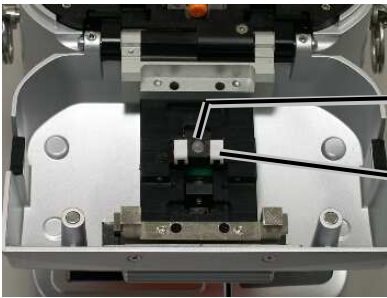
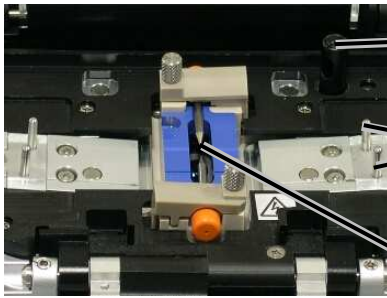
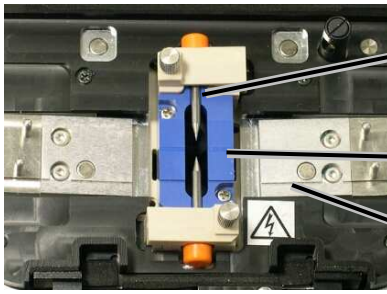

- 1 **Electrode**
An arc is generated between the electrodes. "ER-10" is used for the TYPE-25e.
- 2 **V-grooves**
Precisely designed to hold fibers.
- 3 **Z stage (right & left)**
Designed for fiber holder placement.
- 4 **Illumination LED for V-groove**
Illuminates the V-groove and helps fiber loading in dark workplaces.
- 5 **Fixing pins**
The pins that are fitted inside the hole of a fiber holder to place the holder on the Z stage.
- 6 **Microscope**
Used to observe fiber. (Positioned below the electrode.)
- 7 **Illumination LED**
Illumination for microscope
- 8 **Bare fiber pads**
Hold fibers seated into the V-grooves. Attached to the hood.

<TYPE-25eS-LC>

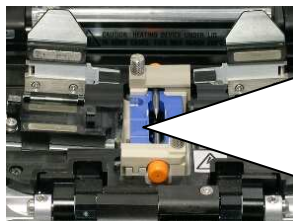

<Cleave length>

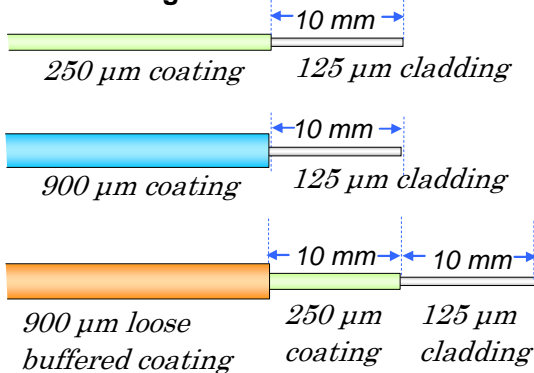

Enlarged view

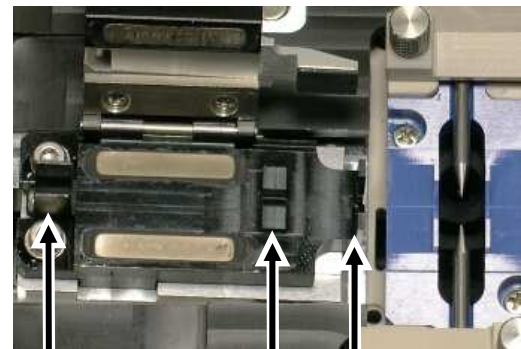

Rear guide Middle guide Front guide

1. Check the bare fiber length against the ruler on the coating clamp lid, ensuring the bare fiber end does not touch the splicer, and then open the coating clamp lid.
2. Carefully lower the fiber into the fiber guides, with the fiber end as close to the centre of the electrodes as possible. On 900μm loose-buffered fiber, the end of the 900μm coating should be just at the front of the middle fiber guide.

Heat shrink oven

The heat shrink oven is used to heat and shrink the fiber protection sleeve that is centered over the spliced portion.

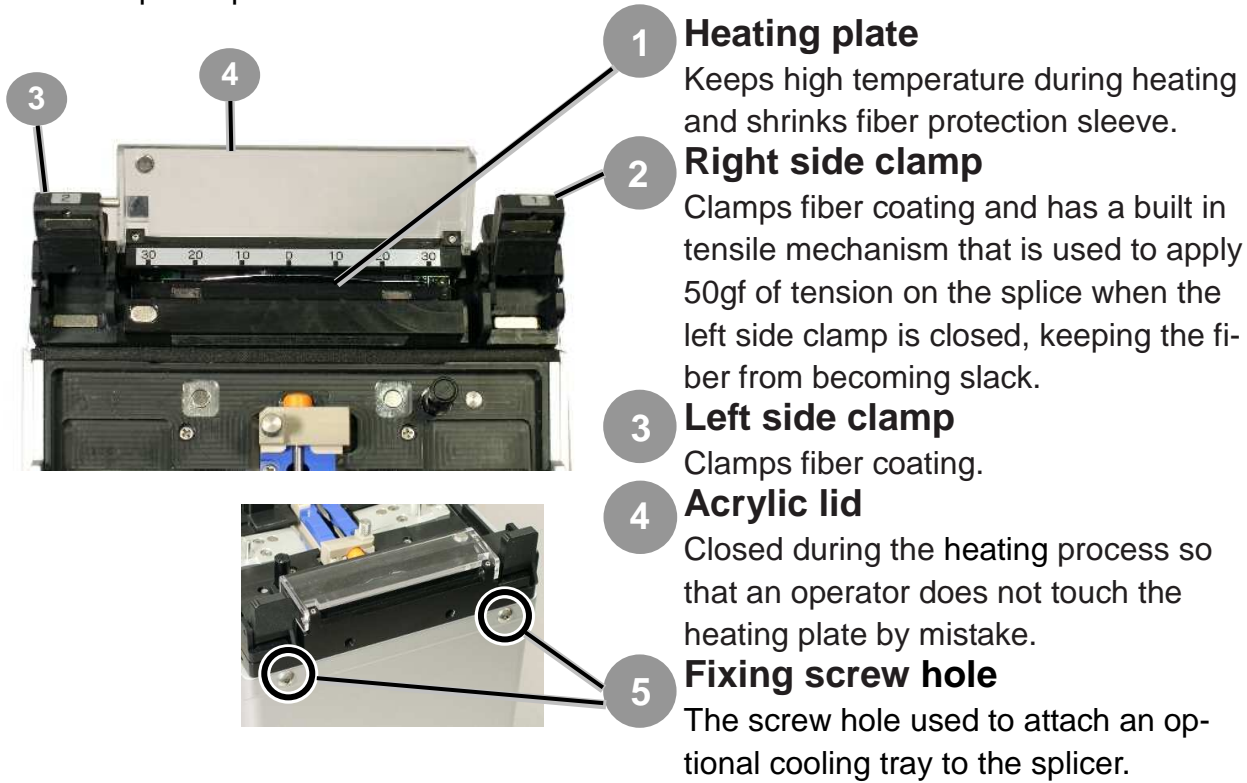

Battery charger BC-25A (op-

The BC-25A is a battery charger for the BU-25. Please see also page 14.

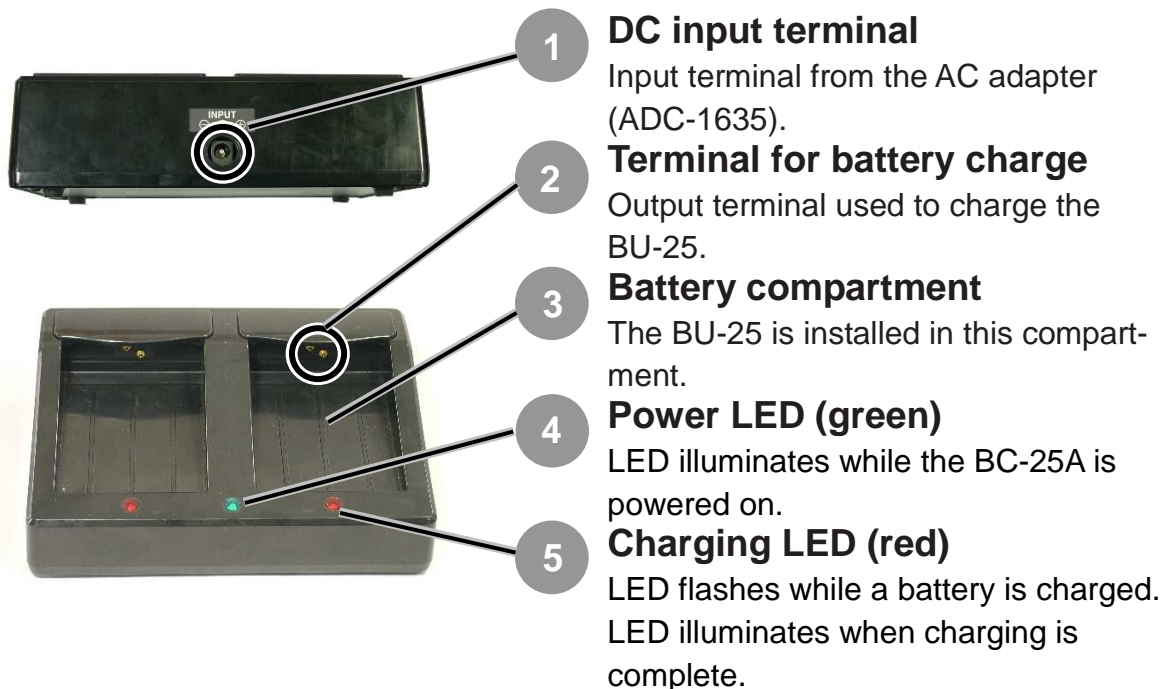

Cooling tray (option)

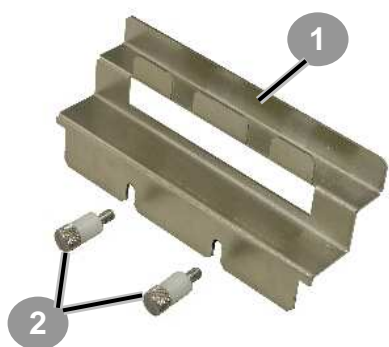

- 1 Cooling tray**
Cooling tray
- 2 Fixing screw**
The hand screw for holding the TYPE-25e.

How to use

Mount the cooling tray to the rear of the splicer. For further details, see page 30.



2. Splice / Protection

This Chapter describes basic splicing operation.

[Preparation for splicing]

Before splicing, collect all of the necessary equipment.

- TYPE-25eM / 25eS/ 25eS-LC
 - Jacket remover
 - Fiber cleaver
 - Pure (99%) alcohol
 - Lint-free gauze wipes
 - Fiber protection sleeves*
- *Note that the applicable fiber protection sleeves vary depending on the fiber being used.

[Operating proce-

The following is a summary of the steps required to make a splice with the splicer. The details of each step are described in the next pages.

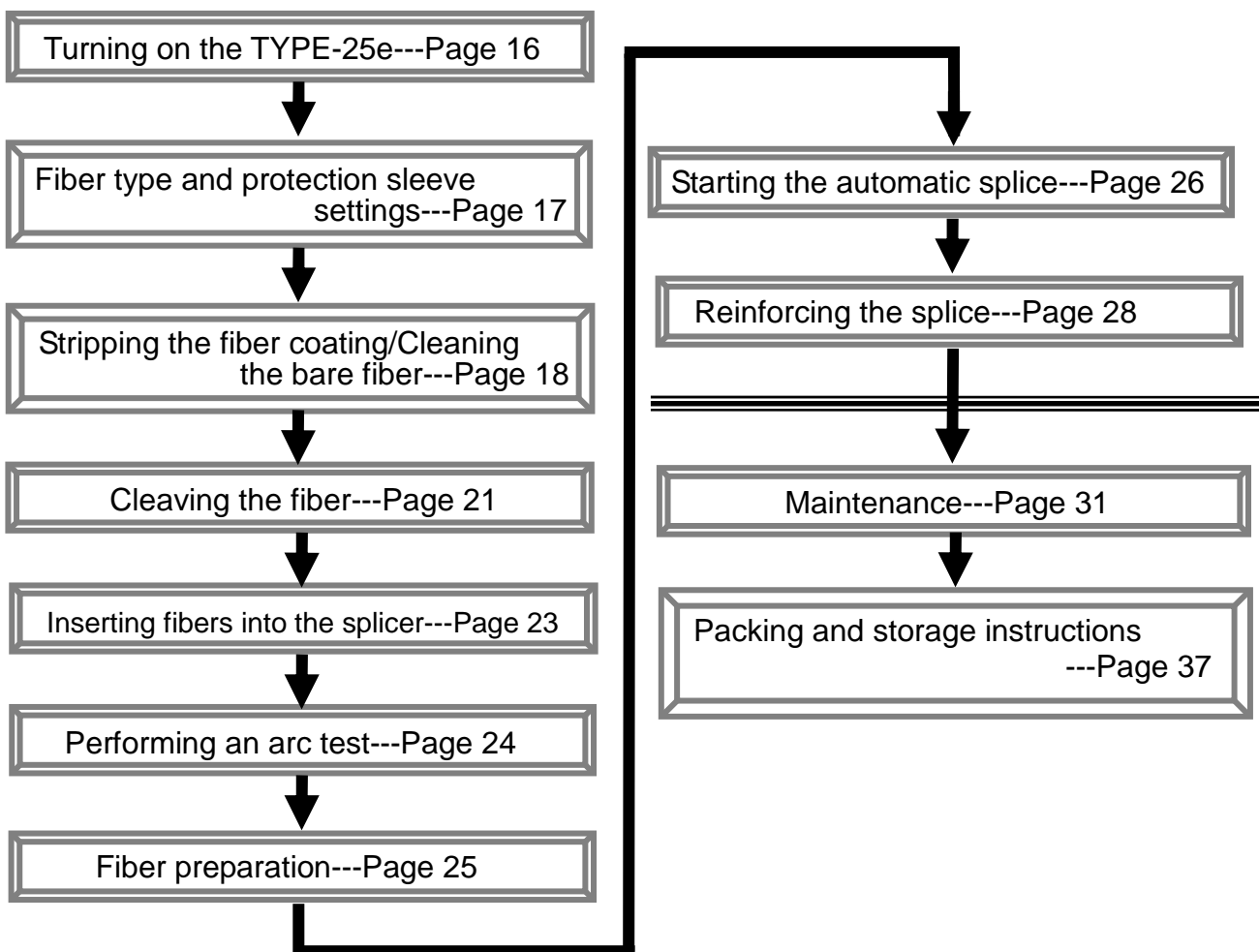

Preparing power

There are 2 power supply methods for TYPE-25e operation.

1. Battery operation, which is performed by means of the battery BU-25.
2. AC operation, which is performed by connecting the AC adapter ADC-1240 to the TYPE-25e.

Always use either of the above power supply methods. Failure to do so will damage the fusion splicer.

Battery opera-

The BU-25 is a rechargeable Lithium-Ion battery. You can recharge the battery before you have fully discharged it.

[Reference]

Splice cycles (splice + protection) per fully charged battery: Approx. 60 cycles
(Condition: Using an unused battery, 1 splice cycle shall be completed in 3 minutes in room temperature, without using a heated jacket remover.)

Using the battery in low temperatures may result in a decrease in splice cycles.

Inserting the bat-

Before inserting the battery, ensure that the battery is charged enough.



1. Open the bottom cover.



2. Install the battery as shown in the photo.



3. Close the bottom cover.



Caution

Note that the battery should be installed with a correct polarity.

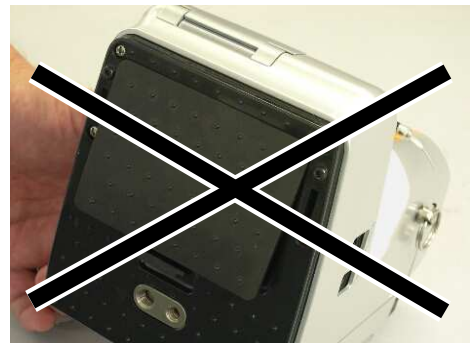

Caution

Be sure to close the cover completely.

Battery level

The battery level can be checked on the TYPE-25e monitor.



Indica-	Battery level
	Full
	Half
	Low
	No usable

Be sure to charge the battery before use when the battery level is low.

The battery level is not displayed on AC operation.

Charge the battery immediately.
The splicer is switched off 30 seconds after this indication appears.

Charging the bat-

<Using the TYPE-25e>

The battery BU-25 can be charged while installed in the TYPE-25e.



1. Insert the battery in the TYPE-25e.



2. Connect the AC adapter ADC-1240 to the splicer.



3. Charging starts and the battery charge LED on the keypad flashes.

4. Charging time is different depending on the remaining power in the battery. Typically charging is complete in approximately 3 hours. When charging is complete, the LED lights up.

LED status	Charging LED (red)
Lit	Charging is completed
Flashing	The BU-25 is being charged
Off	Battery faulty

<Using an optional battery charger>

The battery BU-25 also can be charged on the BC-25A, optional battery charger. The BC-25A is capable of charging 2 batteries simultaneously. Typically charging is complete in approximately 3 hours.



1. Place the battery charger BC-25A on a flat table.



2. Connect the AC adapter ADC-1635 to the BC-25A. (The Power LED lights up green.)



3. Insert the BU-25 into the battery compartment. The Charging LED flashes in red.



4. The Charging LED lights up red when the charge is completed.



5. Remove the battery from the battery charger and re-install it.

The BC-25A LED status indications are shown below.

LED status	Power LED (green)	Charging LED (red)
Lit	The BC-25A is powered on.	Charging is completed
Flashing	—	The BU-25 is being charged
Off	The BC-25A is powered off	Battery faulty



Warning

Charge the battery within a temperature range of 0 to 45°C. Failure to do so will decrease battery life and may cause battery leakage, heat generation, bursting and fire.



Caution

Only use the TYPE-25e or an optional battery charger (BC-25A) and an AC adapter (ADC-1635) to charge the battery. Failure to do so may cause a fire or electric shock.

Precautions for bat-

The battery can be recharged approximately 500 times under proper conditions of charging and discharging. However, the battery capacity might be significantly lowered, depending on the environment, the storage condition, or the charging environment. To maintain battery performance, fully understand the following handling of the battery before use.

- The battery is a consumable. Repeated charging and discharging decreases battery life. If you are getting fewer than splice cycles per fully charged battery, consider replacing the battery.
- Store the battery within the following temperature range. Failure to do so may lead to deterioration in performance.

	For less than 1 month	For less than 6 months
Storage temperature	0 to 45°C	0 to 25°C

- Do not use or store the battery at high temperature, such as in strong direct sunlight, in cars during hot weather. This may cause leakage of battery fluid.
- Before using the battery for the first time, charge the battery.
- When disposing of the battery correctly, please contact our maintenance service center or the local authority responsible for waste disposal in your area.

AC opera-



1. Connect the ADC-1240 AC adapter to the splicer.



- Tips** Plug the ADC-1240 into the DC input terminal.



When the AC adapter ADC-1240 is connected to the splicer in which a battery is installed and the power is ON, AC power supply is prioritized. (The battery is not used.) Battery charging starts when the power is OFF.



DC output power is available only when AC power is connected. (DC output power is not available when a battery is used.)



Caution

Do not plug the AC adapter ADC-1240 into the DC output terminal with a different diameter. Doing so may damage the splicer, causing heat or fire to occur.

Operating proce-

Turning on the

1. Preparing the power supply, referring to page 12-15.
2. Adjust the monitor for optimum viewing angles. (Please refer to “Monitor viewing angle” at page 45.
3. Press  key for more than 1 second to turn on the power.



<Initial screen>

After power up, the following screens are displayed.



Turn on the power.
→ Initialize screen



Initialization is complete.
→ Ready screen

Fiber type and protection sleeve set-

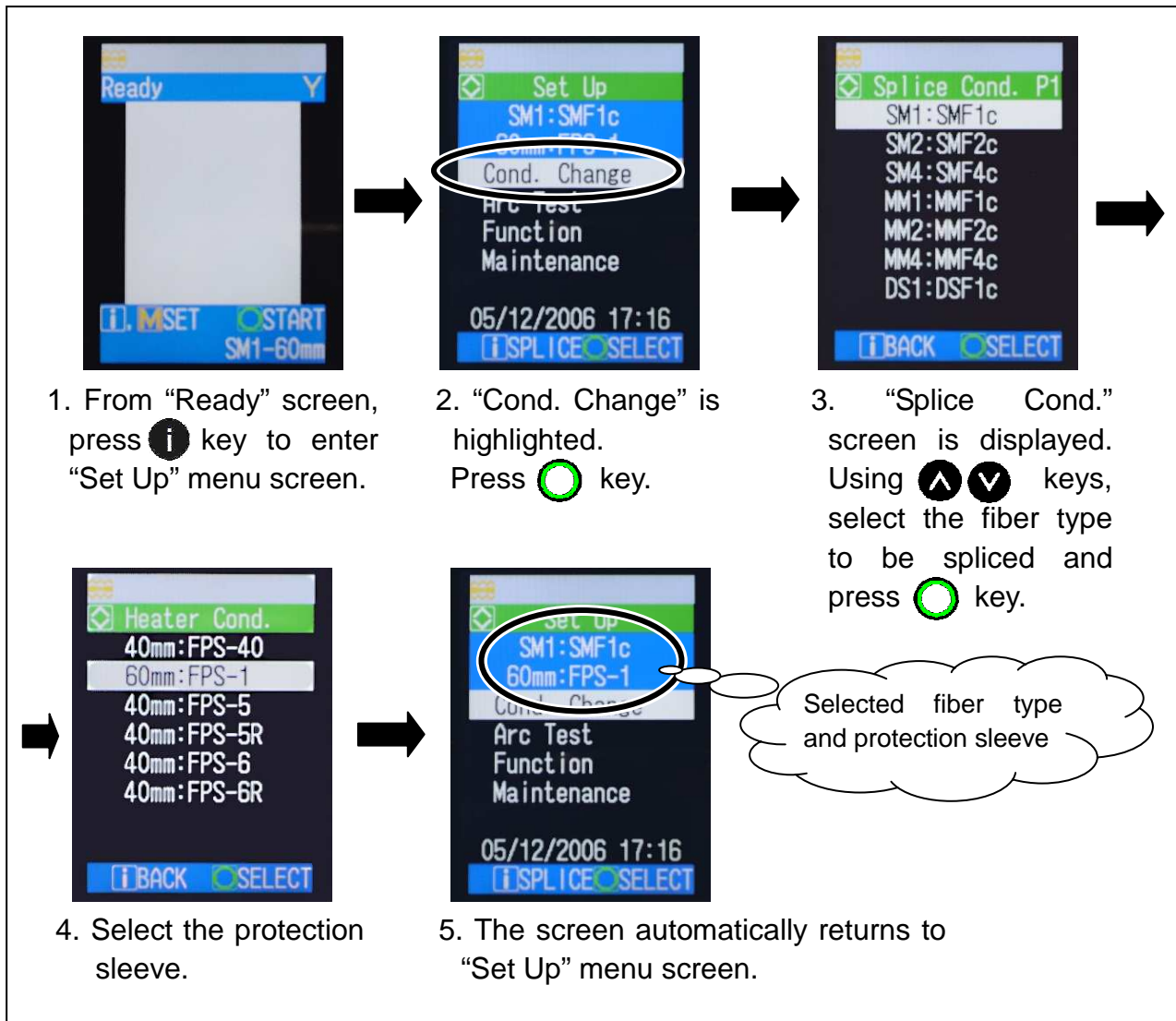

Refer to the tables below to select correct splice / heater conditions.

◆ Splice condi-

Fiber count	Single mode SM	Multi-mode MM	Dispersion shifted DS	Non-zero dispersion-shifted NZ-DS
1	SMF1c	MMF1c	DSF1c	NZ-DSF1c
2	SMF2c	MMF2c	DSF2c	NZ-DSF2c

◆ Heater condi-

Fiber protection sleeve type	Model	Condition	Remarks
Single fiber 40mm	FPS-40	40mm:FPS-40	
Single fiber 60mm	FPS-1	60mm:FPS-1	
Ribbon fiber 40mm	FPS-5	40mm:FPS-5	FPS-5 (Hi-speed)
		40mm:FPS-5R	FPS-5 and other equivalent sleeves
Ribbon fiber 40mm	FPS-6	40mm:FPS-6	FPS-6 (Hi-speed)
		40mm:FPS-6R	FPS-6 and other equivalent sleeves

Stripping the fiber coating / Cleaning the bare fiber

(If using the TYPE-25eM or TYPE-25eS)

This section describes the procedure of stripping the fiber coating, cleaning and placing the stripped fiber into the fiber holder.

Clean the fiber coating thoroughly to remove cable gel or other stains in advance.

For single fiber

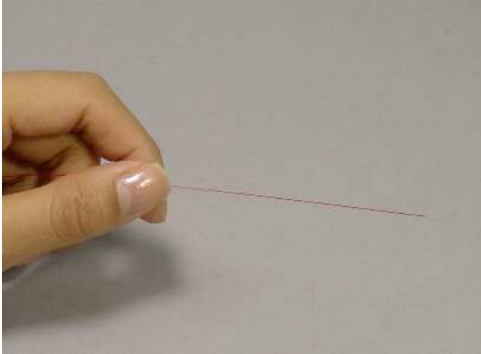

1. Prepare the fiber to be spliced.

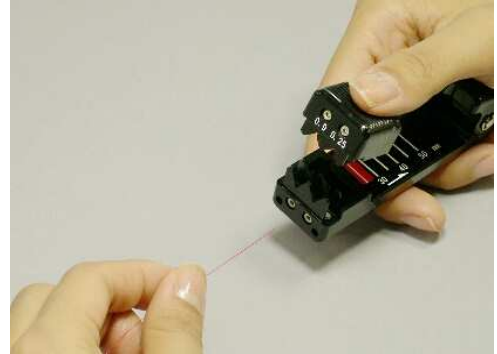

2. Strip 30-40 mm of the fiber coating with the JR-25 (ex).

(If you use another remover, please refer to its operation manual.)

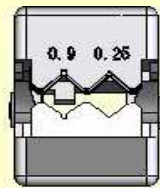

<1>: Check the fiber coating diameter.

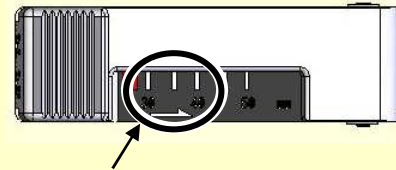

<2>: The end of the fiber coating at the 30-40mm mark on the ruler.

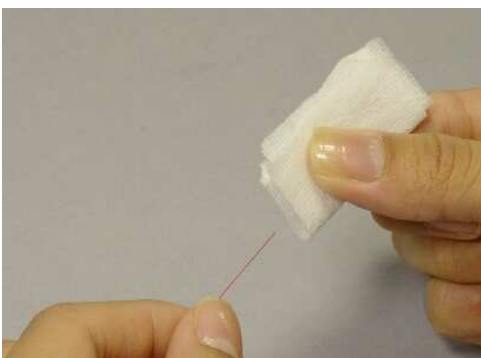

3. Clean the bare fiber with a lint-free gauze pad moistened with pure alcohol. Pull the bare fiber through the gauze pad. Rotate the fiber by 90 degrees to remove any coating residue. Do not reuse the gauze pad that was used.

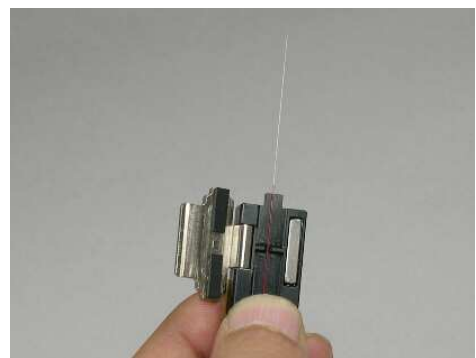

4. Place the fiber into the fiber holder. Ensure that 2-3 mm of the fiber coating protrudes from the edge of the fiber holder.



Keep the fiber squeaky clean.

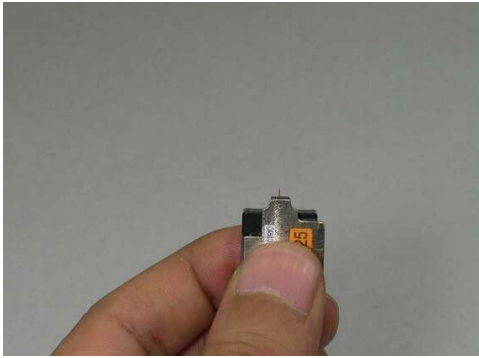

5. Repeat step 1 through 4 to prepare the other fiber.

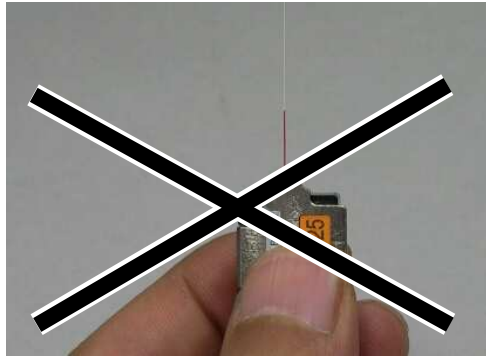

Caution

In step 4, if too much length of the fiber coating protrudes, the fiber coating will be loaded onto the clamp of the cleaver and the fiber cannot be cleaved properly.

For 4-fiber ribbon

In this operation manual the JR-5B jacket remover is used. Please read the JR-5B operation manual completely before use. (If you use another remover, please refer to its operation manual.)

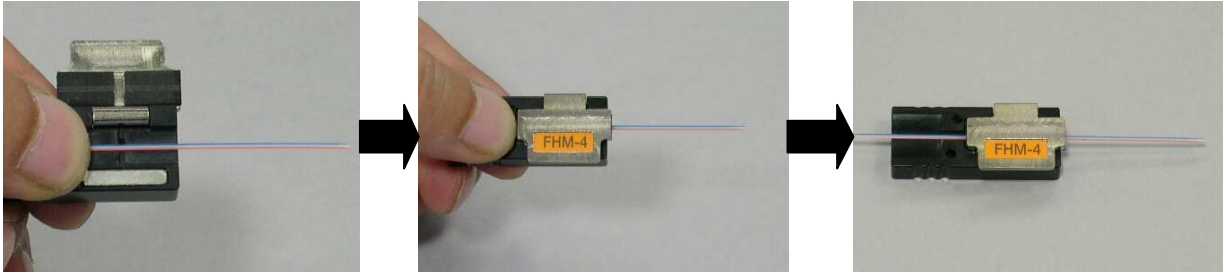

1. Place the fiber into the groove of the fiber holder, with 24~28mm of the fiber protruding from the holder and close the lid of the holder.

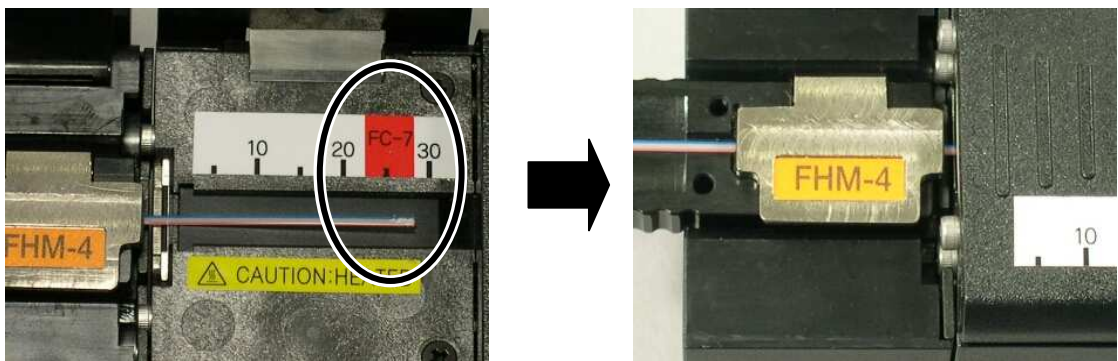

2. Place the fiber holder into the JR-5B.



Ensure that the coating end is positioned at "FC-7".

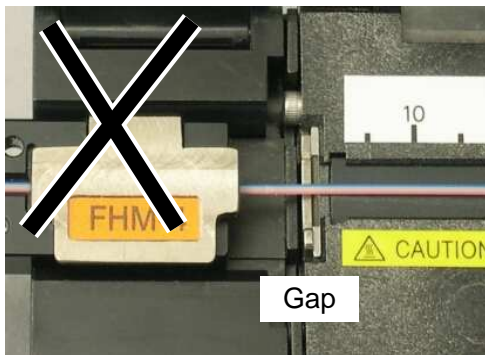

Touch the edge of the fiber holder against the JR-5B.

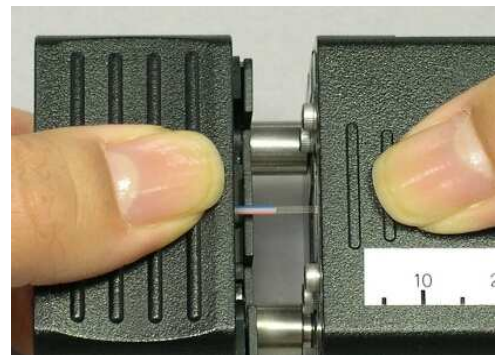

3. Strip the fiber coating according to the JR-5B operation manual.

Cleaving the fi-

(If using the TYPE-25eM or TYPE-25eS)

This section describes the procedure of cleaving the bare fiber.

In this operation manual, the FC-7 fiber cleaver is used. Please read the FC-7 operation manual completely before use. (If you use another fiber cleaver, please refer to its operation manual.)

***The cleave length is 10mm.**

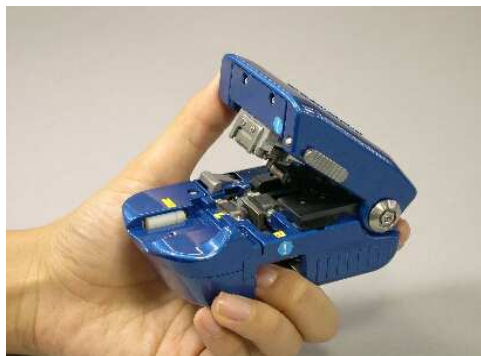

1. Press the slider until it is locked.



- The edge of the fiber holder should touch the edge of the fiber holder receptacle.
- The length of fiber off-cut to be collected is limited. The fiber cleaver may not store fiber off-cut with an improper length in the off-cut collector.

2. Place the fiber holder in the FC-7.



3. Press the cover. The slider will be moved.



Do not put your finger where the slider is moved.

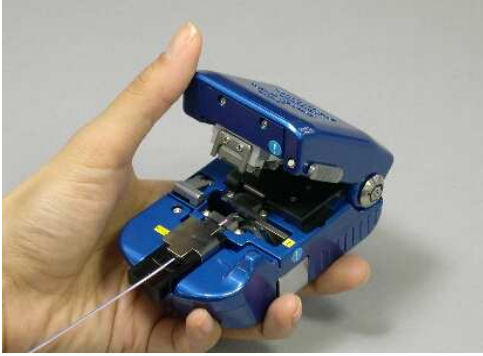

4. Open the cover.



5. Remove the fiber holder from the FC-7.



Caution

1. Do not re-clean the fiber after cleaving.
2. To avoid damaging or contaminating the delicate fiber ends, insert each fiber immediately after preparation.
3. Glass-fiber fragments are extremely sharp. Handle with care.

Inserting fibers into the

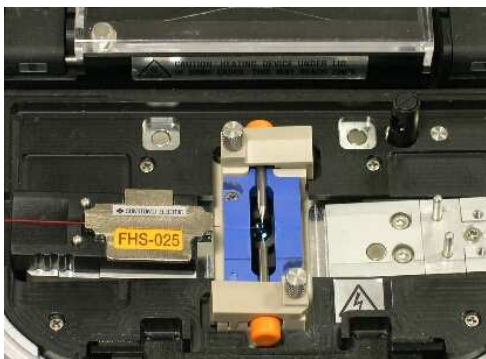

1. Open the hood and place the fiber holder onto the receptacle.

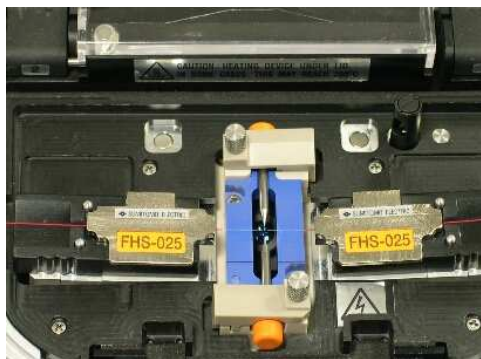

2. Place the other fiber holder in the same way.



3. Close the hood.



Tips

After fitting the pin of the receptacle into the hole of the fiber holder, lower the edge of the fiber holder down onto the V-groove.

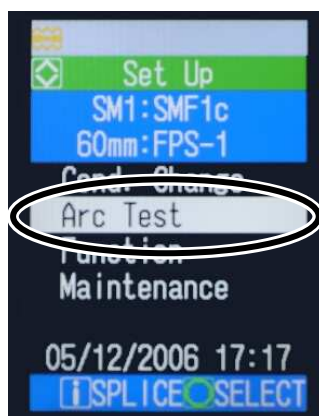

4. From "Ready" screen, press **i** key to enter "Set Up" menu screen. Please read the next page to perform an arc test.

Performing an arc

The fusion splicer has a built-in Arc test feature that should be used to ensure consistent high-quality splices with low splice losses. Performing an arc test automatically adjusts the arc power and position to compensate for environmental conditions, electrode wear and the melting characteristics of the fiber types in use.

Situations that should prompt an arc test are:

- Initial splicing set-up
- Changing fiber types
- Extreme changes in temperatures, humidity or air pressure
- Poor splice performance
- After electrode replacement

1. Check to see if the displayed fiber type and protection sleeve type are correct. (If not, change the settings referring to page 39.) Select “Arc test”.

2. After ensuring the screen has been switched to “Arc Test Ready” screen, press  key to start an arc test.

3. Arc is generated. (Fibers are not spliced.)

4. If “Arc OK” is displayed, begin the fiber preparation procedure to perform a splice. The splicer automatically initializes when the hood is opened.

Caution

If “Arc Too Weak”, “Arc Too Strong” or “Arc Center” is displayed, prepare the fiber again and repeat the test until “ARC OK” is displayed.

Arc test result

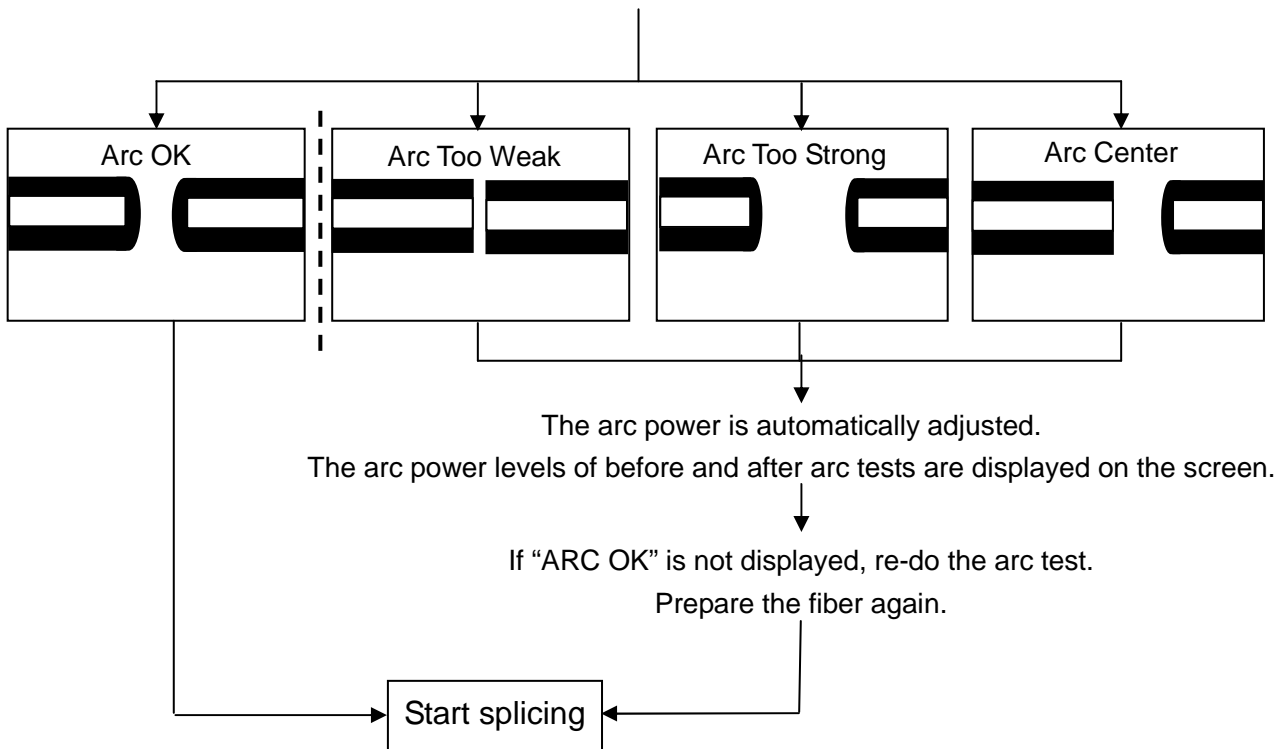

The adjusted arc power level is stored even if the splicer is turned off.

Fiber preparation

Be sure to slip the fiber protection sleeve over one of the fibers to be spliced before stripping and cleaving the fibers. The fiber protection sleeve cannot be installed after splicing.



1. Prepare the fiber protection sleeve suitable for the fiber to be spliced.

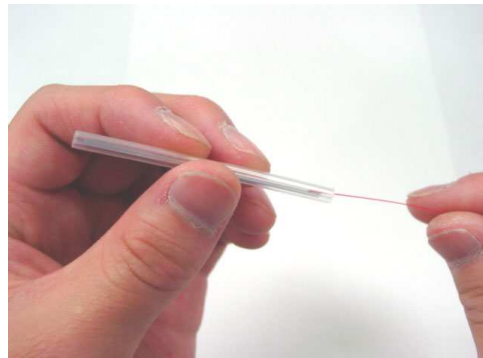

2. Slip the fiber protection sleeve over the fiber.

3. Strip the fiber coating and clean the bare fiber. Refer to page 18-20.

4. Cleave the bare fiber to proper cleave length. Refer to page 21-22.

5. Insert the fiber into the splicer Press  key to start the automatic splicing process.

Starting the automatic



1. From "Ready" screen, press **START** key to start the splicing process.



2. The prefusion check is done and then arc is generated.



3. After fibers are spliced, estimated splice loss is displayed.

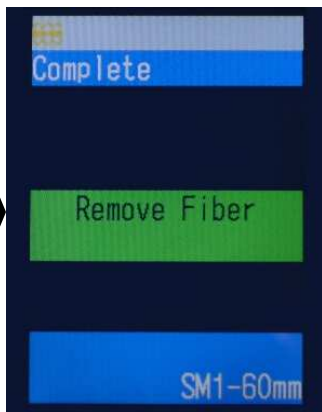

4. Open the hood. The proof test is automatically started. After "Remove fiber" appears on the screen, remove the spliced fiber from the fiber holder.

• To view splice data, press **i** key.



• To perform re-arc, press **M** key.

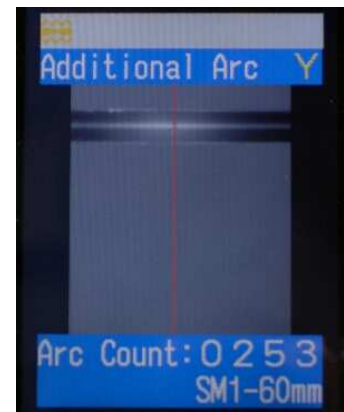

• If an error messages is displayed on the screen during splicing, press **i** key. A troubleshooting message will appear. (Also refer to "Error message list" at page 48-50.)



Caution

Take care to keep the spliced fiber straight. Do not flex it back and forth. Doing so will cause the spliced fiber to be broken, resulting in loss of the long term reliability of the fiber.

Evaluating splice quality

If the spliced fiber is as follows or estimated losses are high, re-do the entire splice.

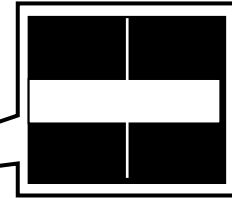
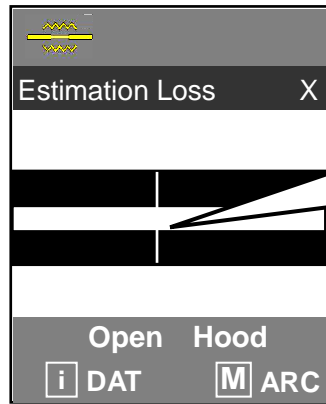

White line
(Re-arc→NG→
Re-do splicing.)

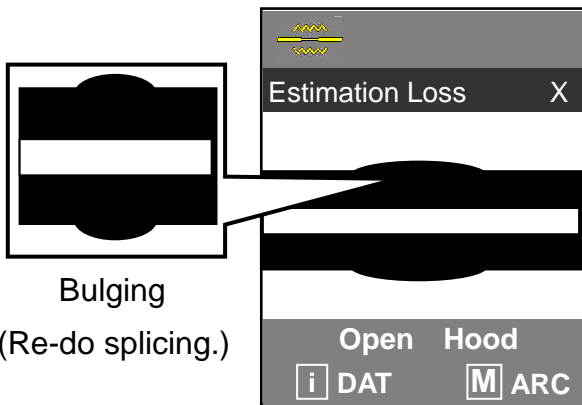

Bulging
(Re-do splicing.)

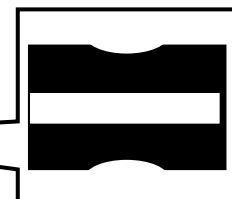
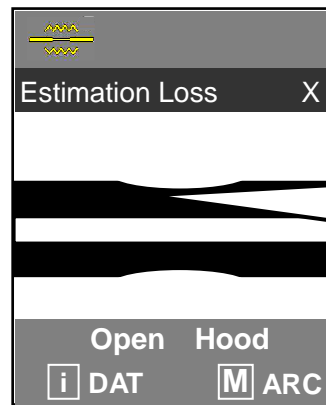

Neck-down
(Re-do splicing.)

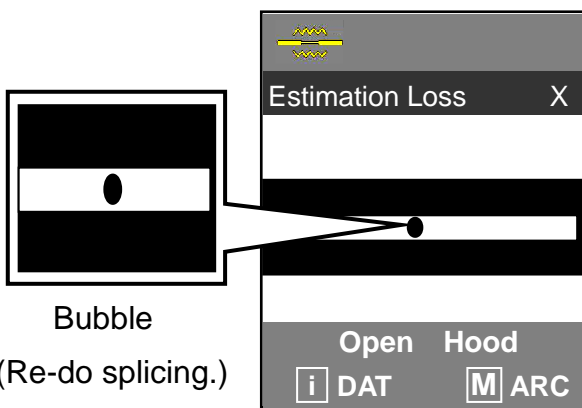

Bubble
(Re-do splicing.)

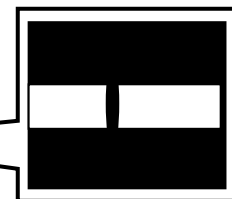
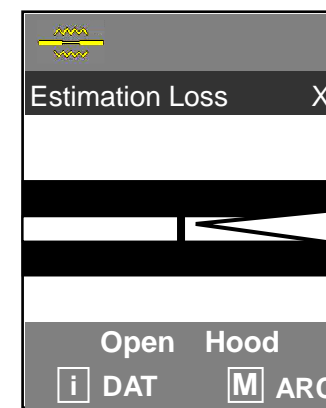

Black line
(Re-do splicing.)

Reinforcing the splice

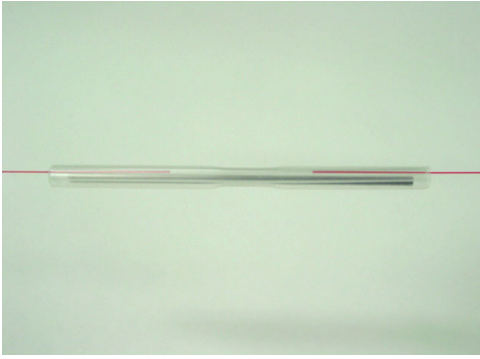

1. Slide the sleeve over the spliced portion.

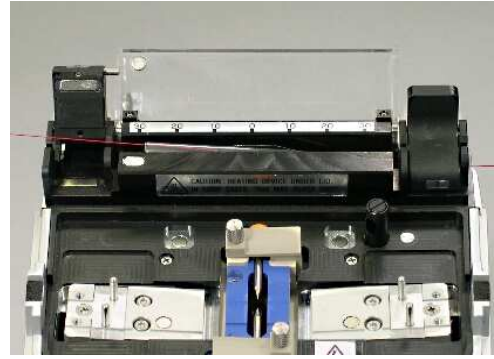

2. Lower the fiber onto the right clamp arm and push down.

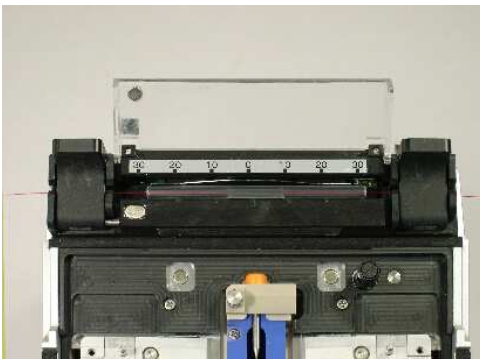

3. Lower the fiber onto the left clamp arm and push down while pulling the fiber.

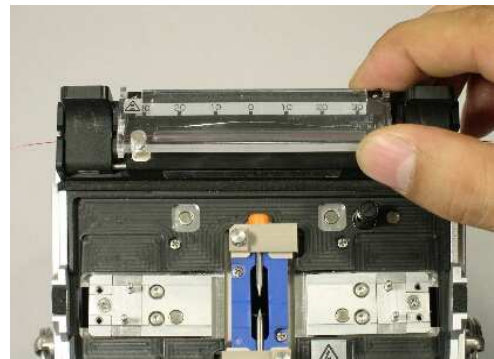

4. Close the acrylic lid.

- Ensure that the fiber protection sleeve is centered over the splice.
- Ensure that the fiber protection sleeve is centered on the heat shrink oven.



5. Press  key to start the heating cycle.



6. A beep sounds when the heating process is completed.



Caution

- A protection sleeve is hot after heating and may cause personal injury if touched.
- Never touch the heat shrink oven during heating. Doing so may cause personal injury or damage the heat shrink oven.

Heating cycle status indicator bar

The heating cycle indicator bar enables checking the progress of the heat cycle on a monitor.

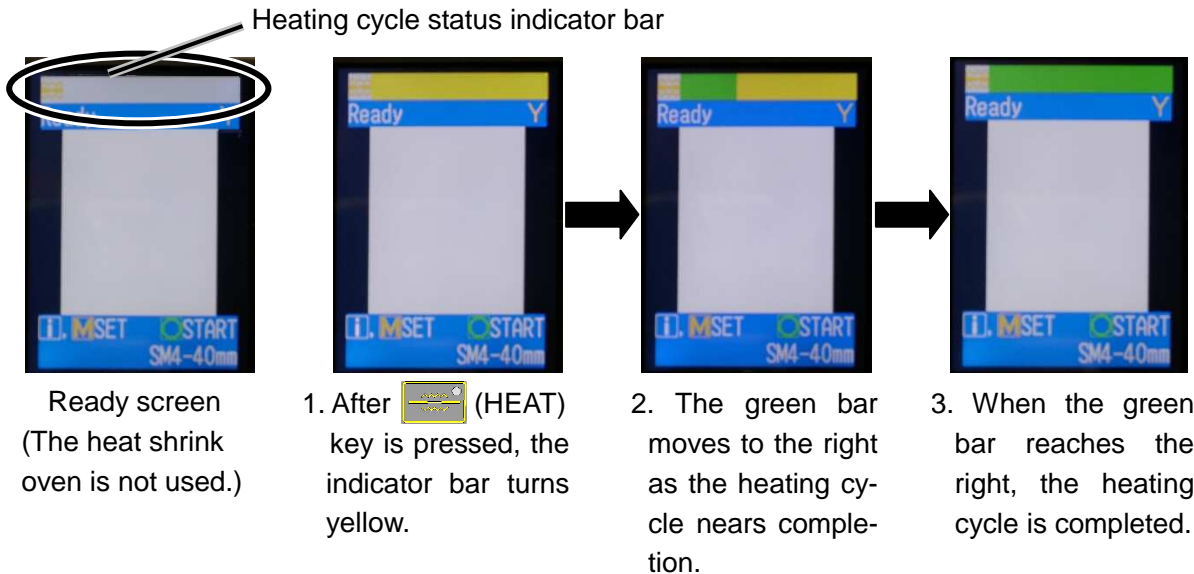

Evaluating protection sleeve

OK

Completely shrunk, no bubbles, the splice is centered in a sleeve



NG

1: The shrinking sleeve is not centered over the splice.



2: Bend in bare fiber



3: Bubbles on bare fiber



Using cooling tray



1. Tighten the fixing screws halfway.



2. Insert the cooling tray.



3. Tighten the screws completely to secure the tray to the splicer.



Caution

Check that the cooling tray is fixed properly.

3. Maintenance

To keep excellent splice quality, regular cleaning and inspection are required. Especially cleaning should be performed before and after each use. We recommend your splicer to be checked through our maintenance service once a year.



Warning

Turn off the TYPE-25e before maintenance work. Failure to do so may cause electric shock.

Cleaning

Clean each part with a V-groove cleaning brush or a cotton swab. Please bear in mind that daily cleaning can maintain splicer performance.

Cleaning the V-grooves

Even tiny bits of dust or dirt in the V-grooves might cause the fiber to be offset. To avoid offset, carefully clean the V-grooves with a V-groove cleaning brush or a cotton swab moistened with alcohol.



1. Prepare a V-groove cleaning brush or a cotton swab moistened with alcohol.

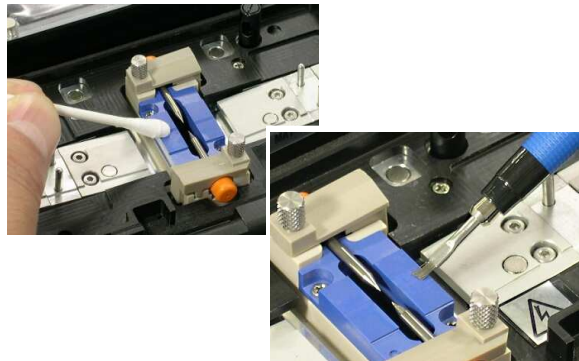

2. Brush the surface of the V-grooves.

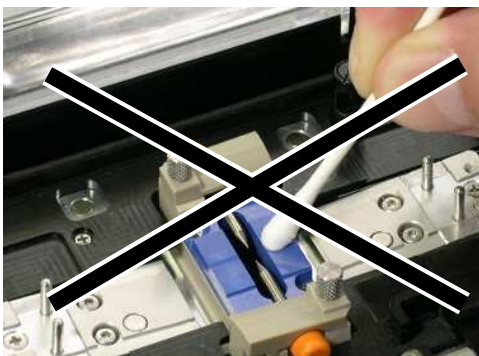

Caution

Do not apply too much force when cleaning.

Please refer to the appendix in the end of this manual for handling of a V-groove cleaning brush.

Cleaning LEDs

When a LED is dirty, the fiber image is unclear, resulting in imperfect image processing. If the display is uneven or LED error occurs, clean the LED.



1. Prepare a cotton swab moistened with alcohol.

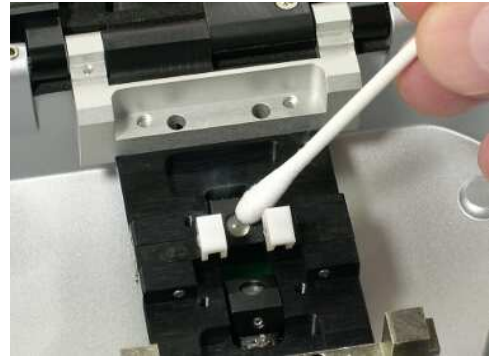

2. Gently wipe the surface of the LED.

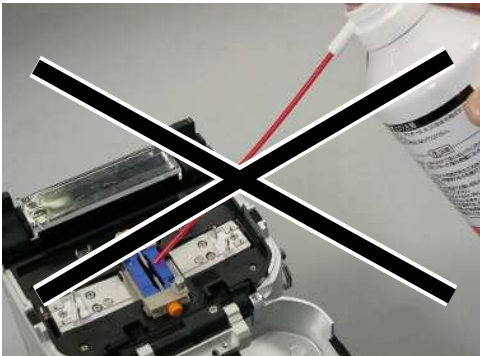

Do not use a canned air for cleaning. Doing so will contaminate the LED.

Cleaning bare fiber pads

Dirt on a bare fiber pad will also cause the fiber to be offset. When fiber offset occurs, clean the bare fiber pads.

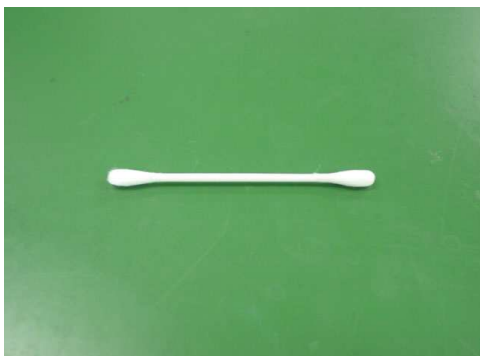

1. Prepare a cotton swab moistened with alcohol.

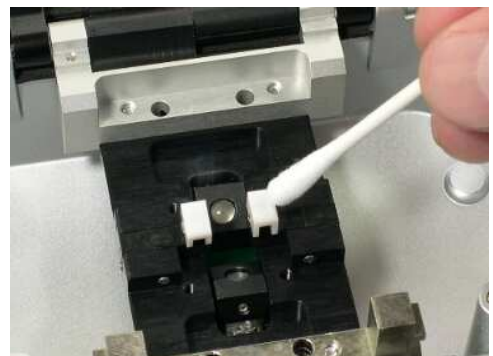

2. Clean the surface of the bare fiber pads.



Do not apply too much force when cleaning.

Cleaning micro-

If an unclear fiber image is displayed or LED error occurs again after cleaning LEDs, clean the microscopes.

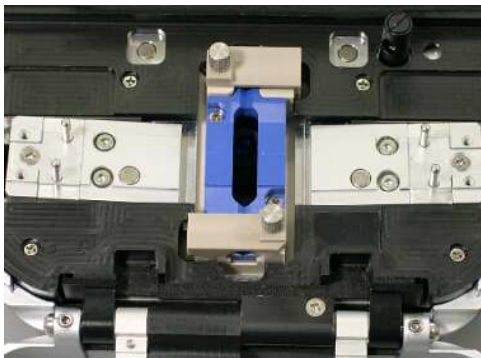

1. Remove the electrodes, referring to the next section.

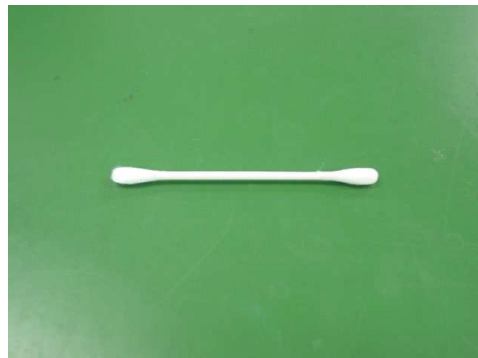

2. Prepare a cotton swab moistened with alcohol.



3. Gently wipe the lens of the microscope in a circular motion.

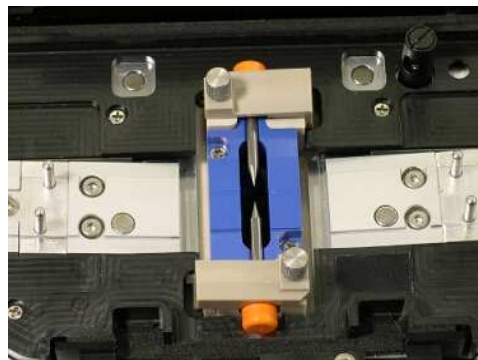

4. Refit the electrodes.

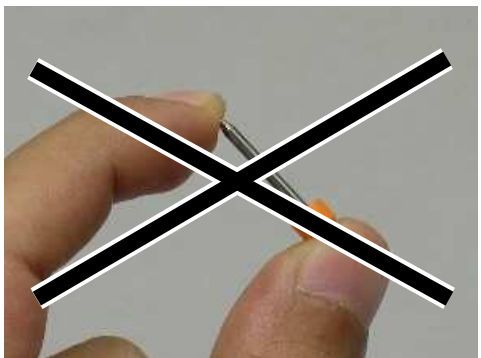

An electrode tip is extremely sharp. Handle with care.

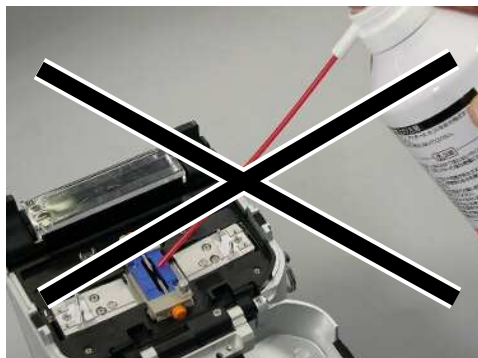

Do not use a canned air for cleaning. Doing so will contaminate the lens.

Cleaning other compo-

Dirt or dust can accumulate in the clamping areas of the fiber holder and the heat shrink oven. Clean them thoroughly.



Clean the fiber holder with a cotton swab moistened with alcohol.



Clean the heat shrink oven with a dry cotton swab.



Remove moisture or alcohol on the heat shrink oven with a dry cotton swab.

Replacing the elec-

After 1000 discharges, arc count indication turns red during arcing. To maintain fusion splicer quality, replace the electrodes after approximately 1000 discharges. An electrode tip is extremely sharp. Handle with care.



1. Turn off the splicer.



2. Using your fingers, loosen the thumbscrew.



3. Remove the electrode cover plate.



4. Remove the old electrode.



5. Install a new electrode. Tighten the thumbscrew while pushing the plastic button against the electrode cover plate.

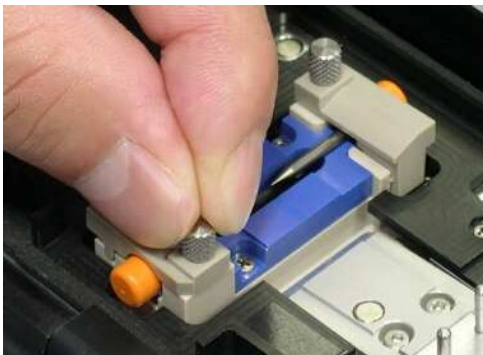

6. Repeat Step 2 to 5 for the other electrode. Always replace both electrodes at a time.
7. Turn on the power and condition the electrodes. (Refer to page 44.)



Caution

An electrode tip is extremely sharp. When handling the electrodes, avoid touching the electrode tips with anything.

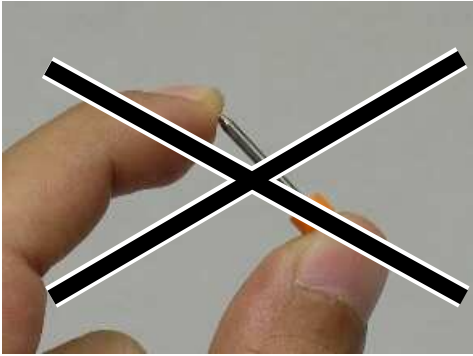

An electrode tip is extremely sharp. Handle with care.

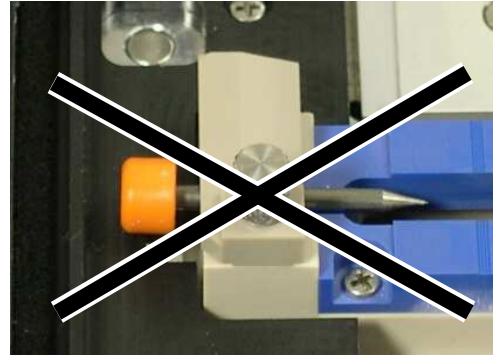

Ensure that the new electrode is fully inserted with the plastic button against the cover plate.



Caution

- Be sure to turn off the splicer and unplug the power cord or remove the battery before replacing the electrodes.
- Discard the old electrodes properly.

Only use original Sumitomo electrodes to achieve desired arcing performance.

Packing and storage instruc-

- Store the TYPE-25e and its accessories in a designated place in the case referring to the photo below.
- Store the splicer in the direction shown in the photo below.
- Before storing the splicer in the carrying case, remove the cooling tray.

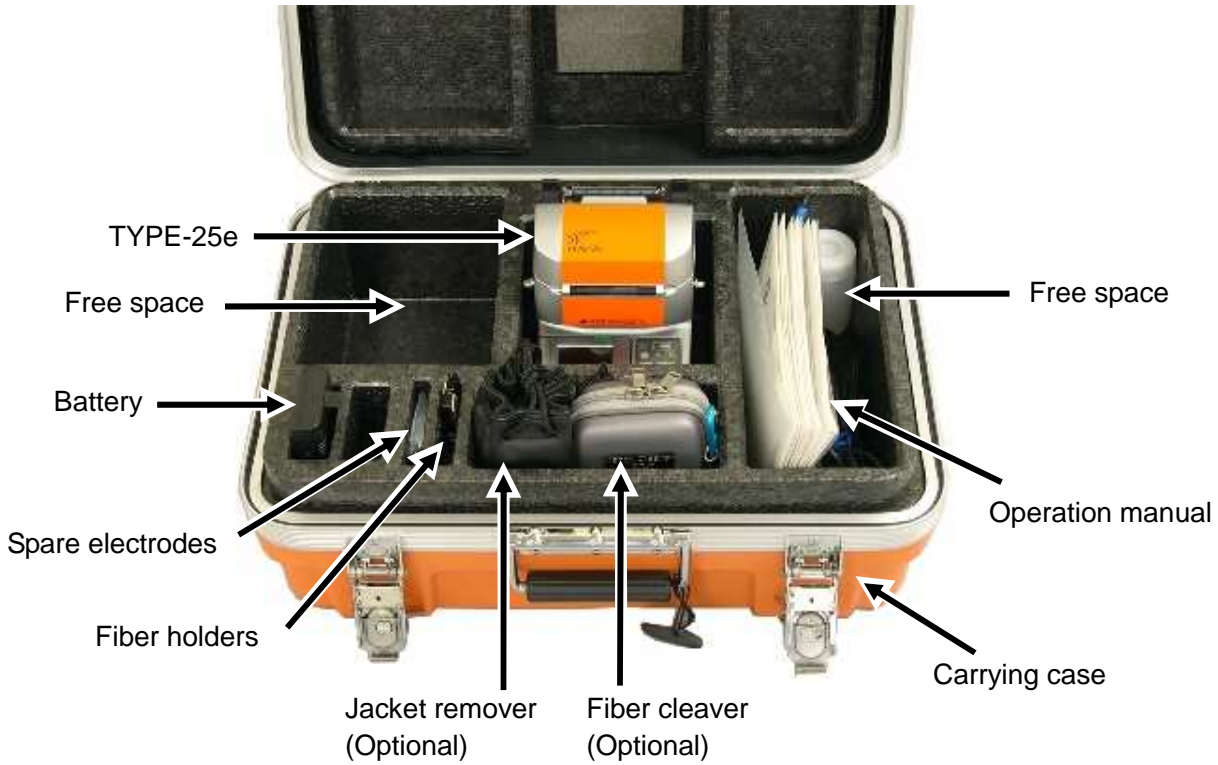

The TYPE-25e fusion splicer is a precision instrument. Its rugged shipping/ storage case is custom designed to protect it from impact, dust, dirt, and moisture. Always store and transport the machine in its case. Observe the following instructions.

- Clean the TYPE-25e, the fiber holders and other accessories before storing them.
- Be sure to remove the battery from the TYPE-25e and store it in place.

 **Warning** Keeping the battery in the TYPE-25e may cause the battery to be damaged or deteriorated, resulting in fire. Remove the battery from the TYPE-25e before storage.

 **Caution** Transporting the TYPE-25e with the fiber holders loaded may cause the V-grooves or clamps to be damaged, resulting in the failure of splice. Remove the fiber holders from the TYPE-25e before storage.

- Reposition the monitor before storing. (Refer to page 45.)
- Discard the liquid solvent properly, or lock the dispenser completely and put it in a plastic bag before packing the dispenser in the case.



Warning

Handle alcohol with extreme care. Alcohol is flammable.

- Before storing the fiber cleaver, dispose of the fiber fragments collected in the off-cut collector in a proper way.



Caution

Glass fiber fragments are extremely sharp. Handle with care.

- Pay attention to storage temperature and dew condensation when storing the splicer.
Storage temperature -40°C ~ +70°C

4. Functions

The TYPE-25e is provided with various functions. Make function settings depending on how you use.

Fiber type and protection sleeve set-



1. From "Ready" screen, press **i** key to enter "Set Up" menu screen.

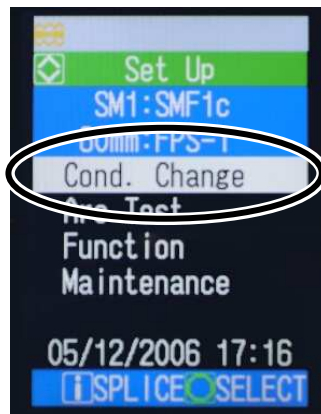

2. "Cond. Change" is highlighted. Press **o** key.



3. "Splice Cond." screen is displayed. Using **▲** **▼** keys, select the fiber type to be spliced and press **o** key.



4. "Heater Cond." screen is displayed. Using **▲** **▼** keys, select the protection sleeve type and press **o** key.

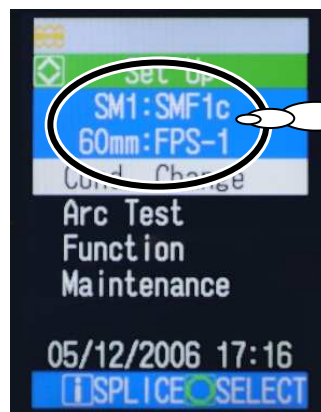

5. The screen automatically returns to "Set Up" menu screen.

Tips Press **i** key to go back to the previous screen.

Changing splice and heating condi-



1. From "Ready" screen, press **M** key to enter "Cond. Change" screen.

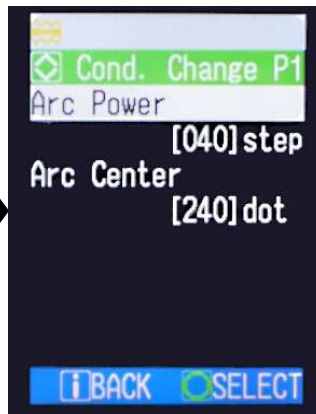

(Page 1)

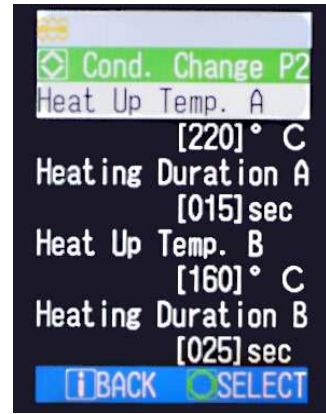

(Page 2)



(Page 3)

2. Using **▲** **▼** keys, highlight the condition you would like to change. Press **○** key.

Tips

- Press **M** key to go to the next page.
- Press **i** key to go back to "Ready" screen.

<How to enter numeric values>

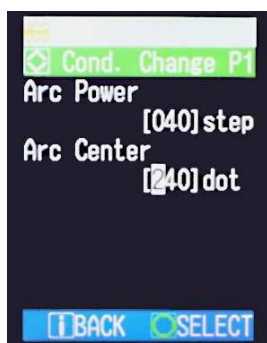

1. After selecting the condition (function) and pressing **○** key, the leftmost digit is highlighted and active. Using **▲** **▼** keys, increase/decrease the digit to a desired value.

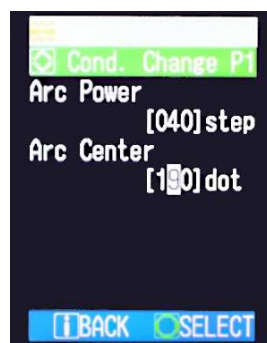

2. Press **○** key to advance to the next digit. Repeat Step 1 & 2 until the last digit is entered.

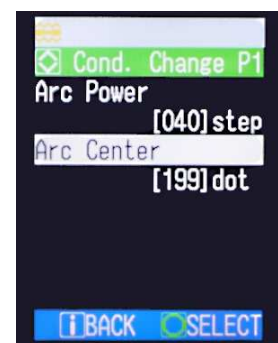

3. When the last digit is entered, press **○** key. A new value is set.

Splice condition settings	
Fusion Time (seconds)	Fusion time is the duration of arc discharge.
Prefusion Time (seconds)	Pre-fusion time is the time in seconds the fiber ends wait after the arc discharge begins before beginning the overlap (feed).
Arc Gap (micrometers, μm)	Arc gap is the distance between the left and right fibers before fusion takes place.
Over Lap (micrometers, μm)	Over lap is the amount of over lap between the left and right fibers that occurs when the right fiber is fed forward during the arc fusion.
Arc Power (Step)	Expressed in a unitless step value, arc power controls the amount of heat the fibers are exposed to during the fusion arc.

Heating condition settings	
Heat Up Temperature A ($^{\circ}\text{C}/^{\circ}\text{F}$)	Center area starts raising up to the set temperature.
Heating duration A (seconds)	After heat shrink oven reaches Heat Up Temperature, it maintains the temperature of center area for this duration.
Heat Up Temperature B ($^{\circ}\text{C}/^{\circ}\text{F}$)	Both ends start raising up to the set temperature.
Heating duration B (seconds)	After heat shrink oven reaches Heat Up Temperature, it maintains the temperature of both ends for this duration.



1. From "Ready" screen, press **i** key to enter "Set Up" screen.



2. From "Set Up" menu screen, using **▲ ▼** keys, highlight "Function". Press **○** key.

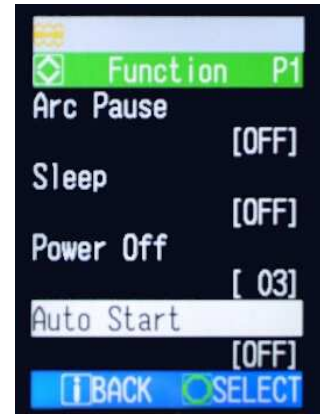

3. Using **▲ ▼** keys, highlight the function you would like to change. Press **○** key.

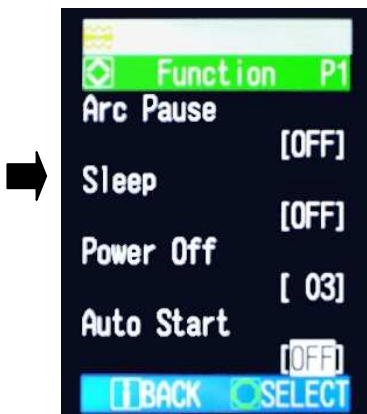

4. The current setting is highlighted. Using **▲ ▼** keys, change the setting. Press **○** key to accept the change.

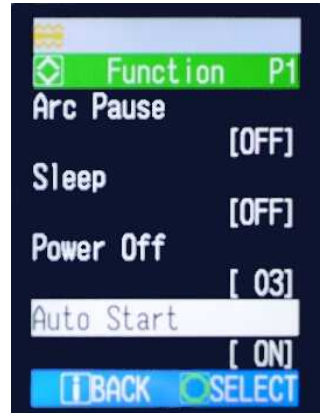
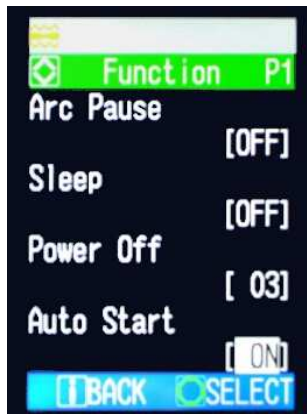

Tips

- Press **M** key to go to the next page.
- Press **i** key to go back to "Ready" screen.

Please refer to page 40, regarding how to enter numeric values.

Functions

<Arc pause>

This function stops the splicing process before arcing occurs. If you would like to check offset and fiber end-faces, set this function to ON.

<Sleep>

If the splicer is not interrupted for a certain span of time, to minimize power consumption on standby, the camera and the LED are powered off. The splicer can be re-activated by pressing any key except OFF.

<Power off>

If the splicer is in Sleep mode and is not interrupted for another certain span of time, the splicer is automatically powered off. You need to switch on the splicer again.

<Auto start>

This function automatically starts the splice process when the hood is closed.

<Memory>

This function stores splice data such as cleave angle, offset and so on.

<Display>

This function displays stored splice data by designating the splice data number.

<Output>

This function downloads stored splice data to a PC. Contact maintenance service center if you would like to use this function.

<Clear>

Data of a maximum of 1500 splices can be stored. After data of 1500 splices are stored, the oldest splice data is deleted and the latest splice data is stored. This function deletes all the stored data at a time.

<Light for V-groove>

This function sets the V-groove illumination to ON or OFF.

<Date>

This function sets the built-in clock of the splicer to local time.

<Language>

This function selects display language.

<Temperature Unit>

This function switches the temperature units.

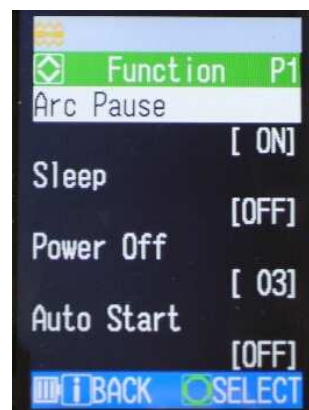

Maintenance func-



1. From "Ready" screen, press **i** key to enter "Set Up" screen.



2. From "Set Up" menu screen, using **▲** **▼** keys, highlight "Maintenance".
Press **○** (SELECT) key.

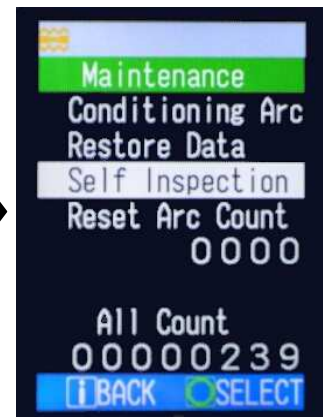

3. Using **▲** **▼** keys, highlight the function you would like to start it.
Press **○** (SELECT) key.

Tips

- Press **i** key to go back to "Ready" screen.

<Conditioning arc>

After the electrode is replaced, this function is used to condition a new electrode. Refer to page 35 as to electrode replacement.

<Restore data>

All parameters except for arc count and total arc count are returned to the factory setting.

<Self inspection>

Use this function if an error occurs repeatedly. If all results are not "Good", please contact our maintenance service center.

<Arc count reset>

After replacing the electrodes, reset the arc count. The number of the arc discharge with electrodes can be checked.

<Total arc count>

This function checks total arc counts on the splicer. The total arc count can never be reset.



Monitor viewing an-

Monitor viewing angle is adjustable. However, do not force the monitor over the maximum angle. Adjust the angle within the allowable range until you can clearly see an image.

* The monitor cannot be fixed if the monitor is angled at a small angle.

* Low temperature will give a darker image. This is the characteristics of LCD monitor, not a defective.



1. Standard
(Storage position)



2. Halfway



3. Maximum



Caution

Do not apply too much force when adjusting the monitor angle.

Special note on monitors

Although bright spots or dark spots may appear on the screen, this is a unique characteristic of liquid crystal displays, and such do not constitute or imply a machine defect.

Using neck

Neck strap enables hanging the splicer around an operator's neck. Use the ring for hook on the splicer according to the operational environment.



Caution

- Ensure that the strap should be attached to the rings.
- Whenever you use the rings, be sure to hold the splicer with your hand. Failure to do so will cause the splicer to turn over and accessories such as fiber holder will drop.

Tripod fixing

The TYPE-25e has a screw hole for a tripod on their bottom.



Tripod fixing screw



Attach a tripod to the splicer

5. Troubleshooting

For repair and technical support, please contact our maintenance service center address described in the back cover.

Arc Problems

The electrodes typically need replacing after 1000 splices. Some common symptoms that indicates the electrodes need replacing are:

- Fluttering or unstable arc observed on the monitor
- Sizzling noise while arcing
- Bubbles in the fibers after splicing
- Fiber burned in half
- High or inconsistent splice losses

Refer to page 35-36, “Replacing electrodes” for procedures.

Hitting or handling the electrode tip with bare fingers would deform the electrode, resulting in poor arcing quality.

Fiber breaking

When the splicing process is complete, a proof test may be performed on the fibers. If the fibers are breaking when the proof test is performed, re-do an arc test. If the arc power level is too weak, the splice may be poor, resulting in fiber breaking.

If the fibers are breaking in spite of a good arc test result, clean the V-grooves and the bare fiber pads completely. Deterioration of a jacket remover/fiber cleaver may lead to fiber breaking. Clean the jacket remover/fiber cleaver completely.

Splicer does not power

If the fusion splicer fails to turn on when the ON key is pressed, check the following:

- Verify that the power supply module or battery module is installed in the module bay properly
- Verify that the power plug is seated properly (the power cord is connected to the power supply module.)
- Verify that the LED of the power supply module lights up.
- If using battery operation, ensure that the battery module is fully charged.

If the splicer still does not power up after checking the above, contact our maintenance service center.

Error message List

Please contact our maintenance service center when it is not recovered if you take the measures below:

Error message	Description and measure
Brightness var. err Brightness error LED error	[Description] The splicer failed in the brightness adjustment of the illumination LED. [Measure] (1) Clean the illumination LED in the hood. (2) Clean the lens of the microscope. * If this error repeatedly occurs, please contact us.
Hood open error	[Description] The hood is not closed completely. [Measure] (1) Close the hood completely. * If this error repeatedly occurs, please contact us.
Insert fiber error	[Description] The splicer failed to insert the fibers within the drive time limit. [Measure] (1) Place the fiber holders properly. (2) Load the fiber into the fiber holder properly.
Cut err (proj.)	[Description] The splicer detected projection in an end-face inspection [Measure] (1) Cleave the fiber again. (2) Clean the upper and lower rubbers of the clamps of the cleaver. (3) The blade of the cleaver might be deteriorated. Change the blade height or replace the blade.
Fiber check err	[Description] The fiber is not placed in the V-groove [Measure] (1) Place the fibers into the V-grooves again. (2) Clean the V-grooves with a V-groove cleaning brush.
Fiber count err Fiber pitch err	[Description] The fiber count is different from the setting or the fiber pitch is large. [Measure] (1) Place the fibers into the V-groove again. (2) Set the correct fiber count to be spliced.

Error message	Description and measure
Irregularity err Gap error	<p>[Description] The irregularity of the fiber end face positions exceeds the allowable level.</p> <p>[Measure] (1) Cleave the fiber again. (2) Clean the upper and lower rubbers of the clamps of the cleaver. (3) The blade of the cleaver might be deteriorated. Change the blade height or replace the blade.</p>
Cut err (crack)	<p>[Description] The splicer detected the crack on the fiber end face.</p> <p>[Measure] (1) Cleave the fiber again. (2) Clean the upper and lower rubbers of the clamps of the cleaver. (3) The blade of the cleaver might be deteriorated. Change the blade height or replace the blade.</p>
Cut err (angle) Cut error (lip)	<p>[Description] The cleave angle exceeds the allowable level.</p> <p>[Measure] (1) Cleave the fiber again. (2) Clean the upper and lower rubbers of the clamps of the cleaver. (3) The blade of the cleaver might be deteriorated. Change the blade height or replace the blade.</p>
Alignment error	<p>[Description] The core offset exceeds the allowable level.</p> <p>[Measure] (1) Place the fibers into the V-groove again. (2) Clean the V-grooves with a V-groove cleaning brush. (3) Clean the fiber clamps with a cotton swab. (4) Clean the stage and fiber holders with a cotton swab.</p>
Splice error Thin error Thick error Bubble error	<p>[Description] There is an unusual problem with the spliced point.</p> <p>[Measure] (1) Adjust the arc power in arc test. (2) When the Irregularity is large, clean the fiber cleaver.</p> <ul style="list-style-type: none"> • Thin: 1) The fiber irregularity is large. 2) The arc power is strong. • Thick: 1) The fiber irregularity is large. 2) The arc power is weak. • Bubble: The fiber irregularity or the cleaving condition on the fiber end-face is poor.

Error message	Description and measure
Splice error Thin error Thick error Bubble error	* Unusual splice is performed due to the abnormality of the fiber cleaver as well as the splicer. Perform a regular maintenance on the fiber cleaver in the same manner as the splicer.
End check error Diam. check err Dust error Image pro. err	[Description] The splicer failed in the image processing due to dust on the fiber [Measure] (1) Clean the bare glass after removing the fiber coating. (2) Cleave the fiber again. (3) Clean the illumination LED in the hood.
Device error System abort Exception Error	[Description] The system error occurred. [Measure] (1) Turn off the splicer and turn it on again. * If this error repeatedly occurs, please contact us.

Product Specifications

The specification is different depending on the model. Please check the specification in this section.

Item	TYPE-25eM	TYPE-25eS	TYPE-25eS-LC	
Optical fiber requirements				
Material	Silica glass			
Profile type	SMF, MMF, DSF, NZDSF			
Fiber diameter	125μm			
Fiber coating diameter	0.25mm, 0.5mm, 0.9mm	0.25mm	0.9mm tight-buffer	0.9mm loose-buffer
Cleave length	10mm	10mm	10mm	Total 20-22mm (10mm of bare)
Fiber count	1, 2, 4	1		
Size and weight				
Size (Main body)	120(W) x 145(D) x 160(H) mm			
Weight*	Approx. 1.35Kg (without BU-25 battery).			
Monitor	2.5 inch color monitor			
Standard performance				
Splice Loss (typical)*1	SMF: 0.05dB, MMF: 0.03dB, DSF: 0.08dB, NZDSF: 0.08dB			
Splice cycle time*1	Approx. 15 sec. (for 4c ribbon fiber)	Approx. 11 sec.	Approx. 11 sec.	
Heat shrink oven cycle time*2	Approx. 40 sec. (for 40mm ribbon fiber protection sleeve)	Approx. 55 sec. (for 60mm single fiber protection sleeve)	Approx. 55 sec. (for 60mm single fiber protection sleeve)	
Splice cycles per fully charged battery*3	Approx. 60 splices			
Function				
Splice loss estimation	○			
Splice data storage	1500 splices			
Tension test *4	1.96N			
Heat shrink oven	○			
Arc test	○			
V-groove illumination	○			
Programs				
Splice programs	Max. 15			
Heating programs	Max. 15			
Power supply				
Power supply	DC operation (with battery), AC operation (with ADC-1240)			
DC operation	Lithium-Ion battery "BU-25" Nominal voltage 11.1V, Nominal capacity 2000mAh			
AC operation	Operated with AC adapter ADC-1240 Input 100 to 240V, 50/60Hz Output DC 12V (for heated jacket remover)			
Interface	USB1.1 type-B			
Environmental conditions				
Operation temperature *5	-10 to +50°C			
Storage temperature *5 *6	-40 to +70°C			
Altitude	0 to 3,660m			
Windproof	Max. 15m/s			

* Fiber holders are provided in a standard package. Use the fiber holders suitable for the application.

*1: With identical Sumitomo fibers in room temperature

- *2: AC power supply is used in room temperature (20°C). In battery operation, heat shrink oven cycle time is longer depending on the outside temperature or the battery remaining capacity.
- *3: A three-minute splice and heating cycle is repeated with a new fully charged battery in room temperature.
- *4: Performed on the stage after splicing.
- *5: Non-condensing
- *6: Battery storage temperature range is 0 to 45°C (if stored for less than 1 month). For further details, please refer to the battery specifications.

Standard Equipment

Item	Description
<BU-25 battery> Please read the Chapter 2 before use.	
Battery	Lithium-Ion battery
Nominal voltage	11.1 V
Nominal capacity	2000mAh
<ADC-1240 AC adapter>*1	
Input voltage	AC 100 to 240 V, 50/60Hz
Output voltage	DC 12V

*1: The ADC-1240 is AC adapter for AC operation of TYPE-25e.

Optional accessories

Item	Description
<BC-25A battery charger>*1 Please read the Chapter 2 before use.	
Input voltage	DC 16V
Terminals	DC input terminal (for ADC-1635)
	DC output terminal (for charging BU-25)
The number of battery cells to be charged	2
<ADC-1635 AC adapter>*2	
Input voltage	AC 100 to 240 V, 50/60Hz
Output voltage	DC 16V

*1: The BC-25A is a battery charger only for the BU-25.

*2: The ADC-1635 is AC adapter used for the BC-25A.

Notification of North American patents on the TYPE-25e series

U.S. Patents

4,812,010

5,777,867

6,437,299

6,518,551

CANADA Patent

2,183,840

Warranty and repair ser-

Before requesting a repair, try to locate the problem and identify the cause by referring to “5 Troubleshooting” at page 47. If you ensure that your machine is really in need of a repair, contact our maintenance service center.

Warranty period

1. We warrant that this brand-new product (TYPE-25e fusion splicer, installed software, and other equipment), in the course of its normal use, will be free from defect in materials and workmanship for one year (except consumables) from the date you acquire it.

Services after warranty period

After the warranty period expires, all products may be repaired for a reasonable service charge.

2. The following cases are the exception for repairing and replacing the product free of charge.
 - (1) Damage or malfunction caused by misuse, mishandling, non qualified repair, disassembly, modification, or any other irregular execution
 - (2) Damage or malfunction caused by drop, fall or any other faulty treatment such as to be explained in precautions on this manual.
 - (3) Damage or malfunction caused by actions that are beyond Sumitomo’s control including for example, fire, water flood, earthquake, lightening or similar disaster, or any other accident.
 - (4) Damage or malfunction caused by the use of Product in conjunction with accessories, products, or consumables not specified or approved by Sumitomo.
 - (5) Replacement of consumables
 - (6) Travel expense that is charged if a trip for repair is requested by the customer.
 - (7) Damage or malfunction caused by use of batteries and battery chargers not specified or approved by Sumitomo.
 - (8) Products founds corroded due to exposure to water or dew condensation, or cracked or deformed circuit board.
3. The customer shall bear the cost of returning the product to Sumitomo.

<Availability of spare parts>

The availability of spare parts for the splicer must be guaranteed for a period of 7 years from the date of the sale. However due to various reasons, spare parts for repair might be impossible to get within such period.

SERVICE INFORMATION

Tokyo (JAPAN)

Sumitomo Electric Industries, Ltd.

3-12, Moto-Akasaka 1-chome, Minato-ku, Tokyo 107-8468 Japan

Tel +81 (0)3 3423 5889

<http://www.sei.co.jp>

North Carolina (U.S.A.)

Sumitomo Electric Lightwave Corp.

78 Alexander Drive, PO Box 13445, Research Triangle Park, NC 27709 U.S.A

Tel +1 919 541 8100

<http://www.sumitomoelectric.com>

London (U.K.)

Sumitomo Electric Europe Ltd.

220 Centennial Park, Centennial Avenue, Elstree, Herts, WD6 3SL, U.K.

Tel +44 (0)20 8953 8118

<http://www.sumielectric.com>