



(PRELIMINARY)
OME1324115-2

Direct Core Monitoring Optical Fiber Fusion Splicer

TYPE-Q101-CA+

Guide to operation

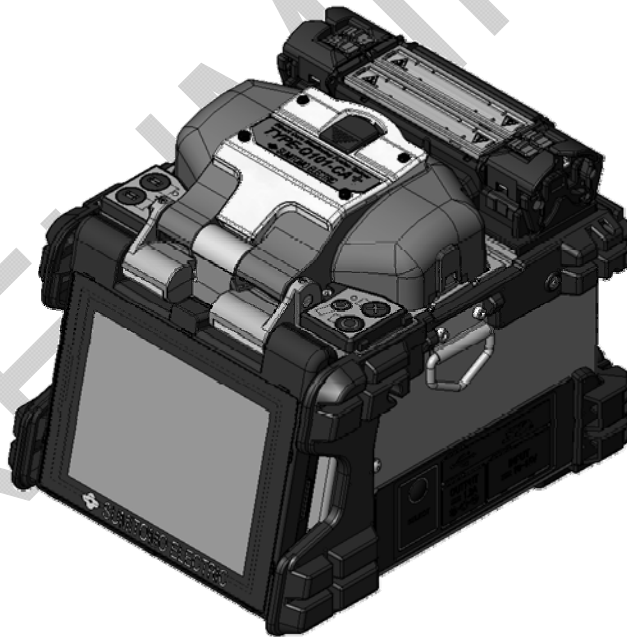

 **SUMITOMO ELECTRIC**
Ingenious Dynamics

IMPORTANT SAFETY PRECAUTIONS

This product has been designed and manufactured to assure personal safety. Improper use can result in fire, electric shock or injury to persons. Please read and observe all warnings instructions given in this operation manual.

Use your splicer only for its intended purpose.



◆ The meaning of these symbols

In the product and this operation manual, symbols are used to highlight warnings and cautions for you to read so that accidents can be prevented. The meanings of these symbols are as follows:



○Symbol used in the product

	This symbol, where it appears on the unit, indicates that hazardous voltage is present inside of the splicer.
---	---

○The meaning of these symbols

	This symbol indicates a warning, caution, or danger and alerts you important instructions have been included on the product or in the manual.
	This symbol indicates actions that are prohibited.
	This symbol indicates actions that must be taken.

○The meaning of Warning and Caution

 Warning	This symbol indicates explanations about extremely dangerous matters. If users ignore this symbol and handle the splicer the wrong way, serious injury such as fire or electric shock, or death could result.
 Caution	This symbol indicates explanations about dangerous matters. If users ignore this symbol and handle the splicer the wrong way, bodily injury and damage to the equipment could result.

Be sure to read all the following warnings and cautions before use.



<Setting up and using splicer>



	<ol style="list-style-type: none">1. This fusion splicer performs an arc discharge. Do not use the splicer in a hazardous location in which inflammable gas can generate or only electrical apparatus for explosive gas atmosphere can be used.2. Never use spray cleaners such as Freon or Flammable gas on the splicer. Decomposition of arc by heat will cause toxic gas, or abnormal arc may result in damage or fire.
---	---





3. Do not use and store the splicer out of the locations defined in a brochure and this manual. Doing so can cause splicer malfunction or deterioration, resulting in fire or electric shock.
4. To reduce the risk of fire, electric shock or malfunction, do not allow the splicer to be exposed to rain and get liquid such as water or a metallic object inside the splicer. Doing so can cause fire, electric shock or malfunction by shorting out internal components.
5. Never use the battery pack, AC adapter and battery charger, and power cables for the machines other than the specified splicer. Doing so can cause these items to damage, resulting in fire or heat generation.
6. Do not make mechanical or electrical modifications to the splicer since this may expose you to dangerous voltage or other hazards.
7. Do not touch the electrodes during and after arc discharge. Doing so can cause personal injury or electric shock.
8. The heating plate of the heat shrink oven may be hot during heating. Do not touch the protection sleeve directly after heating. Doing so can cause burn. A protection sleeve may also be hot after heating. Handle with care.
9. Do not operate the splicer in the rain. Doing so can cause AC adapter or battery pack to be short-circuited.
10. Do not expose the splicer to extremely high temperature and high humidity or to direct sunlight for prolonged periods.
11. Do not continuously use the heat shrink oven for long hours, keeping it high temperature. Doing so can cause heat shrink oven to malfunction.
The following case is the exception for repairing and replacing the product free of charge:
The Heating duration is set to a long time (e.g. 180 sec.) and the Finish temperature is set to a high temperature (e.g. 200 °C). The heat shrink oven is used for long hours by continuing to press the Heat key shortly after the heat cycle is completed.
12. Only use alcohol to clean the splicer. To prevent malfunction and damage, do not use any other kind of chemicals.
13. Never use spray cleaners such as Freon or flammable gas on the splicer. Heat by arc can cause chemical reactions to occur to gas component, which will deteriorate a microscope lens, resulting in a loss of splicing capability.
14. Parts that compose the heat shrink ovens might become high temperatures. When those parts are damaged, do not use it and contact our service center.
15. Because it is likely to injure by shards of glass when the monitor is damaged, do not use it and contact our service center.
16. When parts that compose this product and the accessory (battery pack, AC adapter, and power cord, etc.) are damaged, do not use it and contact our service center.
17. If this product gets wet with dew or the like, do not turn it on.
18. Do not use this product near the electronic equipment that handles a highly accurate control and the faint signal such as the heart pacer. The influence of the miss-operation of electronic equipment might be given.

	<p>19. Avoid places with too much dust or dirt. Dirt or dust that can accumulate in the fusion splicer causes short circuit and insufficient cooling, which may lead to splicer malfunction or deterioration, resulting in fire or electric shock.</p> <p>20. Only use the battery pack, AC adapter, battery charger and power supply cord for the splicer as defined in this manual. Failure to do so can cause these items or the fusion splicer to damage, resulting in fire or electric shock.</p> <p>21. Only use a voltage within the indicated power voltage. Failure to do so can cause fire or electric shock.</p> <p>22. Check for condensation before operation. If this product gets wet with dew or the like, leave it in a room temperature for about one day before turning it on. If water or other liquid, a metallic object or other foreign substance gets inside the splicer, immediately turn off the power and disconnect the power plug. Contact our qualified service personnel.</p> <p>23. In a high location, take safety measures to prevent fall of operators. Dropping the splicer could result in personal injury. Fix the splicer to a worktable or a tripod with the screw on the bottom of the splicer.</p> <p>24. If an abnormal condition such as unusual noise, smoke or unusual odor occurs, immediately turn off the power and disconnect the power plug. Next, contact our qualified service personnel.</p> <p>25. Be sure to turn off the splicer and unplug the power cord or remove the battery pack before replacing the electrodes.</p> <p>26. Only use Sumitomo genuine electrodes (ER-10). And use the splicer with electrodes installed in it. Failure to do so can cause the splicer to damage, resulting in fire, electric shock or malfunction.</p>
---	---

<Handling of power cord and plug >

	<p>1. To reduce the risk of electric shock, do not plug/unplug the power cord or remove the battery pack with wet hands.</p>
	<p>2. Disconnect the power cord by grasping the plug, not the cord. Failure to do so can cause damage to the power cord, resulting in fire, electric shock or malfunction.</p> <p>3. Before charging the battery pack, make sure that the pins of the battery charge cord are not bent or broken. Using the battery charge cord with a bent or broken pin can cause internal short circuit, resulting in fire or electric shock.</p>

<Handling of battery pack>



	<ol style="list-style-type: none">1. Do not burn the battery pack or throw it into a fire. Doing so can cause heat generation, bursting and fire.2. Do not place the battery pack in microwave ovens and high-pressure containers.3. Do not let water or sea water wet or soak the battery pack. Safety and protective devices to prevent danger are built in the battery pack. If these devices are damaged, excessive current flow can cause abnormal chemical reaction in battery fluid, heat generation, bursting and fire.4. Do not throw or impact the battery pack. Safety and protective devices to prevent danger are built in the battery pack. If these devices are damaged, excessive current flow can cause abnormal chemical reaction in battery fluid, heat generation, bursting and fire.5. Do not pierce the battery pack with nails, strike the battery pack with a hammer, or step on the battery pack. Doing so can cause internal short circuit, heat generation, bursting and fire.6. Do not disassemble or modify the battery pack. Safety and protective devices to prevent danger are built in the battery pack. If these devices are damaged, excessive current flow can cause loss of control during charging or discharging of the battery pack, heat generation, bursting and fire.7. Make sure the polarities are correctly connected. Do not attempt to connect the battery pack or other equipment when you cannot do. Reversed connections can cause abnormal chemical reaction in battery fluid, heat generation, bursting and fire.8. Do not solder any lead wires directly to the battery pack. Do not directly connect the positive and negative terminals with a conductive material such as a wire. Do not carry or store the battery pack together with any personal jewelry, hairpins or other Metallic objects. Doing so can cause an electrical short circuit. Also excessive current flow can cause abnormal chemical reaction in battery, heat generation, bursting and fire.
	<ol style="list-style-type: none">9. Only use a specified battery charger. Failure to do so can cause the battery to be overcharged or excessive current flow can cause abnormal chemical reaction in battery fluid, heat generation, bursting and fire.10. Use the battery pack only for the application for which it was designed. Failure to do so will result in a loss of performance and a shortened life expectancy. Also excessive current flow can cause loss of control during charging or discharging of the battery pack heat generation, bursting and fire.





<Transportation and storage>

	<ol style="list-style-type: none">1. This product is a precision instrument. When transporting the splicer, use its specified carrying case to protect the splicer from excessive shock or impact.2. Do not use and store the splicer out of the locations defined in a brochure and this manual. Failure to do so can cause splicer malfunction or deterioration, resulting in fire or electric shock.3. Do not store any items other than the product, package contents and optional accessories in the carrying case. Overloading the case can cause damage to the body of the carrying case, case handle, strap and latch.4. Do not throw or fall the carrying case. Doing so can cause damage to the body of the carrying case, case handle, strap and latch.5. Do not use a carrying case where there is a visible sign of damage and screw looseness.6. Do not store the hand strap in the windshield. It causes damage to the machine.7. Do not carry the machine grabbing the hood or the monitor.8. Do not brandish the machine with the hand strap, and brandish neither AC adapter nor the power cord. There are fear of machine damage and the injury.9. Do not use the machine with the lid of the battery Pack slot opened.
	<ol style="list-style-type: none">10. When shipping this product, inform the transport company that this product contains the lithium-Ion battery. Follow the direction of the transport company.11. Before carrying the case, make sure that there is no visible sign of damage and screw looseness on the handle and latch. If the case with damage and screw looseness is carried, it could drop down, causing personal injury or splicer malfunction.12. Before picking up the case, ensure that the latch is completely locked. Carrying the case with the latch unlocked can cause the case to fall open and result in personal injury or splicer malfunction due to heavy impact.13. Be careful that your fingers not to be caught in the hinge part and the lid when you open and shut the case.14. Confirm the work table of the carrying case is surely fixed to the case when you carry it.15. Do not modify the handle, strap or strap attachment points. Only use the carrying strap supplied by us.16. Avoid places with too much dust or dirt. Dirt or dust that can accumulate in the fusion splicer causes short circuit and insufficient cooling, which may lead to splicer malfunction or deterioration, resulting in fire or electric shock.17. If you are not going to use the splicer, remove the battery pack from the splicer. Failure to do so will shorten a battery life.18. Unplug the fusion splicer or remove the battery pack before attempting any maintenance or if not using the splicer for a prolonged period. Failure to do so can cause fire.19. The monitor, the hood, and the heater clamping, etc. do the opening and shutting operation. Be careful of your fingers not to be caught.

<Battery handling and charging>

	<ol style="list-style-type: none">1. Make sure the polarities are correctly connected. Do not attempt to connect the battery pack or other equipment when you cannot do. Reversed connections can cause abnormal chemical reaction in battery fluid, heat generation, bursting and fire.2. Do not carry or store the battery pack together with any personal jewelry, hairpins or other Metallic objects. Doing so can cause an electrical short circuit. Also excessive current flow can cause abnormal chemical reaction in battery fluid, heat generation, bursting and fire.3. Do not use a dry cell battery and the batteries differing in capacity, type, and manufacturer. Doing so can cause heat generation, bursting and fire.
	<ol style="list-style-type: none">4. The battery's optimum charging temperature range is 0 to 40°C. Under high temperature conditions such as in direct sunlight or near a fire, safety and protective devices to prevent danger which are built in the battery pack will be activated, resulting in failure of charging. Or if these devices are damaged, excessive current flow can cause loss of control during charging or discharging of the battery pack, heat generation, bursting and fire. Avoid charging the battery pack at extremely low temperature (below 0°C). Failure to do so may lead to deterioration in performance and battery leakage.5. Always turn off the power to the splicer after use. Failure to do so can cause the battery to be over discharged and deteriorated in performance.6. In the event the fluid inside the battery leaks, take extremely care not to expose it to your eyes and skin. If it does, immediately wash them thoroughly with clean water enough from the tap and consult a doctor urgently.7. Unplug the fusion splicer or remove the battery pack before attempting any maintenance or if not using the splicer for a prolonged period. Failure to do so can cause fire.8. Pay attention not to drop the battery pack when installing and removing it. Dropping the battery pack can cause personal injury.

<Handling of optical fiber >

	<ol style="list-style-type: none">1. Never look into optical fibers or the end of an optical cable attached to the optical output when the device is active. The laser radiation can seriously damage your eyesight.
	<ol style="list-style-type: none">2. Wear safety glasses at all times for protection from glass fibers.

< Others >

	<ol style="list-style-type: none">1. Do not press the keys on the keypad with a sharp object (e.g. a ballpoint pen, screwdriver, or nail) Doing so will damage the keypad.2. Do not press strongly the touch screen with a sharp object.3. Do not use or store the battery pack at high temperature, such as in strong direct sunlight, and in cars during hot weather. This can cause deterioration of the battery.4. Even if you are not going to use the battery pack for a prolonged period, charge it once a year.5. Do not press the liquid crystal display with force or the display may fail.6. Take care to keep spliced fiber straight. Do not flex it back and forth. Doing so can cause the spliced fiber to be broken, resulting in loss of the long term reliability of the fiber.7. Do not use a canned air for cleaning. Chemical reaction may deteriorate the lens, resulting in a loss of splicing capability.
---	--



8. Check the voltage of AC power before use. The AC adapter should be grounded to earth. If voltage or frequency beyond the range stated flows in the AC adapter, a safety and protective device to prevent danger is activated and the AC adapter will stop. In that case, a new AC adapter should be purchased. Please contact our qualified service personnel.
9. Charge the battery pack within the following temperature range. Failure to do so may lead to deterioration in performance.
*Battery pack's required temperature range: 0°C ~ +40°C
10. Before using the battery pack for the first time, charge it.
11. The battery pack is consumables. Repeated charging and discharging decreases battery life.
12. Store the battery pack within the following temperature range. Failure to do so may lead to deterioration in performance.
*Battery pack storage temperature range: -20°C ~ +50°C (if stored for less than 1 months) -20°C ~ +40°C (if stored for less than 3 months) -20°C ~ +20°C (if stored for less than 1 year)
13. Charge the battery pack fully before storing it for a prolonged period.
14. Even if you are not going to use the battery pack for a prolonged period, charge it once a year.
15. If you are getting fewer than splice cycles per fully charged battery, consider replacing the battery pack by a new one.
16. When disposing of the battery pack, contact our qualified service personnel or follow the local regulations.
17. Although bright spots or dark spots may appear on the screen, this is a unique characteristic of liquid crystal displays, and such do not constitute or imply a machine defect.
18. We recommend your splicer to be annually over-hauled to keep it in good condition.
19. Glass fiber fragments are extremely sharp. Handle with care.
20. Turn off the splicer before maintenance work. Failure to do so can cause electric shock.
21. Be sure to remove moisture, alcohol or dust on the heater element with a dry cotton swab.
22. Only use Sumitomo genuine electrodes (ER-10). Failure to do so can cause the splicer to malfunction.
23. Do not clean the electrode. Doing so can cause unstable arcing performance.
24. Storing and transporting the splicer with the battery pack installed can cause the battery pack to be damaged or deteriorated, resulting in fire. Remove the battery pack from the splicer before storage.
25. Transporting the splicer with fiber holders loaded can cause the V-grooves or clamps to be damaged, resulting in the failure of splice. Remove the fiber holders from the splicer before storage.
26. Ensure that the strap should be completely secured.
27. Whenever you use the strap rings, be sure to hold the splicer with your hand. Failure to do so can cause the splicer to turn over and accessories such as fiber holder will drop.

RoHS Directive (2011/65/EU)

The TYPE-Q101-CA+ optical fusion splicer is RoHS-compliant.

WEEE Directive (Waste Electrical and Electronic Equipment; 2002/96/EC)

The European Union has enacted a Directive 2002/96/EC on Waste Electrical and Electronic Equipment (WEEE Directive). This directive is applicable in the European Union member states. The crossed out wheelie bin symbol found on our products indicates that it should not be disposed of together with household waste.

To prevent possible harm to human health and the environment, waste electrical equipment must be disposed of in an approved and environmentally safe recycling process.

For further information on how to dispose of the product correctly, please contact the product supplier, or the local authority responsible for waste disposal in your area.



IMPORTANT: REGION LIMITATION

WARNING:

This product is sold for the use in a limited sales area and the sale, resale, transfer, lease or otherwise of this product to the other regions is prohibited, except written consent of Sumitomo Electric Industries, LTD.

YOU NEED TO AGREE ABOUT A SOFTWARE LICENCE AND REGION LIMITATION BEFORE USE.

Reference of Sales Area and Sumitomo Sales & Service Representatives:

Sales Area	Sumitomo Sales and Service Representatives	
North & South America	SEL	Sumitomo Electric Lightwave Corp.
Europe, Middle east, Africa (EMEA) UK	SEEL	SEEL : Sumitomo Electric Europe Ltd.
China	SEA	Sumitomo Electric Asia, Ltd.
	SEAC	Sumiden Asia(Shenzhen) Co., Ltd.
Thai, Vietnam	SET	Sumitomo Electric(Thailand) Limited
Indonesia, Singapore	SEPS	Sumitomo Electric Interconnect Products (Singapore) Pte Ltd.
India, South Asia	SETI	SEI Trading India Pvt. Ltd.
Philippines	SEPI	SEI (philippines) Incorporated
Japan	SEI	Sumitomo Electric Industries, Ltd.

Other sales area and authorized sales and service agencies may be provided according to the country, area and trading conditions. Refer to the information which appears on the splicer screen.

IMPORTANT: PATENT NOTICE

This product and/or the use of this product are/is covered by one or more of the following Patents of Sumitomo Electric Industries, LTD.:

Australia	Patent No(s): 2002222577; 2006235914 Design No(s): 314929; 329420
Canada	Patent No(s): 2183840; 2431138 Design No(s): 120205; 133128
China P. Rep.	Patent No(s): 1820115.6; 98109577.1; 200780001246.9 Design No(s): 200730144402.X; 200930286514.8
Europe	Design No(s): 000712583-0001; 001183206-0001
France	Patent No(s): 1355177; 1892547
Germany	Patent No(s): 0880039; 1355177; 1892547
Italy	Patent No(s): 1355177; 1892547
Sweden	Patent No(s): 0880039; 1355177; 1892547
United Kingdom	Patent No(s): 0880039; 1355177; 1892547; 2420633
Hong Kong S.A.R.	Patent No(s): 1106961
India	Patent No(s): 232249 Design No(s): 209372; 225957
Japan	Patent No(s): 3065271; 3111649; 3119822; 3952822; 4032960; 4161984; 4196972; 4305468; 4367597; 4457873; 4613796 Design No(s): 1311936; 1382022
Malaysia	Design No(s): MY07-00454-0101; MY09-01316-0101
Singapore	Design No(s): D2007/402/A; D2009/1085/Z
South Korea	Patent No(s): 646124; 859070; 878095 Design No(s): 30-0472617; 30-0594853
Taiwan	Patent No(s): 1233507 Design No(s): D122221; D140150
United States	Patent No(s): 5,777,867; 6,206,583; 6,966,708; 7,140,786; 7,412,146; 7,546,020 Design No(s): D578,072; D628,462S

IMPORTANT : TYPE-Q101-CA+ SOFTWARE USER LICENSE

Copyright © 2014 SUMITOMO ELECTRIC INDUSTRIES, LTD. All rights reserved.

ATTENTION : The software installed in the TYPE-Q101-CA+ SPLICER ("this software") is the property of SUMITOMO ELECTRIC INDUSTRIES, LTD. The usage of this software is granted by a license. CAREFULLY READ AND THIS LICENSE BEFORE USING THIS PRODUCT.

The copyright and all other rights to this software, its documentation and the writings concerning this software ("the writings"), which contain CD-ROM, operation manual, guiding document, data tables, command lists, writing information (photos, images, drawing, text) on appended other printed materials, shall remain with SUMITOMO ELECTRIC INDUSTRIES, LTD. By commencing the use of this software, you acknowledge that you have read the following license and indicate that you agree to its terms. In case of disagreement, contact SUMITOMO ELECTRIC INDUSTRIES, LTD. or our product supplier.

LICENSE AGREEMENT

This license is the entire agreement between SUMITOMO ELECTRIC INDUSTRIES, LTD. and you.

1. LICENSE

The following restricted rights are granted. YOU MAY :

- a) use on a splicer in which this software is installed.
- b) create or distribute a construction manual based on the writings on condition that you clarify their source.
- c) create an execution report of construction based on displayed information, and the writings.
- d) create a document (manual or execution report) concerning the maintenance of the splicer in which this software is installed or control its splice-quality upon displayed information and the writings.
- e) make one copy of the writings for archival or backup purpose.

2. RESTRICTIONS

The following act is forbidden on this license, except our prior written consent. YOU MAY NOT :

- 1) sell, distribute, rent, lease, transfer, or disclose the whole or part of the writings to the public or unidentified parties and transfer, disclose or display the electrical format of the writings through online media.
- 2) make copy of the writings except as permitted in this license.
- 3) reverse engineer, decompile, disassemble this software and analyze, modify or merge the program.

3. CONTRACTING PARTIES

If you rent, lease, transfer, or resell the splicer, in which this software is installed, to a corporation or other entity, then this agreement is formed by and between SUMITOMO ELECTRIC INDUSTRIES, LTD. and such entity. You shall be liable for such entity to agree to the same all conditions of this license.

4. TERM AND TERMINATION

This agreement shall continue in effect until terminated. You may terminate the agreement at anytime by stopping the use of the splicer in which this software is installed. If you fail to comply with any of the provision of this license, your license will be automatically terminated. Upon termination, you shall transfer the writings to the owner of splicer (In the case that you transfer the splicer to other corporation or entity) or return them to us, otherwise erase or destroy them by appropriate means. You shall forever hold in confidence all trade secrets brought by this license. Further you agree not to disclose to any third party.

5. LIMITATION OF LIABILITY

SUMITOMO ELECTRIC INDUSTRIES, LTD. and our supplier shall not be liable for consequential, incidental or accidental damages in connection with this software or this agreement and whether this software shall meet your special requirements, special efforts or special method beyond the range described in the operation manual concerning this software.

6. GENERAL

If any provision of this agreement is declared by the court of competent jurisdiction to be invalid, illegal, or unenforceable, such provision shall be severed from the agreement and the other provisions shall remain in full force and effect.

The followings are a registered trademark or trademark of Corning Incorporated.
Corning®, LEAF®, MetroCor®, ClearCurve™

TrueWave® is a registered trademark of Furukawa Electric North America, Inc.

BendBright® and TeraLight™ are a registered trademark or trademark of Draka holding.

CasaLight™ is a trademark of Prysmian Cables and Systems.

The followings are a registered trademark or trademark of Sumitomo Electric Industries, Ltd.
MicroCore™, Sumitomo Z™, PureGuide®, PureMetor®, PureAccess®, UltraAccess®, SumiFi®

SD and SDHC logos are trademarks of the SD-3C LLC.



FlashFX® Pro™ is a trademark of Datalight, Inc.

Android is a trademark or registered trademark of Google Inc.

Google Play is a trademark or registered trademark of Google Inc.

Wi-Fi® is a registered trademark of the Wi-Fi Alliance.

PRELIMINARY

Table of contents

IMPORTANT SAFETY PRECAUTIONS
IMPORTANT: REGION LIMITATION
IMPORTANT: PATENT NOTICE
IMPORTANT: TYPE-Q101-CA+ SOFTWARE USER LICENSE

1. General	1-1
Product overview	1-1
Optical fiber requirement	1-1
Features overview	1-1
Standard package	1-2
Optional accessories	1-3
Consumables	1-4
Structure	1-5
Fusion splicer	1-5
Keypad	1-6
V-grooves, electrodes, other components	1-7
Heat shrink oven	1-8
Input/output panel	1-8
Caution label	1-9
2. Splice / Protection	2-1
Preparing power supply	2-2
AC operation	2-2
Battery operation	2-3
Battery level check	2-4
Battery charging	2-5
DC operation (car battery)	2-6
Precautions for battery pack	2-6
Operating procedures	2-7
Turning on the TYPE-Q101-CA+	2-7
Initial screen	2-8
Stripping the fiber coating / Cleaning the bare fiber	2-9
Cleaving the fiber	2-10
Inserting fibers into the splicer	2-12
Arc test	2-13
Arc test procedure	2-13
Fiber preparation	2-15
Starting the automatic splice	2-16
Splice protection	2-20
Drop cable splicing	2-22
Applicable cable	2-22
Required items	2-22
Preparation	2-22
Removing cable sheath	2-23
Fiber preparation procedures 1 (AP-FC6SA is available)	2-24
Fiber preparation procedures 2 (AP-FC6SA is not available)	2-26
Inserting the fiber into the splicer	2-27
Splice protection	2-28

3. Daily cleaning and checking up	3-1
Cleaning	3-1
Names of components	3-1
Cleaning V-grooves	3-2
Cleaning LEDs	3-2
Cleaning bare fiber pads	3-3
Cleaning lens protection glass	3-3
Cleaning heat shrink oven	3-4
Replacing electrodes	3-5
Electrode replacement procedures	3-6
Packing and storage instructions	3-8
4. Functions	4-1
Splice and heater program settings	4-1
Function settings	4-11
Maintenance settings	4-14
Splice data storage function	4-15
USB connection function	4-16
Software download via internet	4-16
Login function	4-16
Help function	4-17
Wireless LAN feature	4-18
SumiFi smartphone application features	4-18
5. Other convenient functions	5-1
Back monitor type	5-1
Universal clamp	5-2
Dual heat shrink oven	5-2
Fiber holder operation	5-3
Detachable/attachable bare fiber pads	5-4
Heater clamp operation	5-5
Auto start	5-6
Tripod fixing screws	5-6
Hand strap	5-7
6. Troubleshooting	6-1
Arc problems	6-1
Fiber breaking	6-1
Splicer does not power up	6-1
Warranty and repair service	6-2
Error message list	6-3
TYPE-Q101-CA+ Specifications	6-4

PRELIMINARY

1. General

Thank you very much for purchasing the TYPE-Q101-CA+ Fusion Splicer (hereinafter called “the TYPE-Q101-CA+”).

The TYPE-Q101-CA+ automatically pre-inspects and aligns a pair of optical single fibers with equipped microscopes, and then fuses them together with heat from an electric arc to form a low-loss splice. A protection sleeve is applied over the bare glass and cured in the built-in heat shrink oven.

Before using the TYPE-Q101-CA+, read all instructions completely.



Caution

Read this manual carefully in its entirety to fully understand machine capabilities. Save this manual in a location in which you can easily get to see.

Product overview

Optical fiber requirement

The TYPE-Q101-CA+ can splice the following optical fiber types.

Material	Silica glass
Profile type	SMF (ITU-T G.652), MMF (ITU-T G.651), DSF (ITU-T G.653), CSF (ITU-T G.654), NZDSF (ITU-T G.655, G.656), BIF (ITU-T G.657), EDF
Fiber diameter	80 - 150 μ m *1
Fiber coating diameter	100 - 1,000 μ m
Fiber count	Single fiber
Cleave length *2	5 - 16mm *3

*1 Fiber diameter except 125 μ m are only applied in room temperature and 0m altitude.

*2 The applicable fiber protection sleeves vary depending on the cleave length.

*3 Over 250 μ m coating diameter with the length less than 8mm requires fiber holder operation.

Features overview

The TYPE-Q101-CA+ key features are:

- **Wireless LAN (Wi-fi) & Smartphone linkage** (For more information, refer to page 4-18.)

Using the dedicated wireless LAN SD card, you can connect the splicer to a smartphone, add GPS information to saved splice data and send the data by email. Splice settings can also be edited via the smartphone.

- **Touch screen monitor** (For more information, refer to page 2-8.)

4.1 inch LCD monitor with touch screen operation enables to confirm fiber images easily. The splicer can be operated by touching the icons on the screen. The working efficiency has improved dramatically.

- **Dual heat shrink oven** (For more information, refer to page 2-20, 5-2.)
2 heat shrink ovens are equipped with the fusion splicer. The ovens run individually and splicing operation can be improved more effectively.
- **Auto start** (For more information, refer to page 5-6.)
In addition to the function that automatically starts the splicing process when the hood is closed, the function that automatically starts the heating cycle when fiber is placed into the heat shrink oven is provided.
- **Fully automatic splice mode (Auto mode)**
 - (1) Auto fiber profiling check and Detection System (For more information, refer to page 4-3.)
Using Auto fiber Profiling check and Detection System (APDS), the TYPE-Q101-CA+ recognizes fiber core profile and automatically chooses a correct splice program, and proceeds to splicing.
 - (2) Automatic arc calibration (For more information, refer to page 2-13.)
TYPE-Q101-CA+ analyzes the arc and has the function to calibrate the arc condition automatically at each splice. Therefore, arc test is not needed usually in the Auto mode.

Standard package

Here is an example of TYPE-Q101-CA+ standard package.

Package contents (example)

No.	Description	Part number	Quantity
1	Fusion splicer TYPE-Q101-CA+	TYPE-Q101-CA+	1 pc
2	AC adapter	ADC-1430S	1 pc
3	Power cord	PC-AC<X>	1 pc
4	Battery pack	BU-11/BU-11S	1 pc
5	Cooling tray	-	1 pc
6	Spare electrodes	ER-10	1 pair (2 pcs)
7	Operation manual (CD-ROM)	OME1324115*	1 pc
8	Quick reference guide	OME1324121*	1 pc
9	Carrying case (with strap)	CC-71+	1 pc

*The latest version is provided.

The above package is an example. The package contents vary depending on the customers' requests.

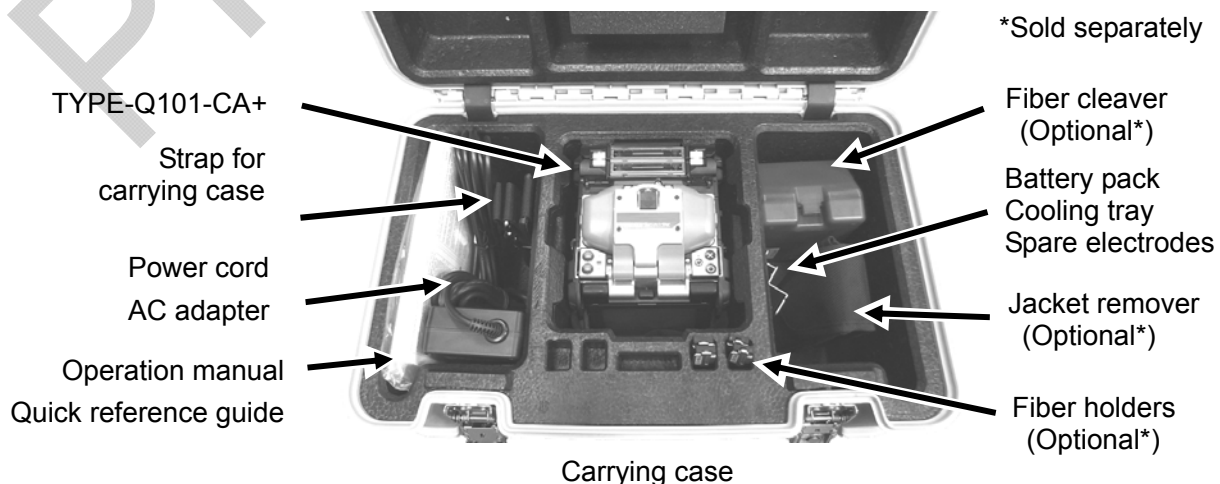

Optional accessories

The following optional accessories are provided for the TYPE-Q101-CA+. For further details, please contact our sales personnel.

Part name	Part No.	Description	Quantity
<Optional accessories for main unit>			
Battery pack	BU-11/11S	Li-ion battery for TYPE-Q101-CA+	1 pc
Car battery cable	PCV-11	Plugged into a car's cigarette light jack to supply power to splicer	1 pc
AC adapter	ADC-1430S	AC adapter for TYPE-Q101-CA+	1 pc
Battery charger	BC-11	Use only for the battery pack BU-11/11S	1 pc
Wireless LAN SD card	WLSD-0208	Dedicated Wireless LAN SD card for the TYPE-Q101-CA+	1 pc
Fiber holders	FHS-025	For 0.25mm coated fiber	1 pair
	FHS-09	For 0.9mm coated fiber	1 pair
	FHS-05	For 0.5mm coated fiber	1 pair
	FHD-1	For drop and indoor cable	1 pair
Dispenser	HR-3	Dispenser for alcohol	1 pc
<Tools>			
Fiber cleaver	FC-7R-S	Applicable coating diameter: 250 - 900 μ m	1 pc
	FC-6S(-C)	Applicable fiber diameter: 125 μ m	1 pc
	FC-6RS(-C)	Replacement blade for FC-7R: FCP-20BL(7R)	1 pc
	FC-6S-5C	Replacement blade for FC-7 and FC-6: FCP-20BL	1 pc
Jacket remover	JR-M03	Applicable coating diameter: 250 μ m, 900 μ m Applicable fiber diameter: 125 μ m	1 pc

Consumables

Fiber protection sleeves, electrodes and battery pack are consumables. Please place an order if you need any.

Part name	Part No.	Description	Quantity
Fiber protection sleeves	FPS-1	For single fiber ϕ 0.25mm~0.9mm Length 60mm, Cleave length \leq 16mm	50 pcs/pack
	FPS-40	For single fiber ϕ 0.25mm~0.9mm Length 40mm, Cleave length \leq 10mm	50 pcs/pack
Fiber protection sleeve for cable sheath	FPS-D60	For drop cable, small-sized indoor cable Length 60mm, Cleave length \leq 10mm	25 pcs/pack
Electrodes	ER-10	These parts degrade with time and usage and cannot be recycled. New parts as a replacement should be purchased.	1 pair
Battery pack	BU-11/11S		1 pc

- Regarding standard equipment, consumables, or optional accessories, please order the new item you need with the item description and part number to our sales personnel.
- For repair, please read “Warranty and repair service” at page 6-2 and contact our maintenance service center.

Structure

Fusion splicer

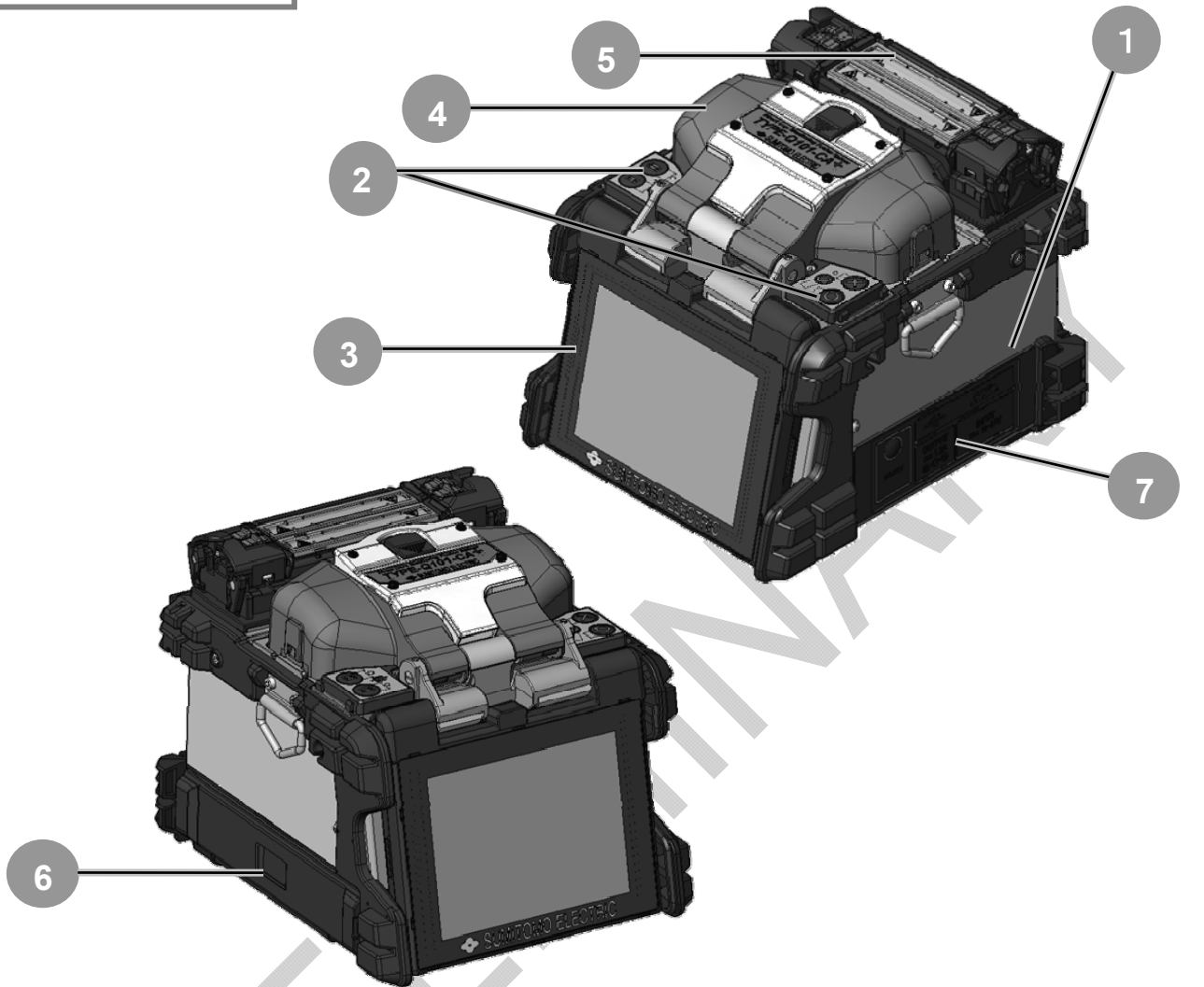

1 Main body
TYPE-Q101-CA+ fusion splicer

2 Keypad
Keys are used to turn on/off the power, perform a splice and heat shrink protection, and setup functions.

3 Touch screen monitor
Displays fiber image, splice data and menu. Touch screen operation enables to start splicing, heating and feature setting.

4 Hood
Provides protection from the environment.

5 Heat shrink oven
Used to heat and shrink fiber protection sleeves. 2 heat shrink ovens (front and rear) are equipped.

6 Battery pack slot
Battery is installed in this slot with protection lid.

7 Input/output panel
DC output terminal for hot jacket remover and USB port

Keypad

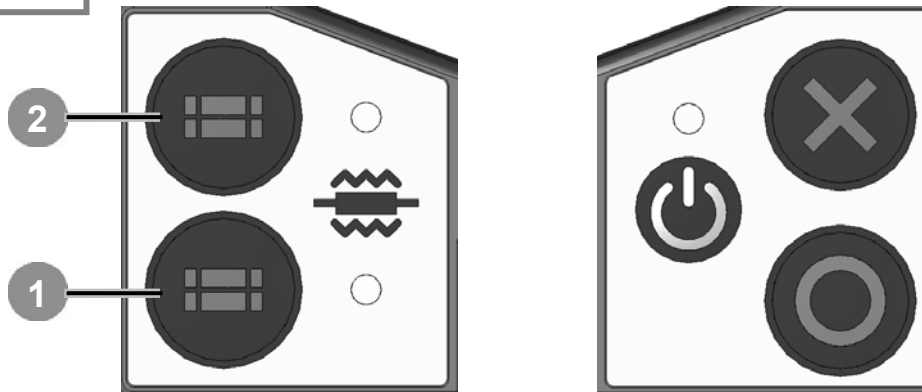

HEAT key 1 / LED

Starts/cancels the heating cycle of the front heat shrink oven.



HEAT key 2 / LED

Starts/cancels the heating cycle of the rear heat shrink oven.

The LED illuminates during the heat cycle.

It blinks during the cooling and pre-heating processes.



Power key / LED

Used to turn on and off the splicer. LED illuminates while the splicer is on.



RESET key

Used to cancel a splicing operation. Initialization



SET key

Starts a splicing operation.

The keys above are mounted on the upper surface of the splicer. The features of SET, RESET and HEAT keys are also operated by the touch screen on the monitor.

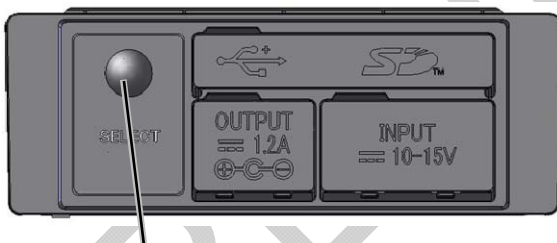

Select switch (on the Input/output panel)

Use this switch when the touch screen on the monitor breaks down.

*** Once select switch is used as the following, splice program is fixed to "auto mode" as long as the touch screen is out of order. We recommend contacting our service center soon when the touch screen function does not work.**

[Procedure]

- 1) If you found the touch screen function does not work, please turn the power OFF once.
- 2) Turn the power ON with "select switch" being pushed.
- 3) "Heater program setting" screen will be indicated (refer to page 4-2). You can select heater program with HEAT keys (up/down), and determine with SET key. Splice program is set as "auto mode" automatically.



Do not press the keys on the keypad with a sharp object (e.g. a ballpoint pen, screwdriver, or nail) Doing so will damage the keypad.

V-grooves, electrodes, other components

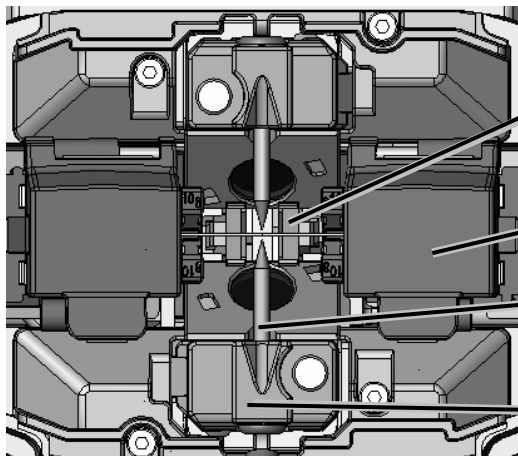

- 1 V-grooves**
Keep bare fibers aligned.
- 2 Fiber coating clamp**
Holds fiber coating.
- 3 Electrodes**
Arc is generated between the electrodes.
- 4 Electrode cover plate**
Holds the electrode seated into the retaining groove.

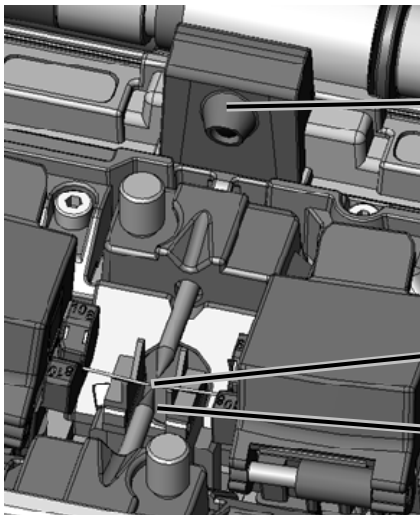

- 5 V-groove illumination**
Illuminates the V-groove. Lit when the hood is opened.
- 6 Lens protection glass**
Protects the lens surface.
- 7 Microscope objective lens**
Fiber is observed with the lens.

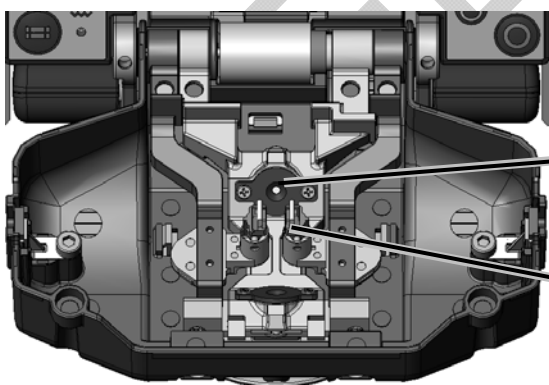

- 8 LED for fiber observation**
Illuminates the fiber and make an image on the microscope.
- 9 Bare fiber pads**
Hold fibers seated into the V-grooves. Normally they are attached to the hood.

Heat shrink oven

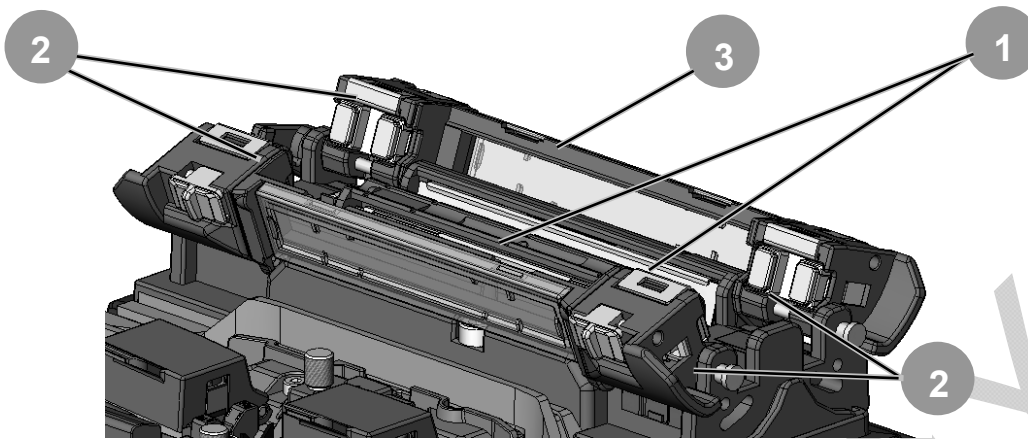

1 Heating plate
Heats fiber protection sleeve.

2 Heat shrink oven clamps
Hold fibers straight.

3 Heat shrink oven lid

Input/output panel

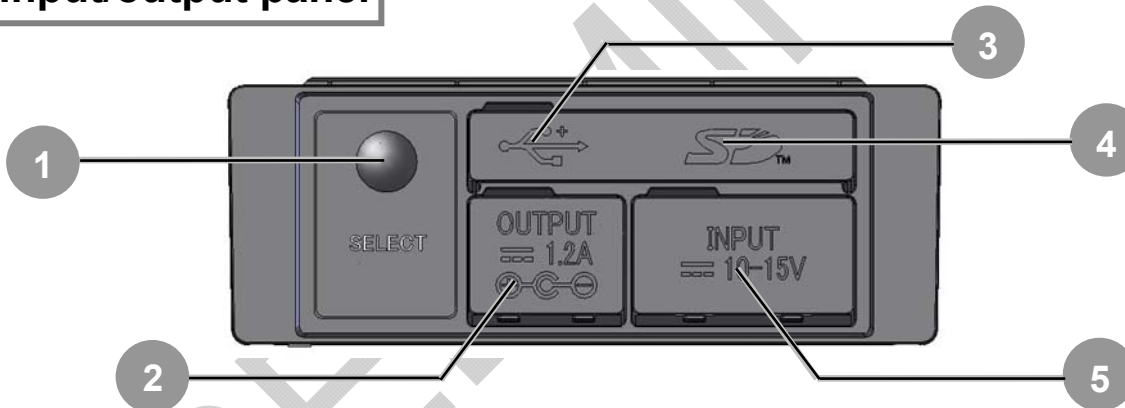

1 Select switch
Refer to page 1-6.

2 DC output terminal
Used to supply DC power to a hot jacket remover.

3 USB port
Used to download stored splice loss data when connected to a PC.

4 SD card slot
for splice data output.

5 DC input terminal
input power via AC adapter.

Caution label

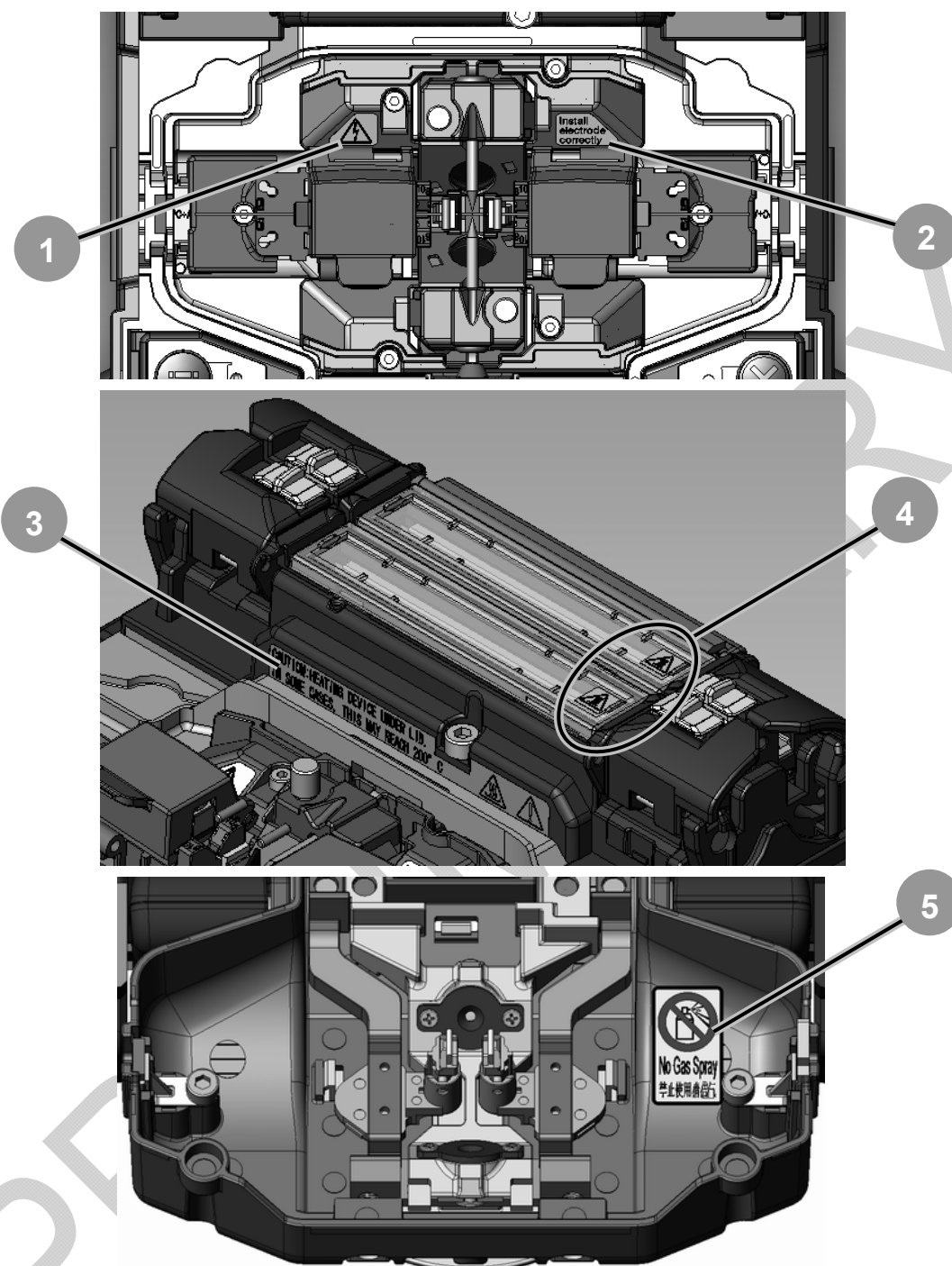

1

High voltage

When the arc is discharged, a high voltage is generated in the electrode. Please pull out the power cord, and detach the battery pack when you touch the electrode.

2

Installing electrode

Please confirm whether the electrode is installed without fail before splicing.

3

High temperature heater

Heaters may reach 200°C. Please take care when you use heaters.

4

5

Prohibition of using spray

Do not use any gas spray such as gas duster or canned air.

PRELIMINARY

2. Splice / Protection

[Preparation for splicing]

Before splicing, collect all of the necessary equipment.

- TYPE-Q101-CA+
- Optical fiber being spliced
- Jacket remover
- Fiber cleaver

- Pure (more than 99%) alcohol
- Lint-free gauze wipes
- Fiber protection sleeves*

*Note that the applicable fiber protection sleeves vary depending on the cleave length.

[Operating procedures]

The following is a summary of the steps required to make a splice with the fusion splicer. For further information on each step, please see the page described below.

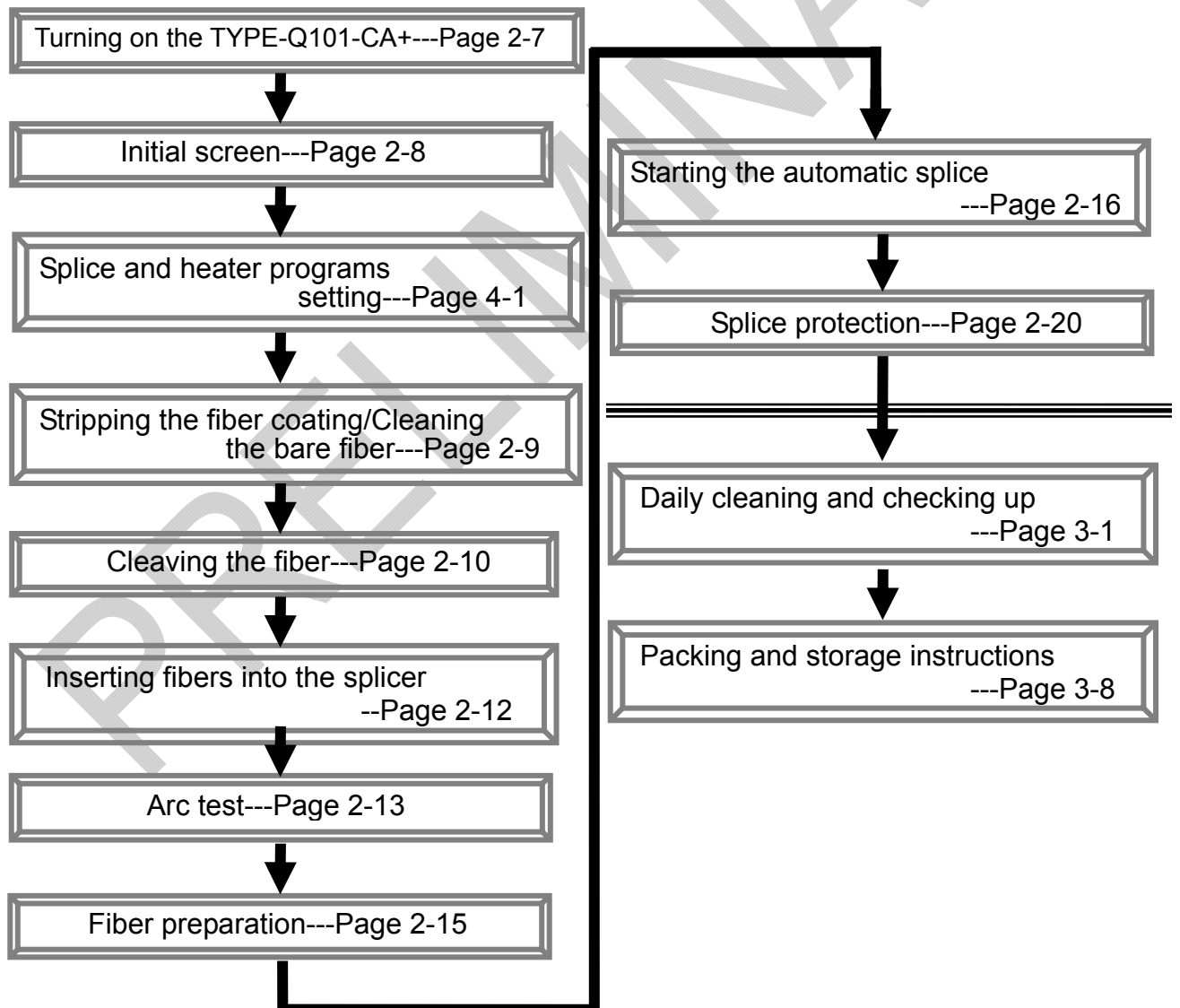

Preparing power supply

The power for TYPE-Q101-CA+ is supplied by AC adapter or battery.

AC operation

Please connect AC adapter (ADC-1430S) with TYPE-Q101-CA+ when you operate with the AC adapter.

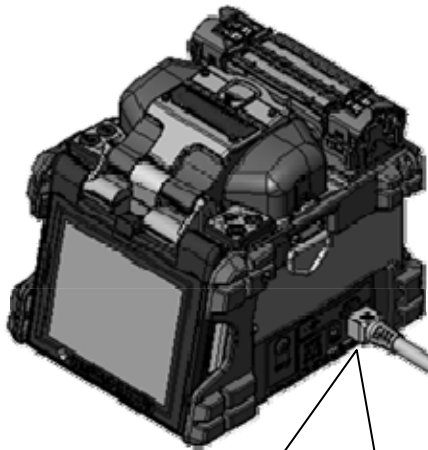

Connect the output cord of AC adapter with DC input terminal of TYPE-Q101-CA+.

Plugging

Insert the power cord into the AC adapter completely. POWER LED lights up green when the power is supplied.

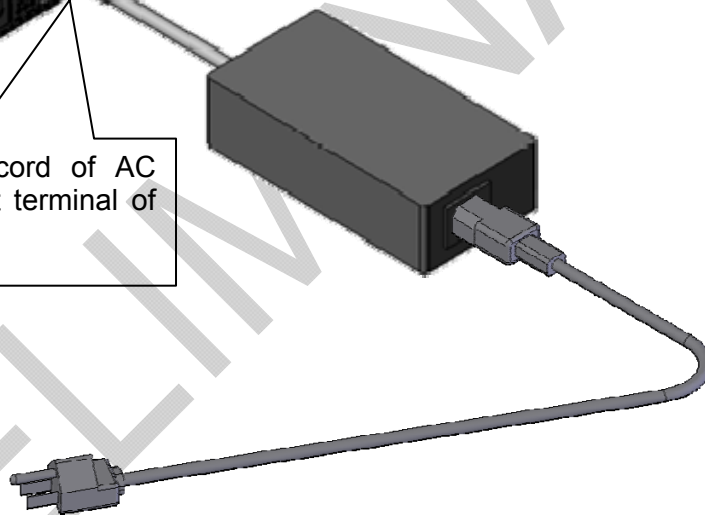

1. Please confirm the voltage of the AC power supply before using. Moreover, please earth the AC adapter by using the power cord with the earthing terminal.
2. The security function might work for safety when the voltage and the frequency outside the specification range are input to the AC adapter and the AC adapter stop operating. In this case, it is necessary to exchange AC adapter for a fee. Please contact our maintenance service center.
3. Please arrange the AC adapter to pull out the power cord immediately in the emergency. (Do not arrange the AC adapter out of reach.)



Battery operation

Please install battery pack (BU-11/11S) in the battery pack slot of TYPE-Q101-CA+. Turn off the splicer and disconnect the AC adapter before installing and removing the battery pack.

*Please confirm the charge before the battery pack is installed.
(Please refer to the page 2-4 “battery level check”)

Battery pack installation

Please insert the battery pack up to foundation of battery pack slot surely and vertically.



Battery pack removal

Open the lid of the battery pack slot, then hang the finger on the projection of the battery pack, and draw out the battery pack in the direction of the arrow.

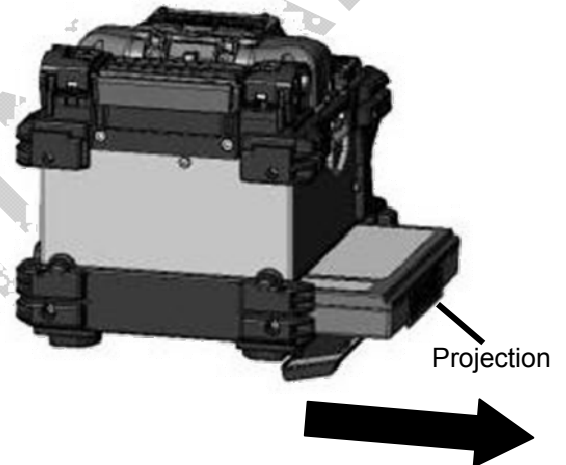

How to open and close the lid of battery pack slot

<Open> Release the lock by moving the lock in the direction of the arrow, then open the lid.

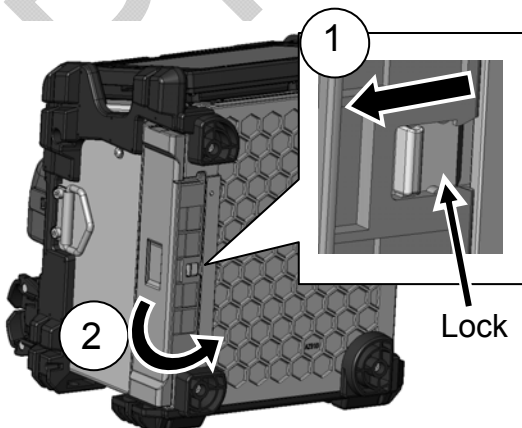

<Close> Insert tabs of the lid into the battery pack slot, close the lid and move the lock in the direction of the arrow.

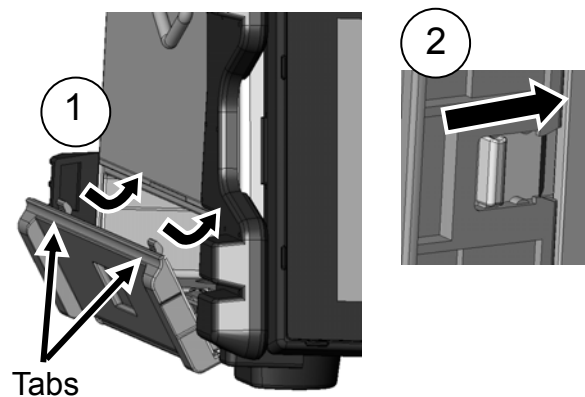

Battery level check

Press the battery check button. The LED will light up for a few seconds to indicate the battery status in one of four levels.

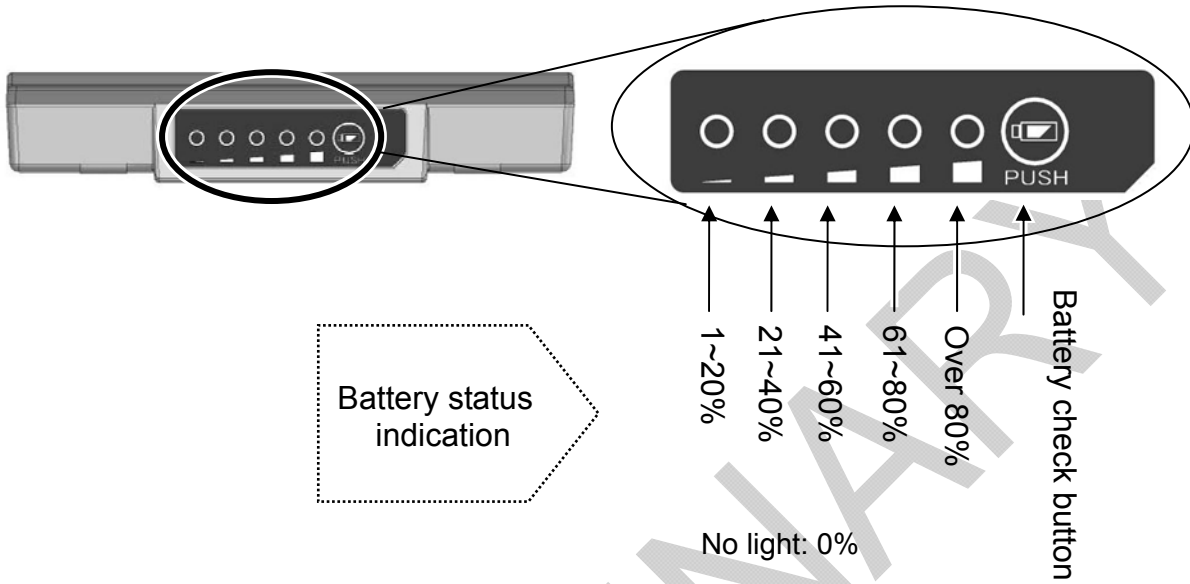

Indicator	Meaning
	Battery remains enough. Over 80%
	61 to 80%
	41 to 60%
	21 to 40%
	Battery remains little. 1 to 20%
	No battery. Please charge the battery immediately.
	Charging. Icon changes depending on the battery level.

The battery level is also displayed as a battery level indicator on the monitor.

Splice and heat cycles possible with remaining battery level is indicated when you touch the indicator.

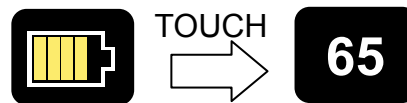

*The frequency is estimated by the battery level. It changes according to the operational environment and condition.
(No guaranteed value)

*Be sure to charge the battery before use when the battery level is low.

*There is no battery indicator when AC adapter is in use.

Battery charging

1. Insert the battery pack into the TYPE-Q101-CA+.
2. Connect the AC adapter with the TYPE-Q101-CA+.
3. LED (green) on the side of the DC input terminal blinks, and the charge begins.
4. It takes 2 - 3 hour to finish charging though it changes according to the residual quantity of the battery. LED (green) lights when the charge ends.

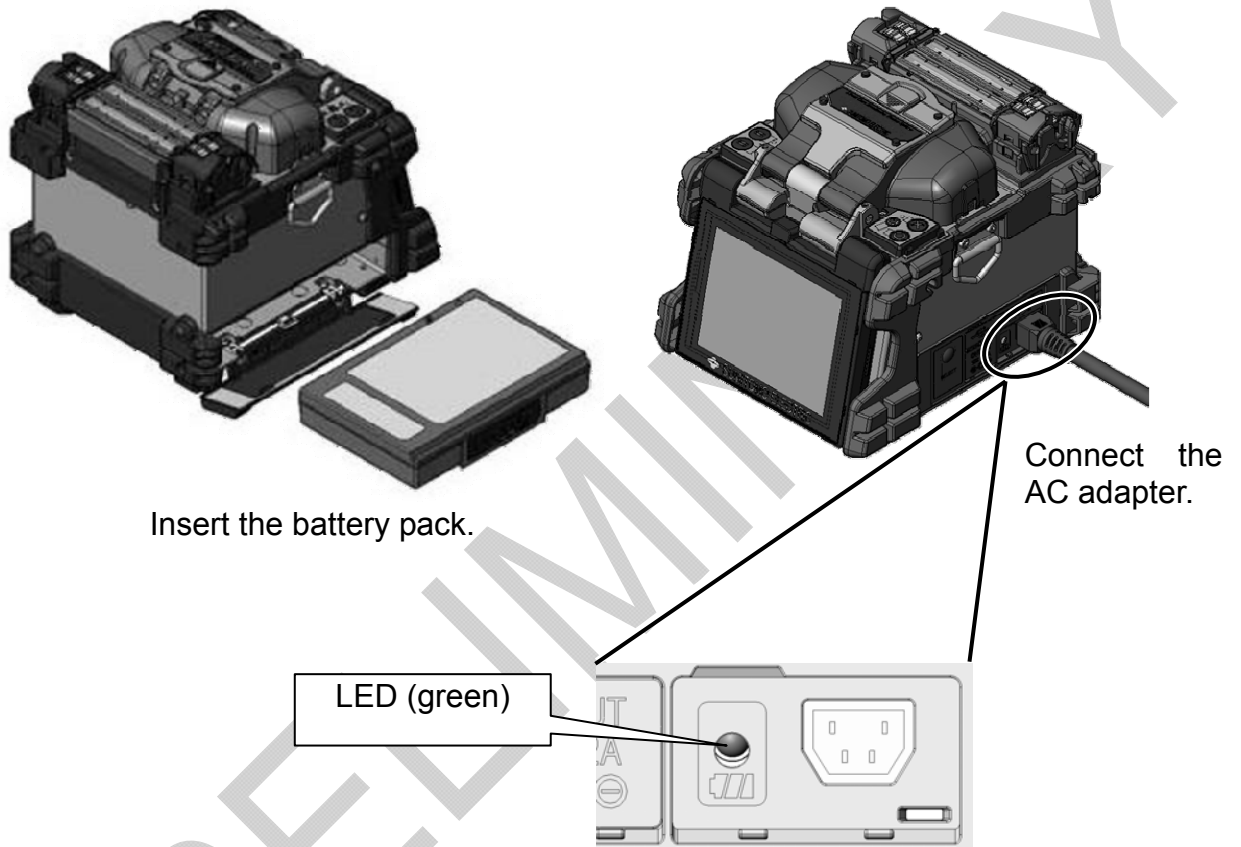

•The battery pack can be charged while the splicer is in using. However, it takes a longer compared with the time when the splicer is powered off. (It takes about 14 hours.)



•Please charge the battery in the following temperature span. The battery pack might be deteriorated (decrease in capacity) at the temperature that exceeds this range.

***Temperature range for charging: 0°C~+40°C**

DC operation (car battery)

The car battery cable PCV-11 (option) is required to operate the splicer on DC power (car battery). Contact a sales representative.

Precautions for battery pack

- **Before using the battery pack for the first time, charge the battery pack. (The battery is not fully charged before shipping.)**
- The battery pack is a consumable. Repeated charging and discharging decreases battery life.
- Store the battery pack within the following temperature range. Failure to do so may lead to deterioration in performance.
 - *Battery pack storage temperature range:
 - 20°C ~ +50°C (if stored for less than 1 month)
 - 20°C ~ +40°C (if stored for less than 3 months)
 - 20°C ~ +20°C (if stored for less than 1 year)
- Do not use or store the battery pack at high temperature, such as in strong direct sunlight, in cars during hot weather. This may cause leakage of battery fluid.
- If you are not going to use the battery pack for a long period, charge the battery pack once every 6 months.
- If you are not going to use the splicer, remove the battery pack from the splicer.

When should the battery be replaced?

When the splice frequency decreased extremely with fully charged battery, please purchase a new battery pack.

When disposing of the battery pack, contact our maintenance service center or follow the local regulations.

Operating procedures

Turning on the TYPE-Q101-CA+

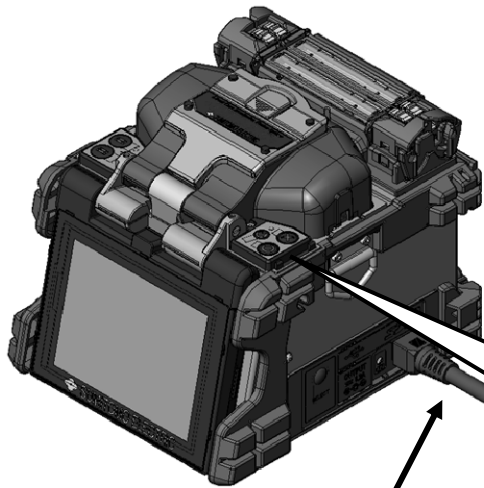

Output cord of the AC adapter

The monitor viewing angle can be adjusted.

- 1: Ensure that the electrodes are fully inserted in the splicer.
- 2: Insert the output cord of the AC adapter into the DC input terminal.
- 3: Adjust the monitor for optimum viewing angles.
- 4: Press the power () key for more than 1 second to turn on the power.

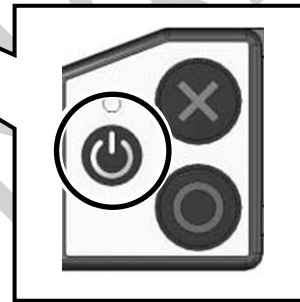

If you press the power key right after connecting the power cord to the power supply module, it may take a few seconds until the splicer is powered on.

Special note on monitors

Although bright spots or dark spots may appear on the screen, this is a unique characteristic of liquid crystal displays, and such do not constitute or imply a machine defect.

Initial screen

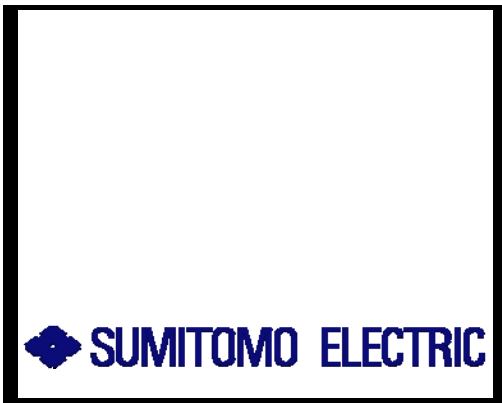

Startup screen

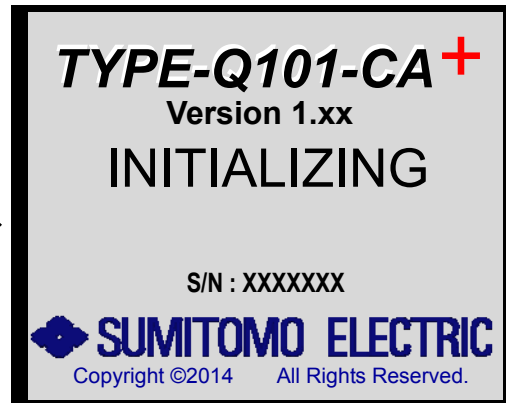
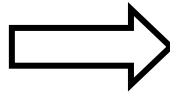

Initialize screen

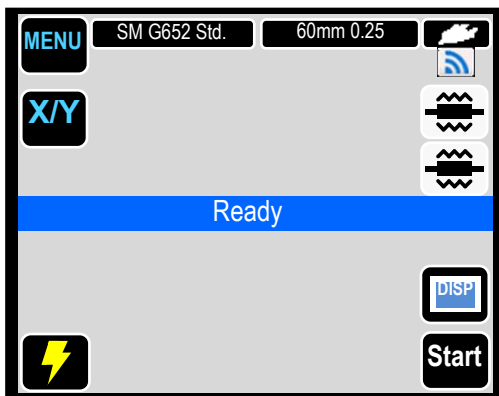

Initialization is complete.
→ Ready screen

Each motor of the splicer is initialized after turning on the power supply, and the ready screen is displayed after a few seconds. TYPE-Q101-CA+ has the touch screen function that enables to operate by the icons on the screen.

The function of each icon in the ready screen is as follows.

MENU : Display the main menu screen where various functions are selected.

SM G652 Std. : Showing splice program that is selected. You can go to splice program selection screen by touching it. Please refer to page 4-1 for the setting method of the splice program.

60mm 0.25 : Showing heater program that is selected. You can go to heater program selection screen by touching it. Please refer to page 4-2 for the setting method of the heater program.

X/Y : Select microscope

 : Indicator of power input (AC or battery)

 : Arc test

 : Display/Non-display icons

Start : Start splice

 : Start and cancel heating cycle

 : Wireless LAN connection

Stripping the fiber coating / Cleaning the bare fiber

- 1: Clean the fiber coating thoroughly to remove cable gel or other stains.
- 2: Strip the fiber coating. (An example shows use of Sumitomo JR-M03 tool, strip length shown apply to any stripping tool. If you use another jacket remover, please refer to its operation manual.)
Use the correct groove of the remover suitable for the fiber coating diameter.
→ See figure <1>.

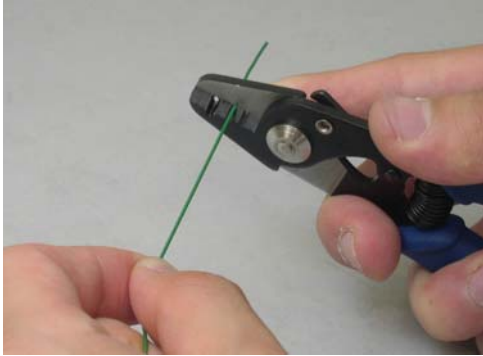

- 3: Strip Approx. 30~40mm of the fiber coating with the JR-M03 (ex).
(If you use another remover, please refer to its operation manual.)

*If the stripping length is too long, the fiber cleaver may not store the off-cut in the off-cut collector.

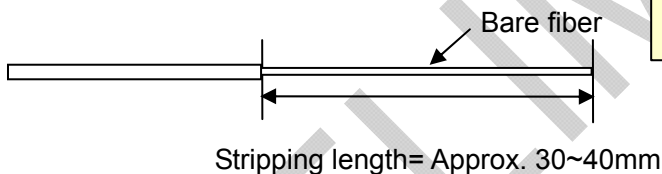

<1> Check the fiber coating diameter.

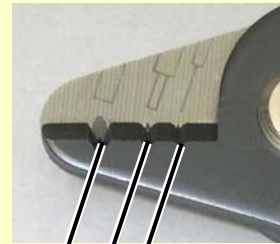

(1) (2) (3)

- (1) Fiber coating diameter : 1.6-3mm
- (2) Fiber coating diameter : 600-900 μ m
- (3) Fiber coating diameter : 250 μ m

The JR-M03 strips approx. 25mm of fiber coating at a time. To strip 30~40mm of the fiber coating, repeat the operation.

- 4: Repeat the stripping process for the other fiber.
- 5: Clean the bare fiber from the end of the fiber coating with a lint-free gauze pad moistened with pure alcohol. Pull the bare fiber through the gauze pad. Rotate the fiber by 90 degrees to remove any coating residue. Do not reuse the gauze pad that was used.

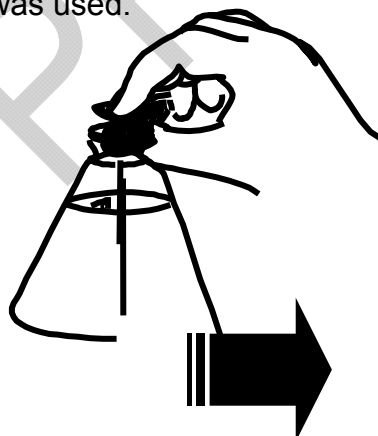

Keep the fiber squeaky clean.

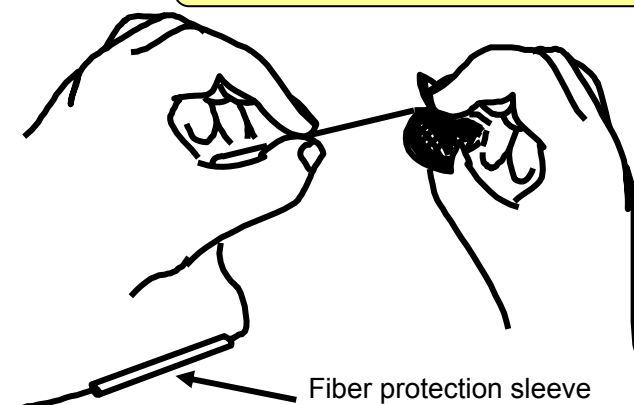

Cleaving the fiber

Cleave the fiber. (An example shows use of Sumitomo FC-6S cleaver, cleave length shown apply to any cleaving tool. If you use other models of cleavers, please refer to the operation manual.)

Applicable cleave length: 5mm-20mm (ϕ 0.25mm), 10-20mm (ϕ 0.9mm)

*A maximum cleave length for the TYPE-Q101-CA+ is 16mm.

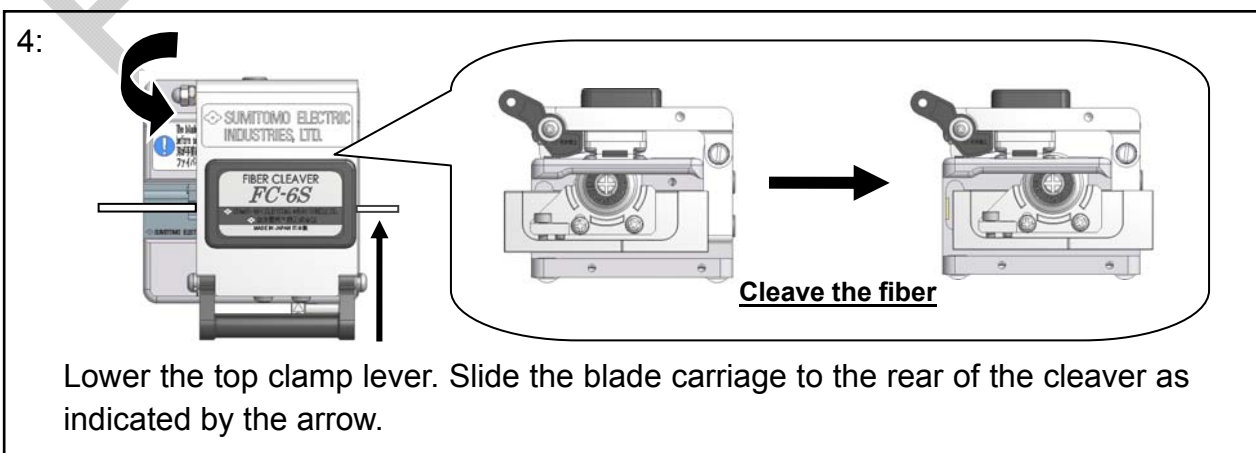
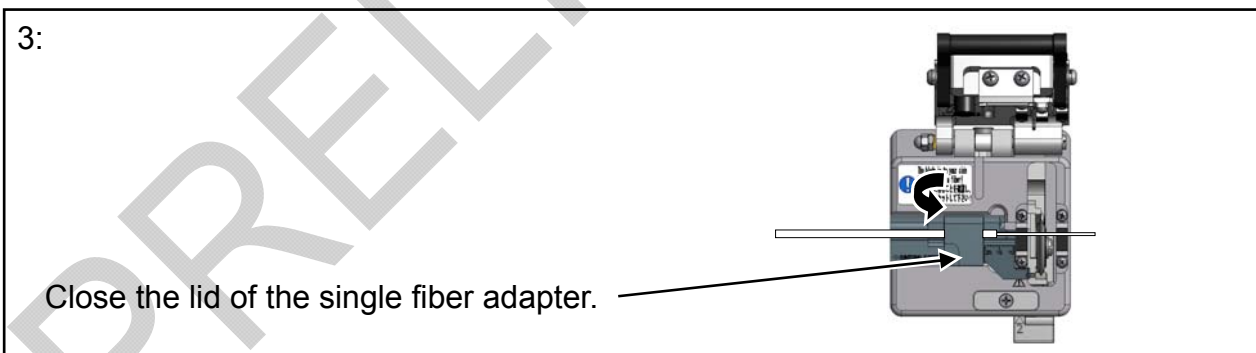
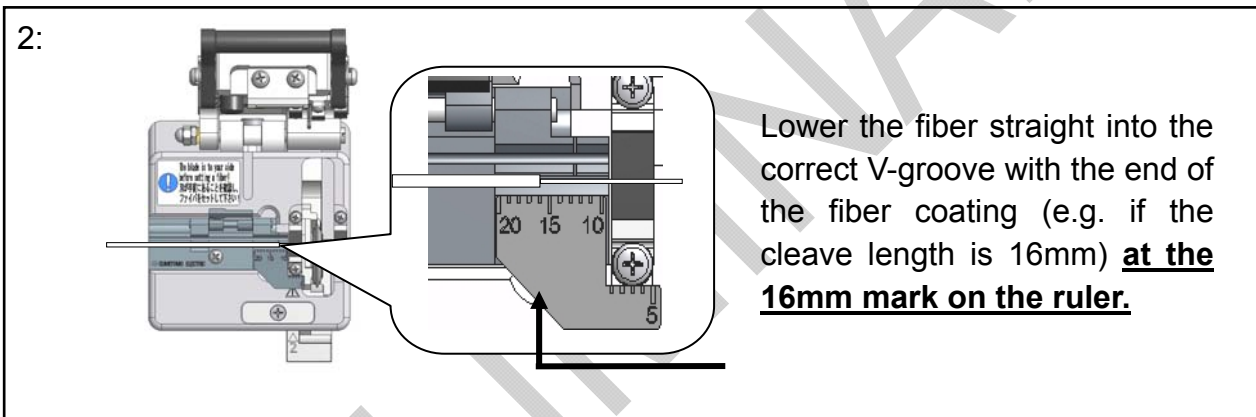
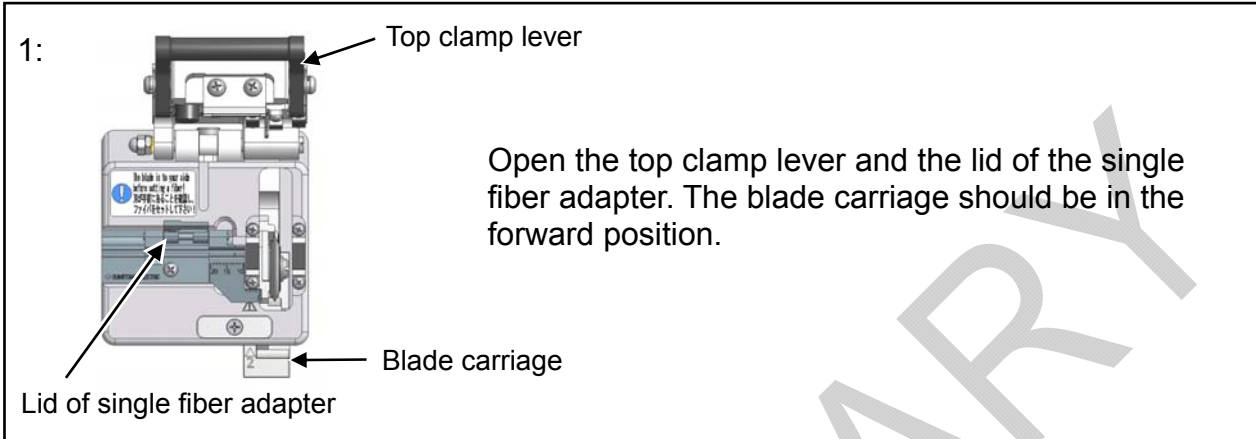

- 5: Open the top clamp lever.
Then open the lid of the single fiber adapter and lift the newly cleaved fiber. Lift the off-cut and dispose it properly.

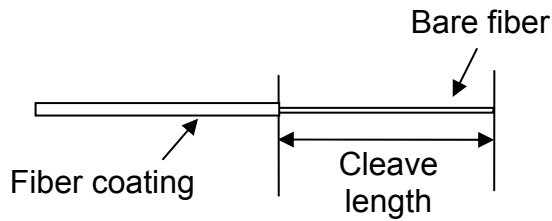

- 6: Insert the fiber into the splicer.



1. Do not re-clean the fiber after cleaving.
2. To avoid damaging or contaminating the delicate fiber ends, insert each fiber immediately after preparation.
3. Glass-fiber fragments are extremely sharp. Handle with care.

•By using fiber cleaver (FC-6S-5C), cleaving length of 5-20mm is available (ϕ 0.25mm & ϕ 0.9mm). Please confirm the manual of fiber cleaver (FC-6S-5C) about detail procedure.

Inserting fibers into the splicer

1: Open the hood.

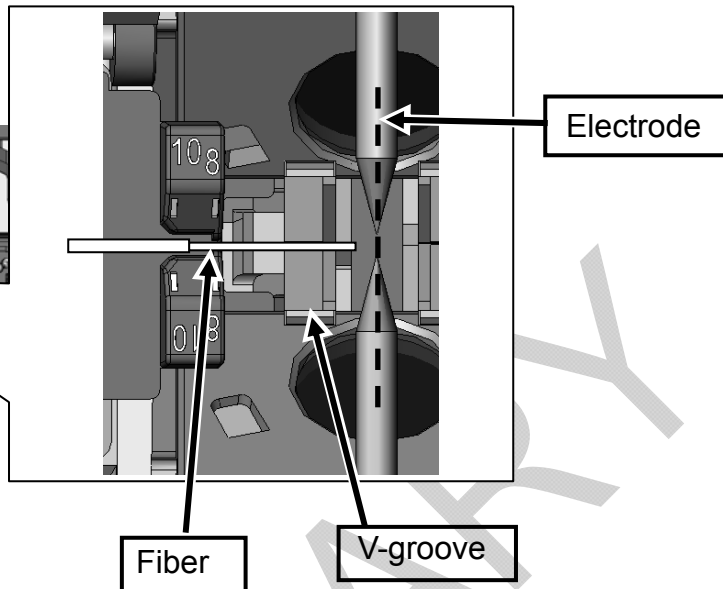
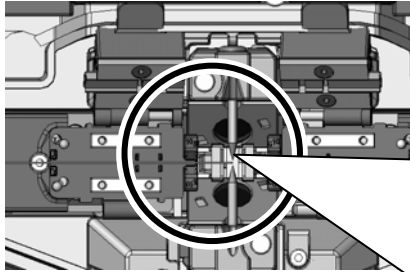

2: Set the fiber end between the edge of v-groove and the electrode.

3: Close the fiber coating clamp lid.

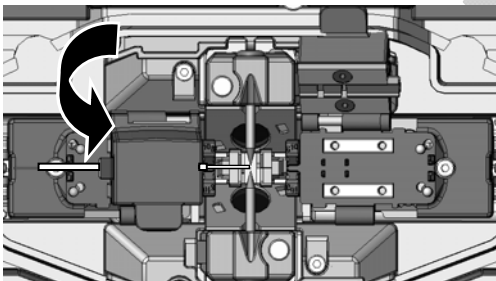

Do not touch the fiber end face against any surface.

4: Repeat step 1 to 2 for the other fiber.

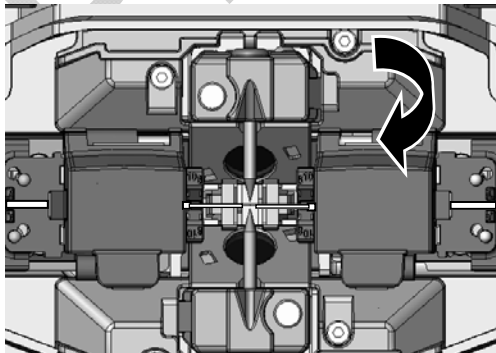

5: Close the hood.

6: Start an arc test or the splicing process.

Arc test

The fusion splicing is a method of melting and connecting the point of the optical fiber by heat of electrical discharge. Because optimum arc conditions are different depending on environment (atmospheric pressure and temperature) and the electrode condition (wear-out and adhesion of the glass) and the optical fiber (manufacturer and SMF/MMF, etc.), appropriate arc condition is necessary to make a low splice loss. Please perform the arc test before splicing in the typical splice program such as “SMF Standard”. In the Auto mode, TYPE-Q101-CA+ analyzes the arc and has the function to calibrate the arc condition automatically at each splice. Therefore, arc test is not needed usually in the Auto mode.

As an exception, perform an arc test in the following situations to calibrate the arc power and position.

- Poor splice performance
(high or inconsistent splice losses, poor splice strength)
- After electrode replacement
- Extreme changes in temperatures, humidity or air pressure

Arc test procedure

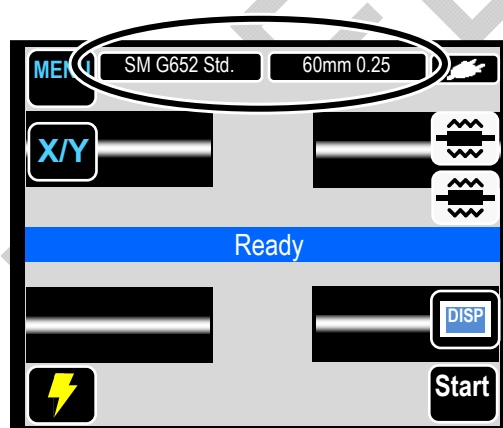

- 1: Set each fiber that has been prepared. (The coating is removed and fiber is cleaved.)
- 2: Confirm whether the splice program and heater program is correct on the ready screen.

About setting and changing the programs, please refer to the page 4-1 and 4-2 “Splice and heater programs setting”.

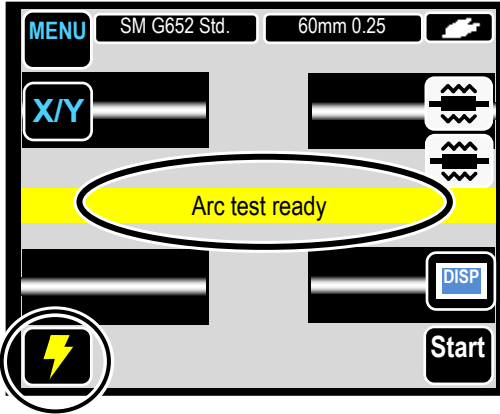

3: Touch the “Arc test” (⚡)

4: “Arc test ready” screen will be displayed.

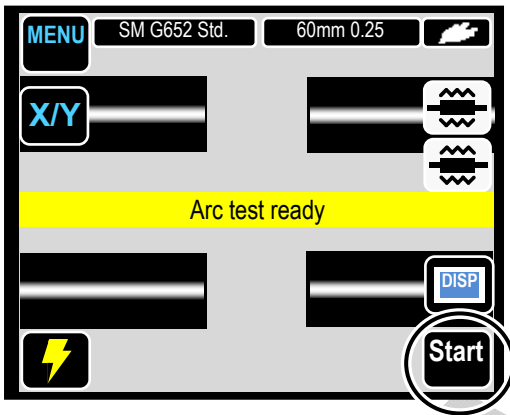

5: Touch the “Start” (Start) or push (●).

6: An arc test is started. Fibers are not spliced because it is not moved on the arc test.

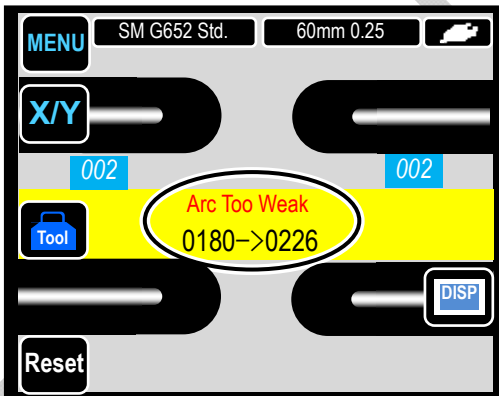

7: If “Arc Too Weak”, “Arc Too Strong” or “Arc Center” is displayed, prepare the fiber again and repeat the test until “ARC OK” is displayed.

The melt back distance of the left and right fibers and the arc center position which are measured via image processing are displayed on the monitor screen. (The arc center position is displayed only if the position is shifted.)

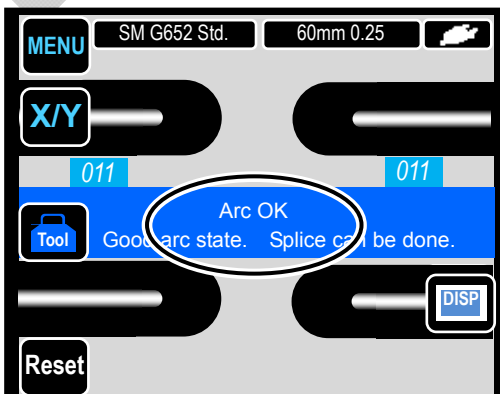

8: If “Arc OK” is displayed, begin the fiber preparation procedure to perform a splice. The splicer automatically initializes when the hood is opened.

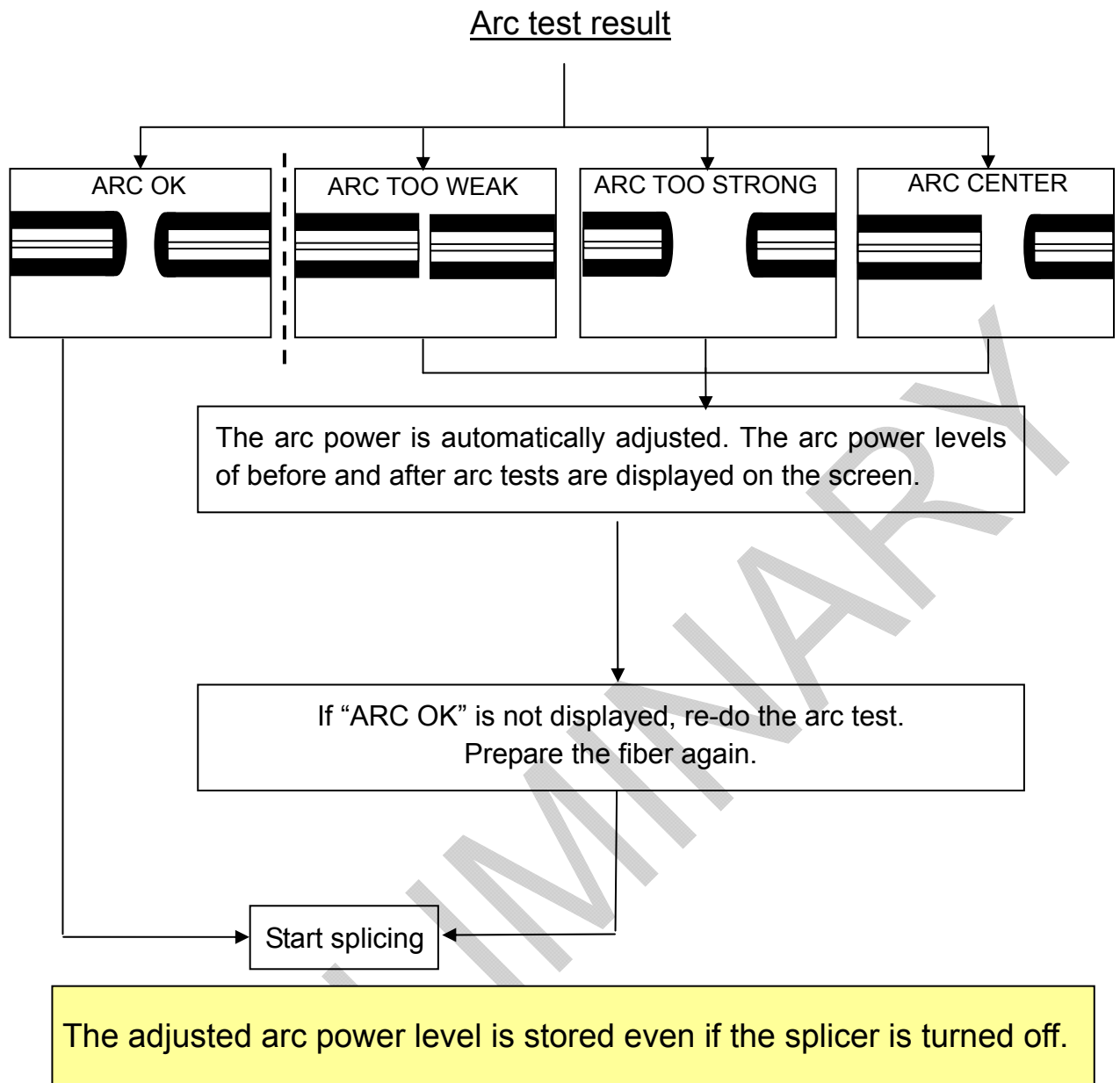

Fiber preparation

- 1: Be sure to slip the fiber protection sleeve over one of the fibers to be spliced before stripping and cleaving the fibers. The fiber protection sleeve cannot be installed after splicing.
- 2: Strip the fiber coating and clean the bare fiber.
Refer to page 2-9.
- 3: Cleave the bare fiber to proper cleave length.
Refer to page 2-10.
- 4: After setting the prepared fibers on TYPE-Q101-CA+, splicing starts by touching "Start" (Start) or pushing (Start). (Please refer to the next page.)

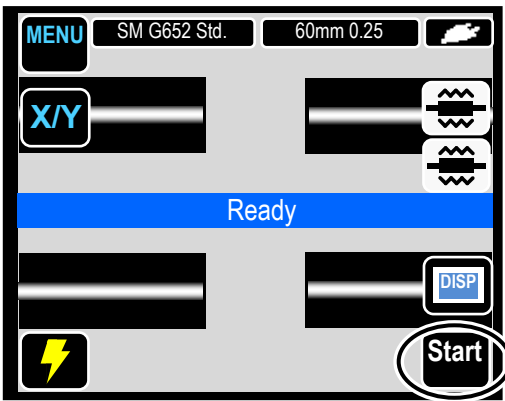

Touch the "Start".

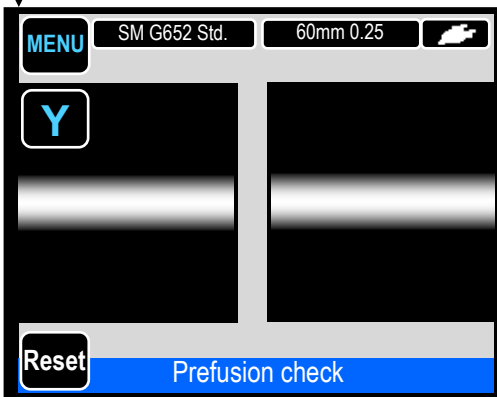

Inspection of fiber end face & dust

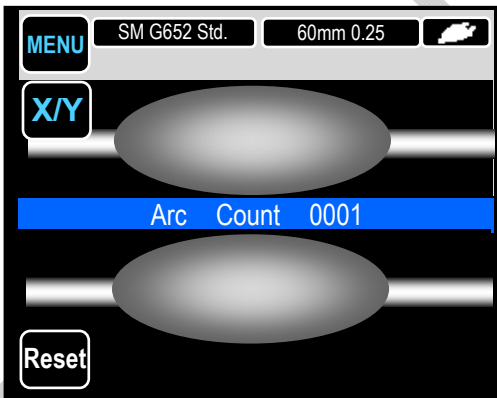

Arc is generated.

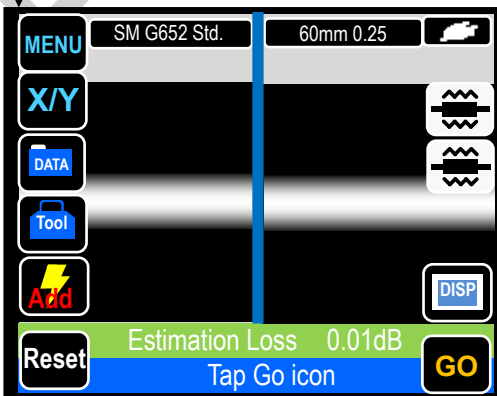

Estimated loss is displayed.

See the next page if you skip the checking of splice data and go on to the next step.

Checking splice data

• After a splice, touch the "Data" ().

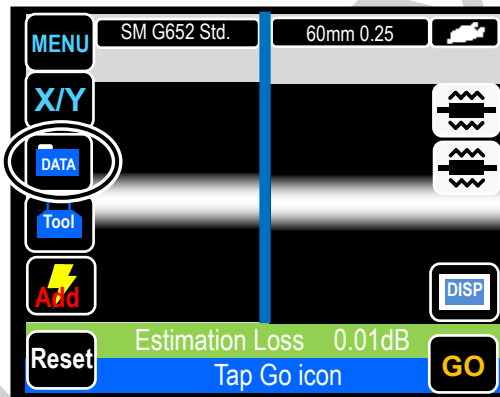

Confirm splice data.

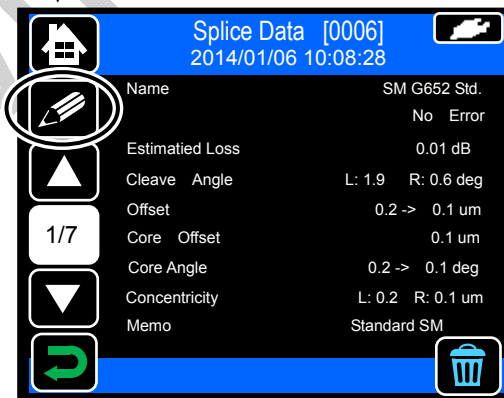

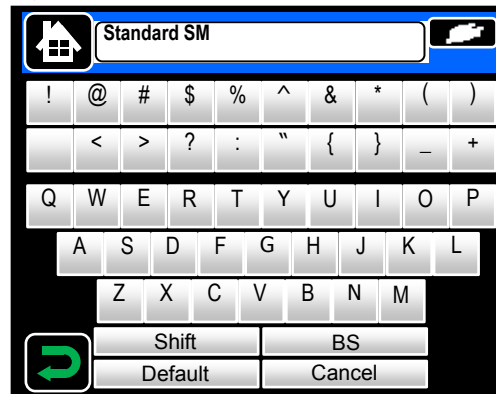

Add the memo by touching "MEMO" ().

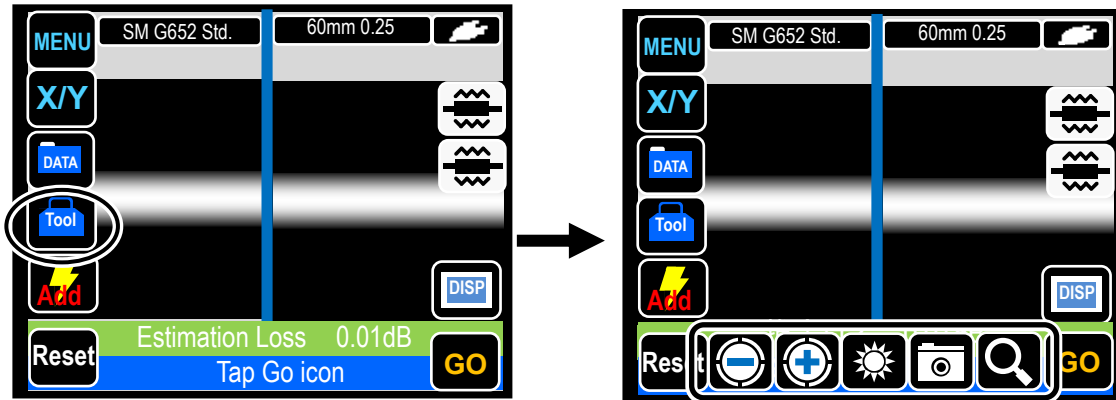

See the next page if you skip the checking of splice image and go on to the next step.

Checking splice image



Touch the “Tool” () after splice process completed.

Icons of checking tools are displayed.

Checking Tools



: By touching an arbitrary place of the image, the part is expanding displayed.



: Save the image to SD card or internal memory.



: Change the brightness of the image.



: Change the focus of the image.



Proof test

(if automatic proof test is selected)

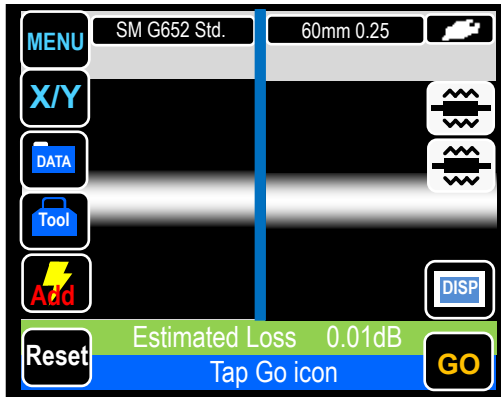

Open the hood.

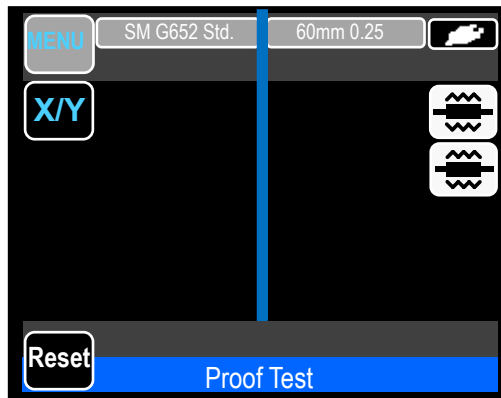

The proof test is automatically started.
(The test cannot be canceled once started.)

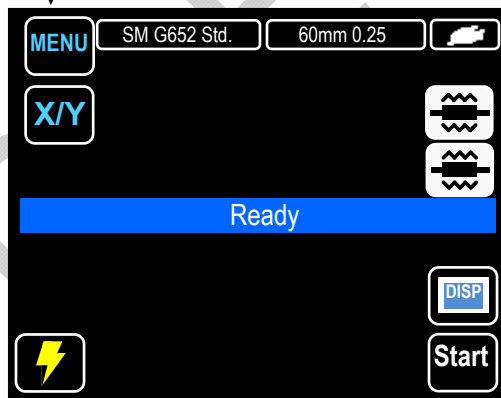

Remove the spliced fiber when the screen above is displayed.

(if manual proof test is selected)

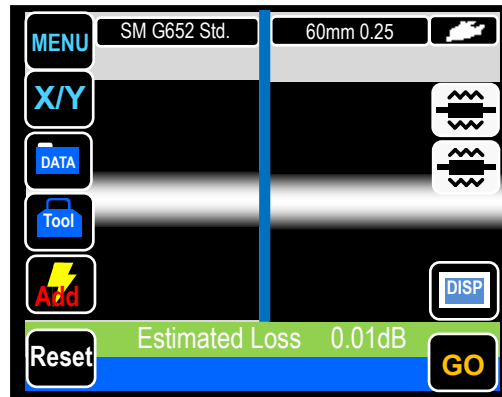

Touch "GO".

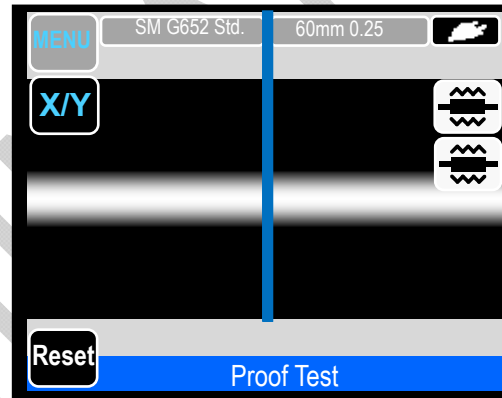

The proof test is started.
(The test cannot be canceled once started.)

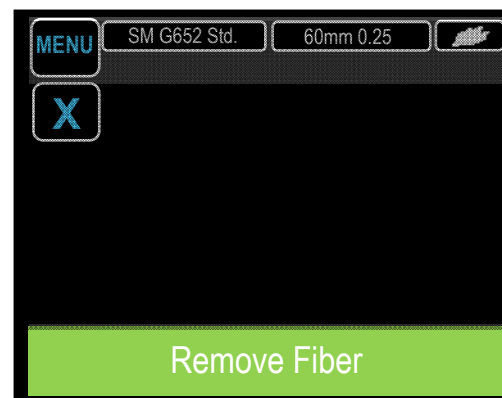

Open the hood and remove the spliced fiber when the screen above is displayed.

Take care to keep the spliced fiber straight. Do not flex it back and forth. Doing so will cause the spliced fiber to be broken, resulting in loss of the long term reliability of the fiber.

Evaluating splice quality

If the spliced fiber is as follows or estimated losses are high, re-do the entire splice.

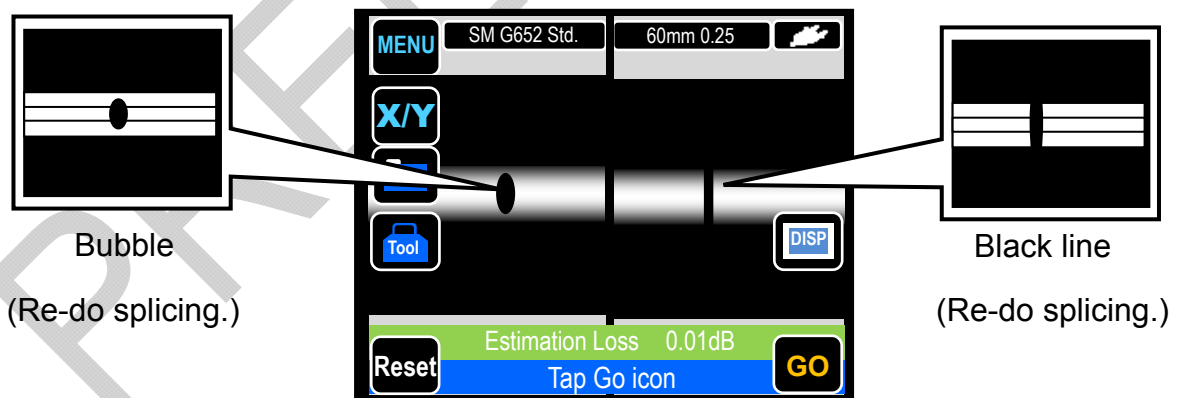
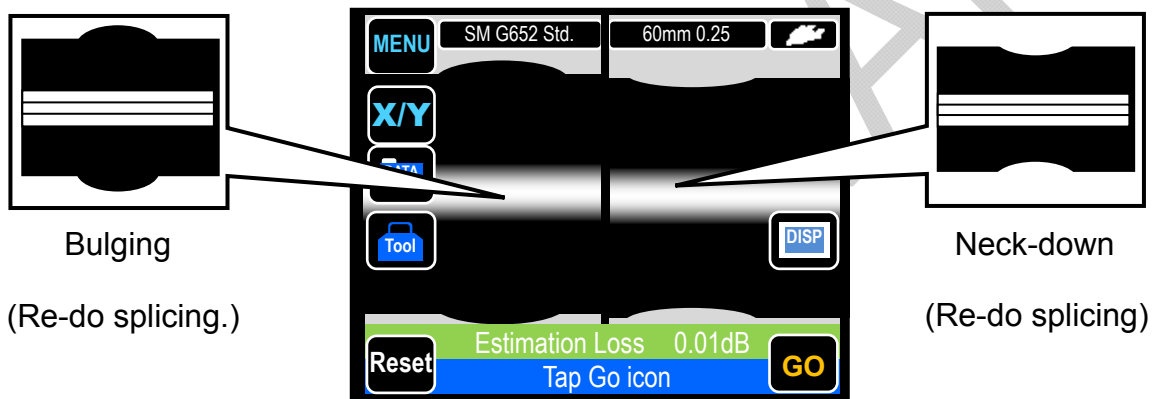
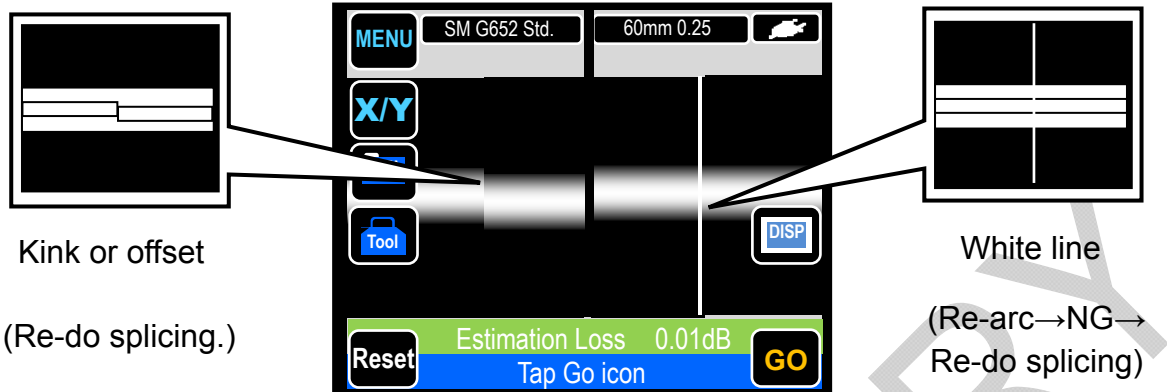

After MMF or dissimilar fiber splicing, a line sometimes appears at the splice point. But it does not affect splice quality, such as splice loss, tensile strength, and etc.

Splice protection

- 1: Open the heat shrink oven lid and the heat shrink oven clamps.
Open the hood and the fiber coating clamps to release the spliced fiber.
- 2: Make sure that the fiber protection sleeve is centered over the spliced portion of the fiber.

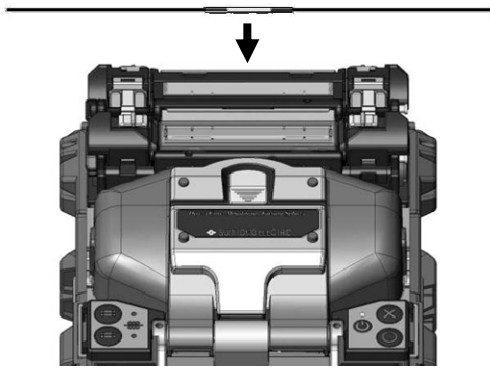

The applicable fiber protection sleeves vary depending on the cleave length. For more information, refer to page 1-4.



- 3: While maintaining a slight tension on the fiber end, lower the fiber onto the heat shrink oven and push down.

- Do not twist the fiber.
- Do not flex the fiber.

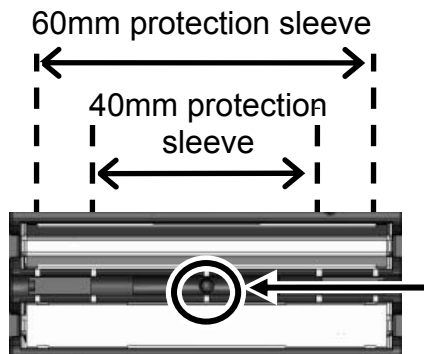
- 4: The 2 heat shrink oven clamps and the heat shrink oven lid are closed.
When lowering the fiber onto the heat shrink oven, use the markings on the heat shrink oven as a reference.



Marking for the center of the heat shrink oven

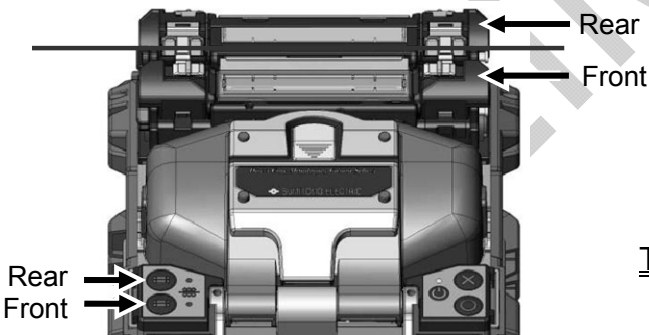

- 5: Touch "heat" icon () on the screen or press heat key ().
The heat cycle is started.

If Auto start heating is set to ON, the heating operation is automatically started when the fiber is placed into the heat shrink oven.

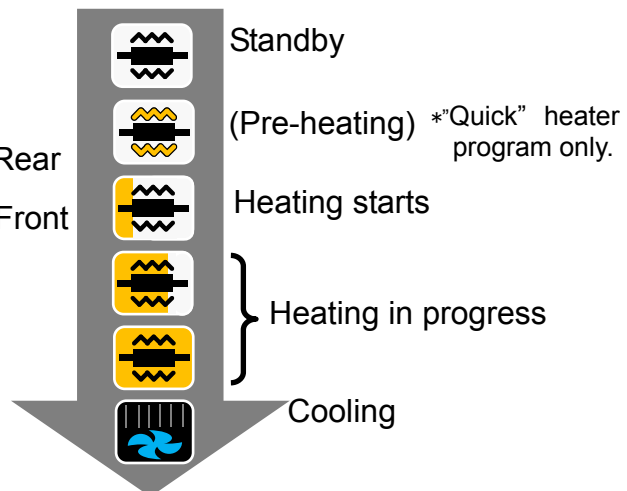
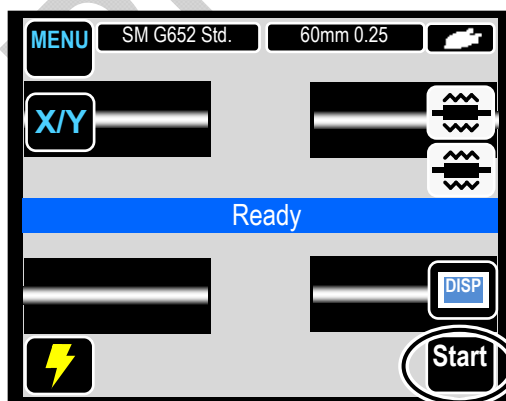

The heat icon changes as follows.



If you would like to cancel the heating process, press the  (HEAT) key or touch "heat" () again.

- 6: The splicer gives a beep sound indicating completion of the heating cycle. Take out the sleeve from the heat shrink oven after a beep sound is heard.
- 7: Place the protection sleeve onto the cooling tray.

 Caution

The protection sleeve can be taken out from the heat shrink oven after a beep sound is heard. Also finish of heating cycle can be confirmed by the heat icon's change. If the sleeve is taken out from the oven before heat cycle completed, the splice loss might increase because the less cooling cause fiber bending or twisting. Please wait for the finish of heating cycle.

<Cooling tray installation>

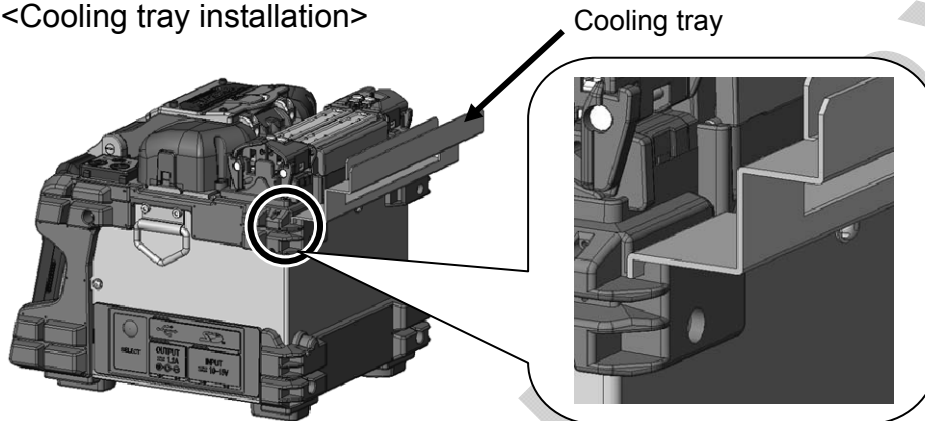



Install the cooling tray into the splicer as shown above.

 Caution

After the heat cycle is complete, the fiber protection sleeve may be hot. Handle with care.
 Never touch the surface of the heating plate during the heating operation. Doing so may cause personal injury and damage to the heat shrink oven.

NG Evaluating protection sleeve

NG

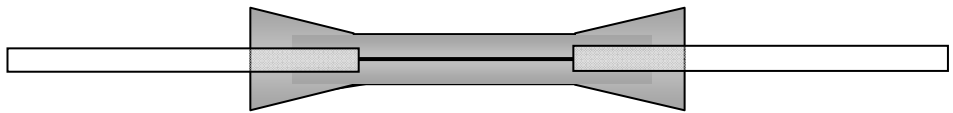
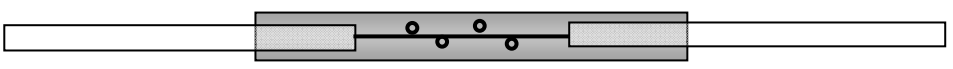
- 1: The shrinking sleeve is not centered over the splice.
 
- 2: Bend in bare fiber
 
- 3: Incompletely shrunk (trumpet end)
 
- 4: Bubbles on bare fiber
 

Drop cable splicing

Applicable cable

- Tight buffer type single fiber drop cable.

Required items

- Fusion splicer (TYPE-Q101-CA+)
- Allen key 1.5 (included in fusion splicer kit)
- Cross-recessed screwdriver
- Nippers
- Jacket remover
- Fiber cleaver
- Fiber holders for drop cable

Preparation

<Fusion splicer>

- Using the Allen key, remove the fiber coating clamp from the splicer.

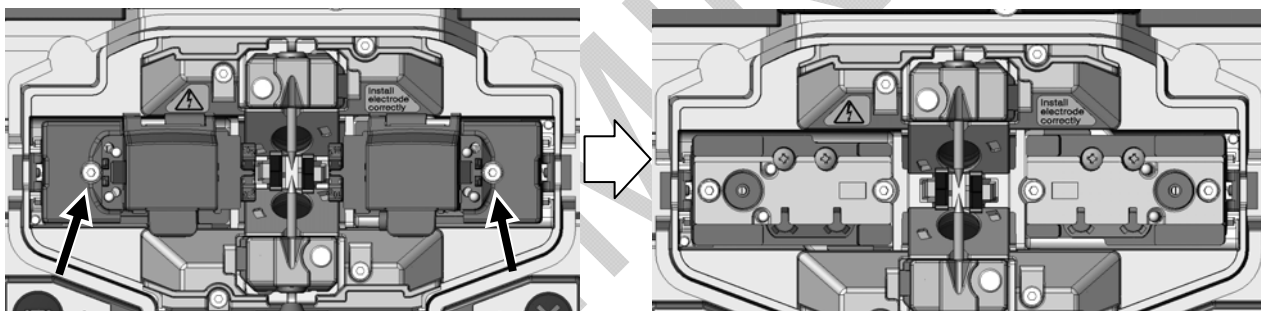

Factory default

Fiber coating clamp is removed.

<Fiber cleaver>

- If the single fiber adapter AP-FC6M is attached to the cleaver, it must be removed.
- If the single fiber adapter AP-FC6SA is attached to the cleaver, it does not need to be removed and can be used as it is.

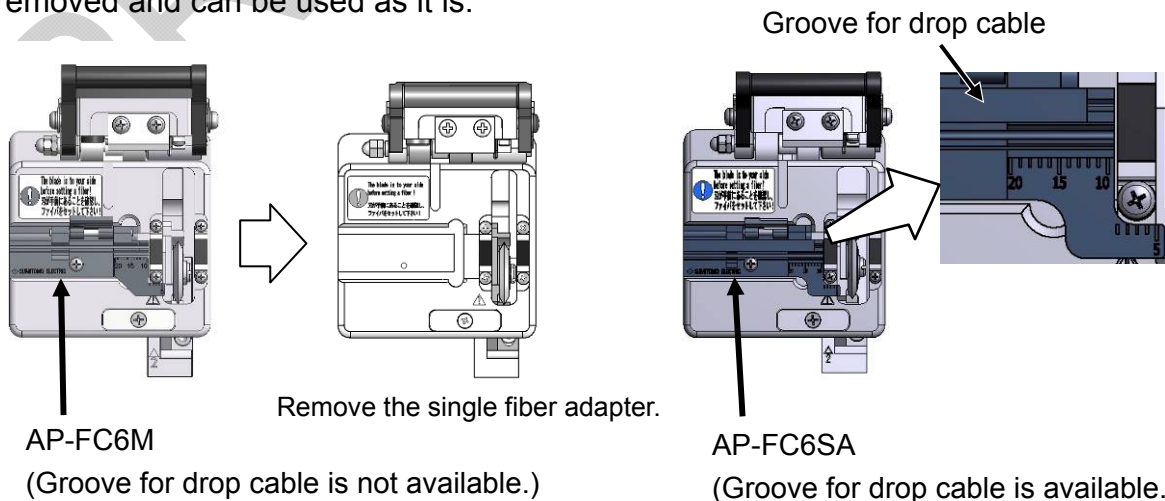

AP-FC6M

(Groove for drop cable is not available.)

Remove the single fiber adapter.

AP-FC6SA

(Groove for drop cable is available.)

Removing cable sheath

Clean the cable sheath thoroughly to remove cable gel or other stains.



1. Separate the steel wire from the cable using nippers.



2. Cut the steel wire to a desired length.

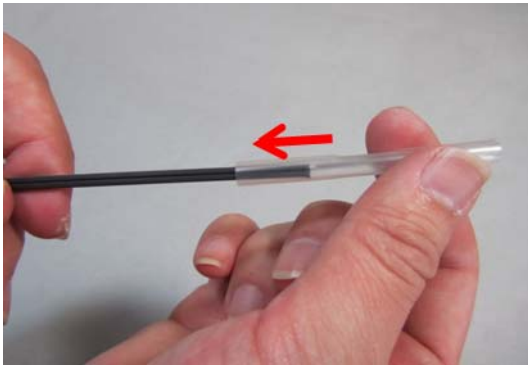

3. Insert a protection sleeve over the cable.



4. Make a slit along the groove of the cable sheath using nippers.

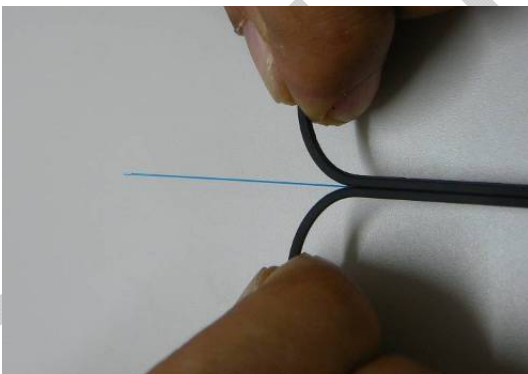

5. Split the cable sheath to expose 30~40mm of optical fiber. Cut off the split cable sheath.

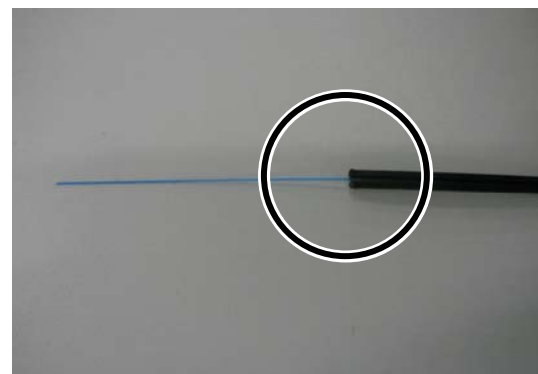

6. The cable sheath is removed. Repeat step 1 to 5 for the other cable.



Caution

Take care not to damage the optical fiber when cutting the cable sheath.



Cut each half of the cable sheath to the same length.

Fiber preparation procedures 1 (AP-FC6SA is available)

This section outlines fiber preparation procedures in using a fiber cleaver with a single fiber adapter (AP-FC6SA). If your fiber cleaver does not have the single fiber adapter or a single fiber adapter attached to your cleaver is AP-FC6M, please refer to the procedures 2.

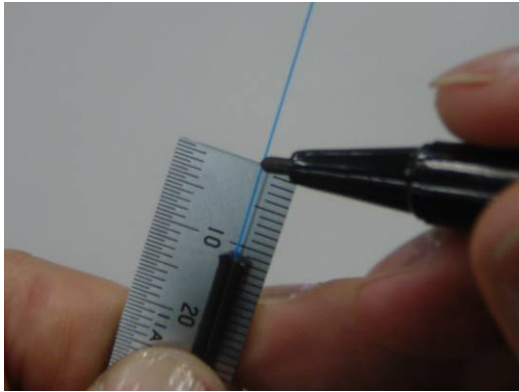

1. Put a mark at 10~12mm away from the cable end.

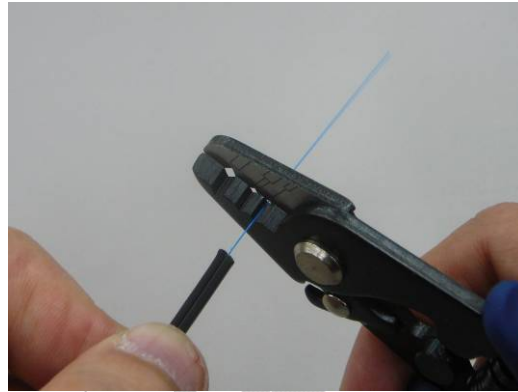

2. Remove the fiber coating from the mark using a jacket remover.



3. Clean the bare fiber from the end of the fiber coating with a gauze pad moistened with pure alcohol. Pull the bare fiber through the gauze pad and rotate the fiber to remove any coating residue.

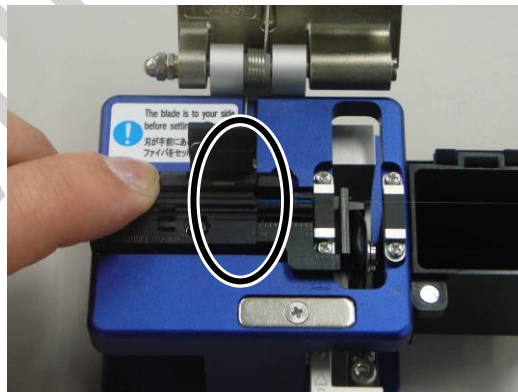

4. Place the cable in the groove for drop cable on the cleaver, aligning the cable end with the end of the single fiber adapter. Cleave the fiber referring to the cleaver instructions.

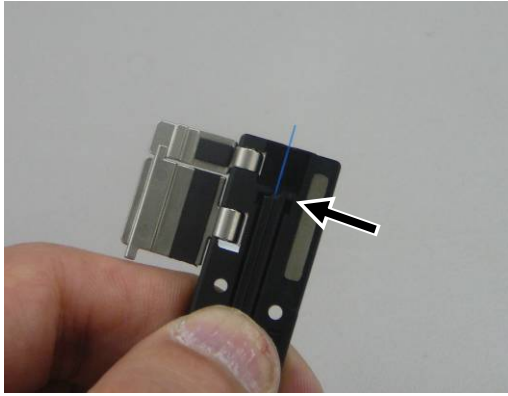

5. Load the cable in the fiber holder. Make sure that the cable sheath touches the groove. Close the bigger lid of the holder first.



6. Repeat step 1~5 for the other cable.

PRELIMINARY

Fiber preparation procedures 2 (AP-FC6SA is not available)

This section outlines fiber preparation procedures in using a fiber cleaver without single fiber adapter (AP-FC6SA). If AP-FC6SA is available, please refer to the procedures 1.

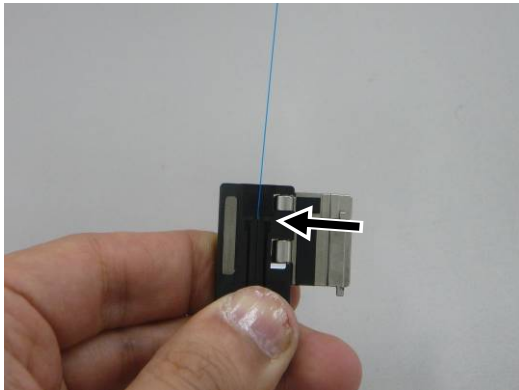

1. Load the cable with its sheath removed in the fiber holder. Make sure that the cable sheath touches the groove. Close the bigger lid of the holder first.



2. Remove the fiber coating at 2~4mm away from the edge of the fiber holder. (Touch the JR-M03 against the edge to remove, and you can remove the coating at 3mm away from the edge.)



3. Clean the bare fiber from the end of the fiber coating with a gauze pad moistened with pure alcohol. Pull the bare fiber through the gauze pad and rotate the fiber to remove any coating residue.

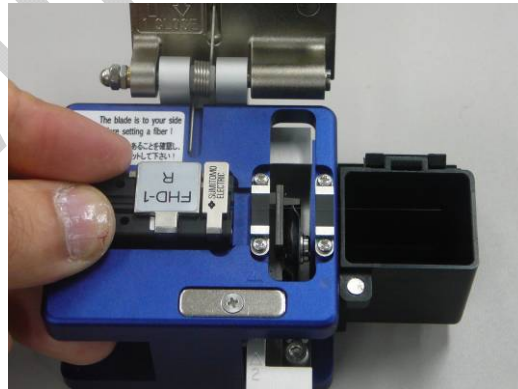

4. Place the fiber holder in the cleaver, touching the edge of the fiber holder against the edge of the fiber holder receptacle. Cleave the fiber referring to the cleaver instructions.

5. Repeat step 1~4 for the other cable.



Inserting the fiber into the splicer

1. Open the hood.
2. Place the fiber holder onto the fiber holder stage, fitting the pin of the stage into the hole of the fiber holder.



Take great care not to touch the fiber end face against any surfaces.

3. Make sure that the fiber sits in the V-groove correctly.

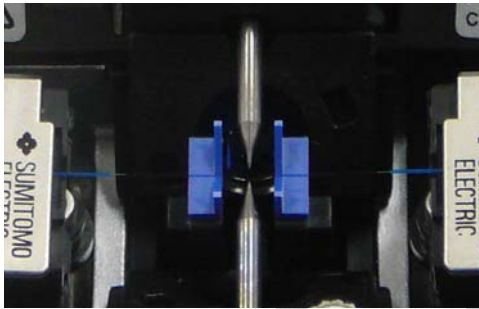

4. Close the hood.
5. Start the splicing process.
(Note: Perform an arc test prior to splicing.)

Splice protection

1. Open the oven lid and oven clamps. Open the hood and all lids of the fiber holders. Make the left hand oven clamp linked with the oven lid and the right hand oven clamp independent.
2. Take out the cable and slide the fiber protection sleeve onto the fiber. Make sure that the protection sleeve is centered over the splice and at least 5mm of the sleeve overlaps the cable sheath at each end of the splice.

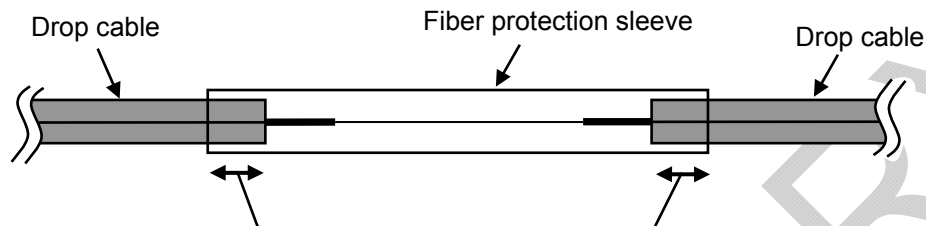

At least 5mm of the sleeve must overlap the cable sheath at each end of the splice.

3. While maintaining a slight tension on the cable ends, transfer the cable to the heat shrink oven and close the right hand oven clamp.

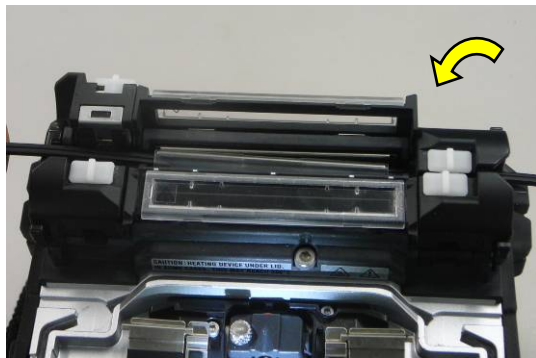

Pay attention not to bend and flex the cable. Failure to do so can cause the splice to break.

4. While applying a slight tension to the cable end, close the left hand oven clamp and oven lid. Start the heat shrink process.

5. After the heat shrink process is complete, open the oven lid and oven clamps and take out the cable.

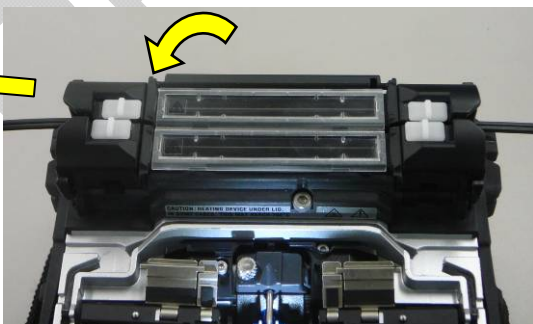

While maintaining a slight tension on the cable ends, close the oven clamps.

PRELIMINARY

3. Daily cleaning and checking up

To keep excellent splice quality, regular cleaning and inspection are required. Especially cleaning should be performed before and after each use. We recommend your splicer to be checked through our maintenance service once a year.



Turn off the TYPE-Q101-CA+ before maintenance work. Failure to do so may cause electric shock.

Cleaning

Clean each part with a cotton swab. Please bear in mind that daily cleaning can maintain splicer performance. Clean components before and after use.

Names of components

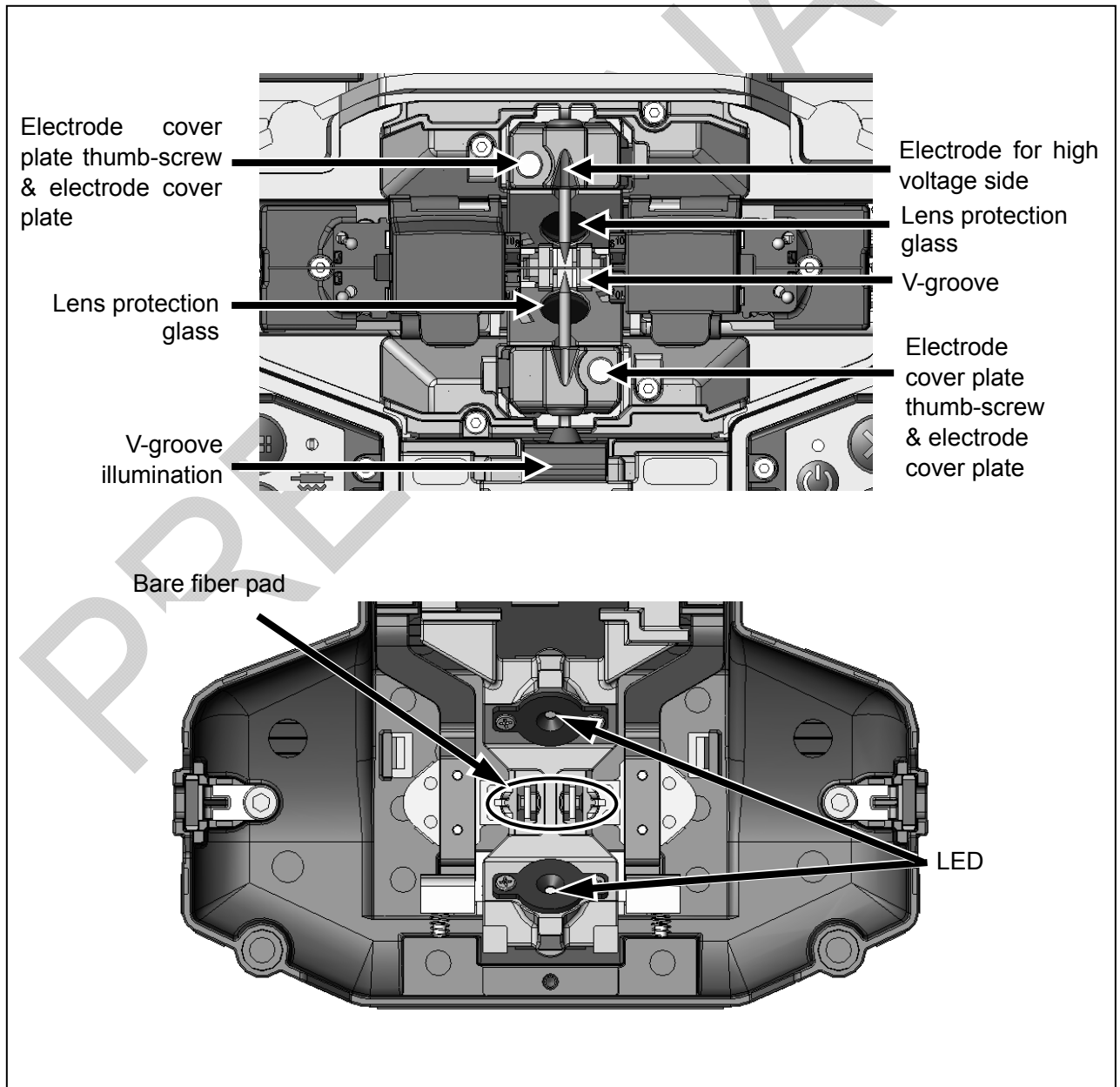

Cleaning V-grooves

Even tiny bits of dust or dirt in the V-grooves might cause the fiber to be offset. To avoid offset, carefully clean the V-grooves with a cotton swab moistened with alcohol.

- 1: Prepare a cotton swab moistened with alcohol.
- 2: Brush the surface of the V-grooves in the direction of the arrow.

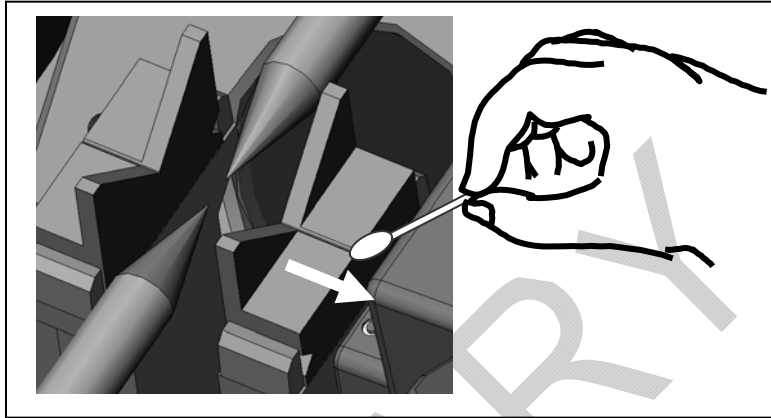

Cleaning LEDs

When a LED surface is dirty, a fiber image is unclear, resulting in imperfect image processing. If the display is uneven or LED error occurs, clean them with a cotton swab moistened with alcohol.

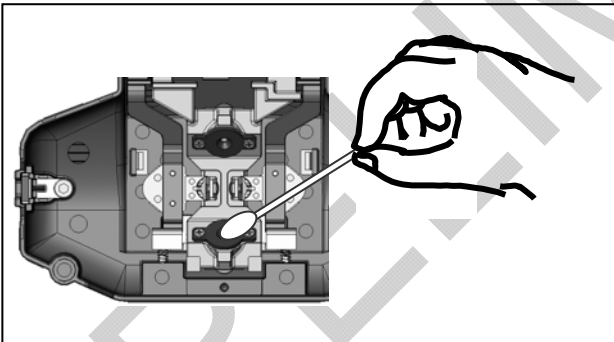

- 1: Prepare a cotton swab moistened with alcohol and wipe the surface of LED lightly.
- 2: Use a dry cotton swab to wipe off any excess alcohol.

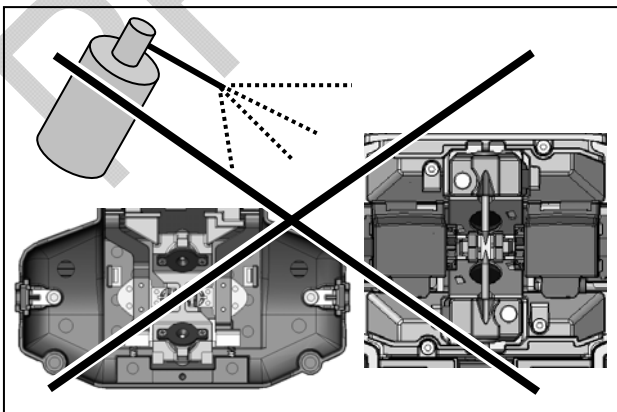

Prohibition

Do not use a canned air for cleaning. Chemical reaction may deteriorate the LED, resulting in a loss of splicing capability.

Cleaning bare fiber pads

Dirt on a bare fiber pad will also cause the fiber to be offset. When fiber offset occurs, clean the bare fiber pad.

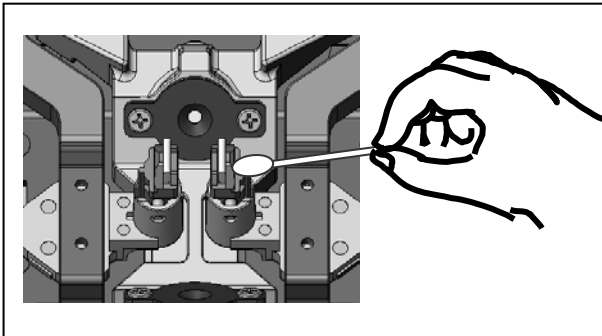

Do not apply too much force when cleaning.

- 1: Prepare a cotton swab moistened with alcohol and wipe the surface of bare fiber pads.
- 2: Use a dry cotton swab to wipe off any excess alcohol.

Cleaning lens protection glass

If an unclear fiber image is still displayed or LED error occurs again after cleaning LEDs, clean the lens protection glass.

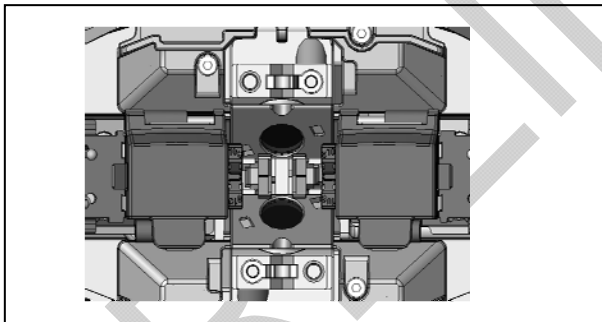

- 1: Remove the electrodes, referring to the "Replacing electrodes".

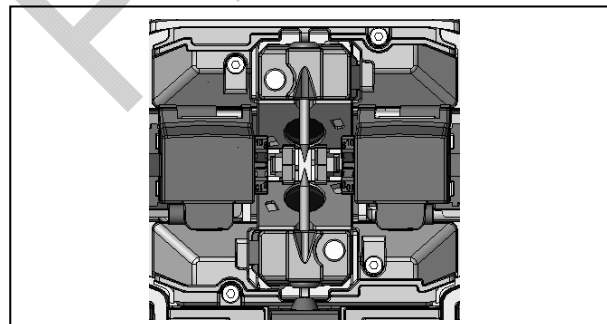
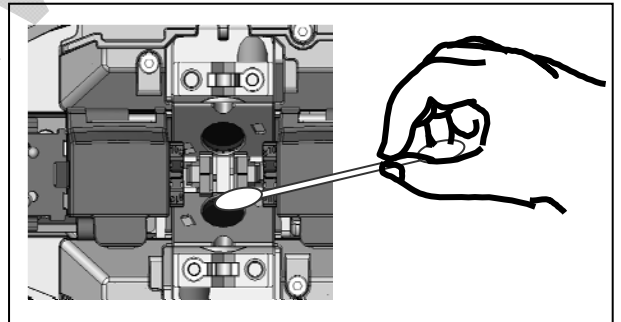

- 2: Prepare a cotton swab moistened with alcohol.
- 3: Gently wipe the lens protection glass in a circular motion.
- 4: Use a dry cotton swab to wipe off any excess alcohol.
- 5: Re-fit the electrodes.
- 6: Perform an arc test.

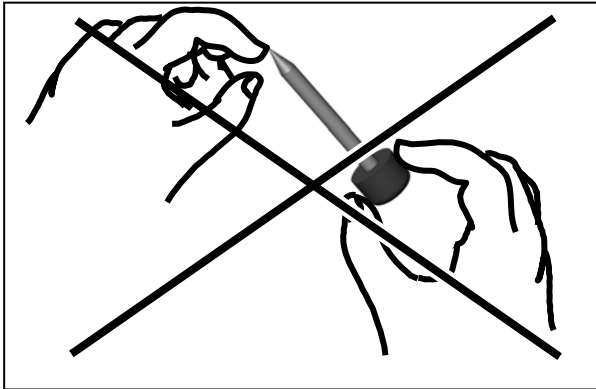

An electrode tip is extremely sharp.
Handle with care.

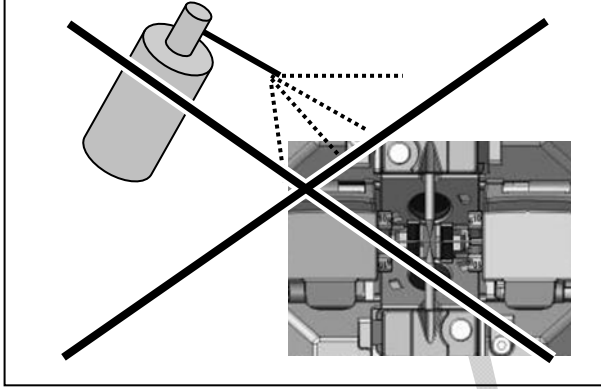

Prohibition

Do not use a canned air for cleaning.
Chemical reaction may deteriorate the
lens protection glass, resulting in a loss
of splicing

Cleaning heat shrink oven

Dirt and dust can accumulate in the heat shrink oven easily. Clean the heating plate regularly with a dry cotton swab.

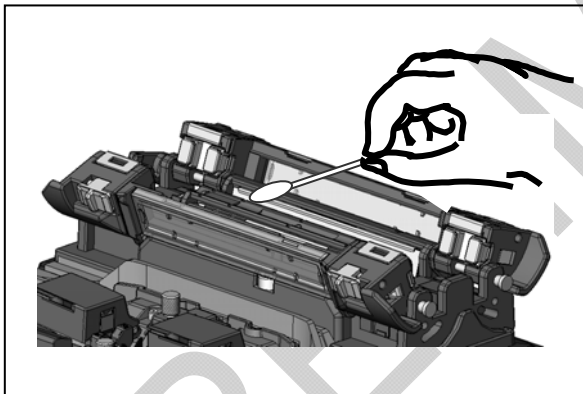

Clean the heating plate with a dry cotton swab.

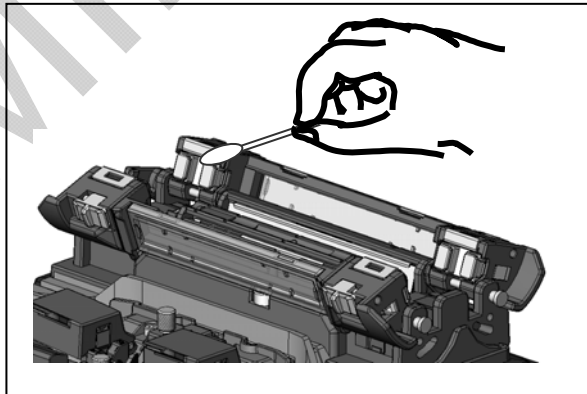

Clean the clamps of the heat shrink oven with
a cotton swab moistened with alcohol.



Caution

Remove moisture or alcohol on the heat shrink oven with a dry
cotton swab.

Replacing electrodes

Electrodes are worn out or contaminated due to silica glass evaporated during arc, and the electrode condition changes day by day. To achieve a repetitive and stable arc for excellent quality splicing, electrodes should be replaced periodically. Continuing to use the same electrodes may result in high splice losses and poor splice strength.

On the TYPE-Q101-CA+, electrodes typically need replacing after approximately 3,000 arc discharges.

If the number of arc discharge exceeds 2,500, Arc Count on the screen will be highlighted in yellow for warning, with a message "Electrodes need changing soon".

If the number exceeds 3,000 times, a warning message appears every time the splicer is powered on and until you replace electrodes according to the replacement procedures described in the next page.

PRELIMINARY

Electrode replacement procedures

Please exchange the electrode to maintain the performance of TYPE-Q101-CA+ at about 3000 discharges. The point of the electrode is very sharp shape. Please take care enough when handling it.

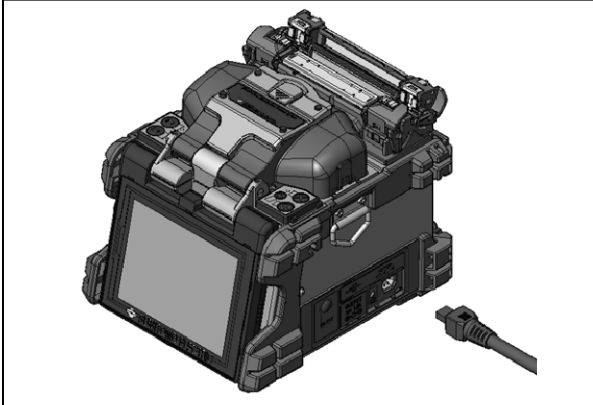

1: Turn off the splicer and unplug the power cord.

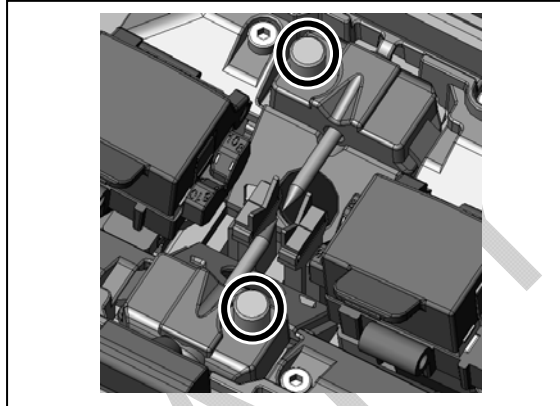

2: Using your fingers, loosen the thumbscrews.

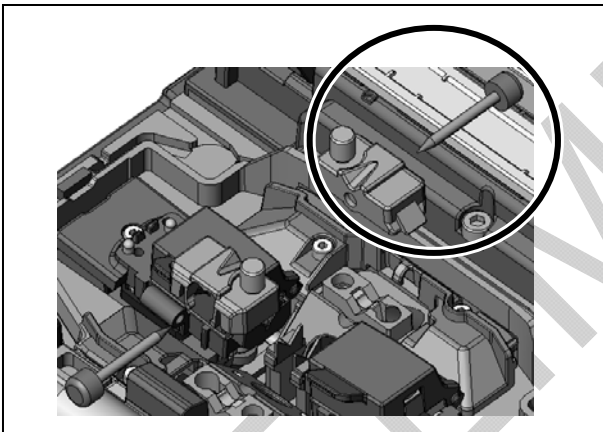

3: Lift the electrode cover plate as shown in the left figure.

4: Remove the old electrode.

5: Install a new electrode.

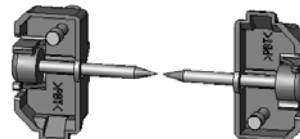

[Back view of electrode and cover plate]



Caution

When handling the electrodes, avoid touching the electrode tips with anything.

6: Tighten the thumbscrew while pressing the electrode below at each electrode cover plate.

7: Repeat step 2 to 5 for the other electrode. Always replace both electrodes at a time.

8: Plug the power cord into the power module and turn on the power to condition the electrodes. (Refer to page 4-14.) After conditioning the electrodes, the Arc count is automatically reset.

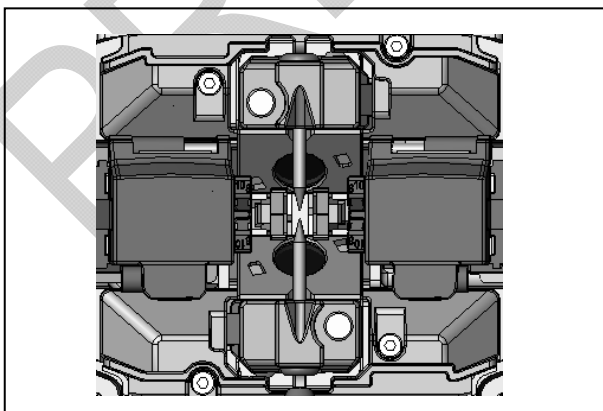

Always replace with Sumitomo genuine electrodes in pairs at a time. Failure to do so can keep the splicer from maximizing its ability.

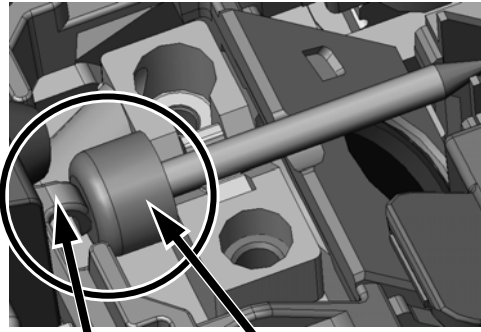

Protrusion Plastic button



Caution

Please confirm the plastic button of the electrode is certainly pushed by the protrusion.

<Correct example>

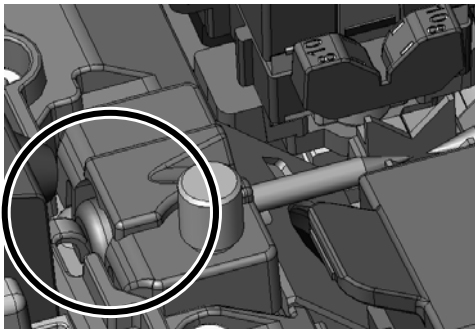

<Wrong example>

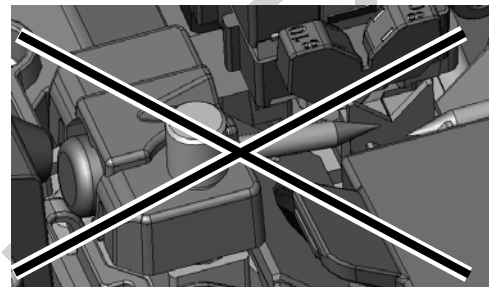

Caution

Splice performance is not steady or the part of splicer is damaged when installing the electrode at a wrong position.

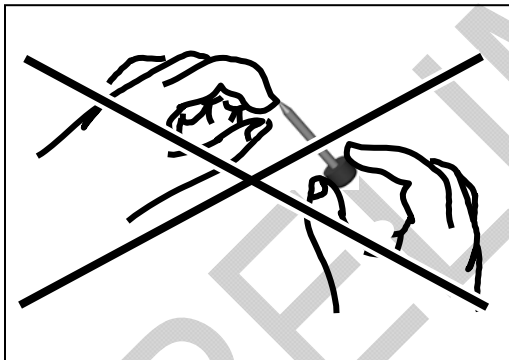

Caution

An electrode tip is extremely sharp. Handle with care.



Caution

- Be sure to turn off the splicer and unplug the power cord or remove the battery pack before replacing the electrodes.
- Discard the old electrodes properly.



Caution

- Do not clean the electrode. Doing so may cause unstable arcing performance.

Packing and storage instructions

- Store the TYPE-Q101-CA+ and its accessories in a designated place in the case referring to the photo below.
- Store the TYPE-Q101-CA+ in the direction shown in the photo below.
- The TYPE-Q101-CA+ with a cooling tray cannot be stored in the case. Remove the cooling tray from the splicer and store it in the pocket.

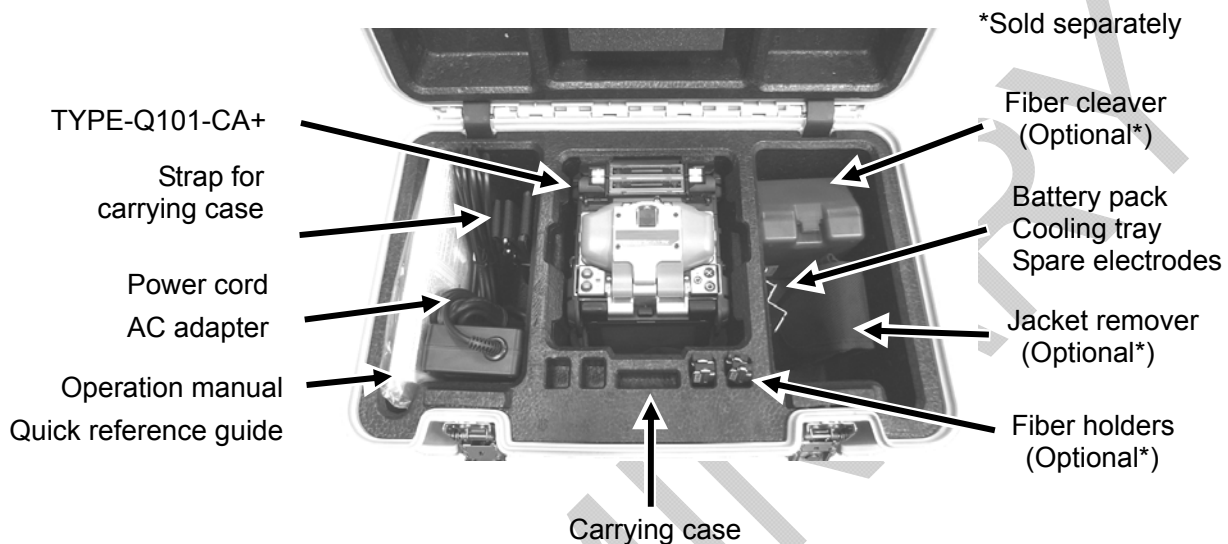

The TYPE-Q101-CA+ fusion splicer is a precision instrument. Its rugged shipping case is custom designed to protect it from impact, dust, dirt, and moisture. Always store and transport the machine in its case. Observe the following instructions.

- Clean the TYPE-Q101-CA+ and all accessories before storing them.
- Be sure to remove the battery pack from the TYPE-Q101-CA+ and store it in a given place.



Warning Keeping the battery in the TYPE-Q101-CA+ may cause the battery terminal to be damaged or deteriorated, resulting in fire.

- Reposition the monitor before storing.
- Discard the liquid solvent properly, or lock the dispenser completely and put it in a plastic bag before packing the dispenser in the case.



Take extreme care of the handling of alcohol.

- Before storing the fiber cleaver, dispose of the fiber fragments collected in the off-cut collector in a proper way.



Glass fiber fragments are extremely sharp. Handle with care.

- Close the carrying case completely and latch it before transportation.
- Pay attention to storage temperature and dew condensation when storing the splicer. The battery is self-discharged during storage. Perform temperature control and charge and discharge the battery once every 6 months.

Storage temperature -20°C ~ +50°C (if stored for less than 1 month)
-20°C ~ +40°C (if stored for less than 3 months)
-20°C ~ +20°C (if stored for less than 1 year)

PRELIMINARY

4. Functions

Splice and heater programs setting

<Splice program setting>

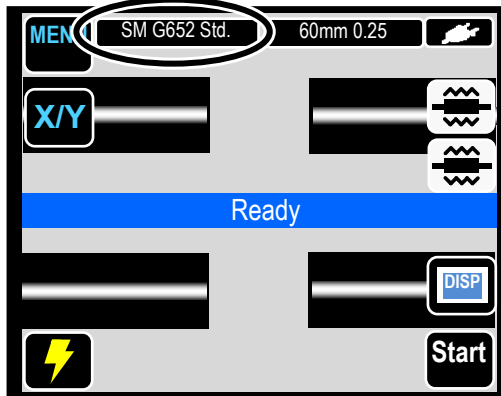

Touch splice program icon once. The icon will expand. Then touch it again.

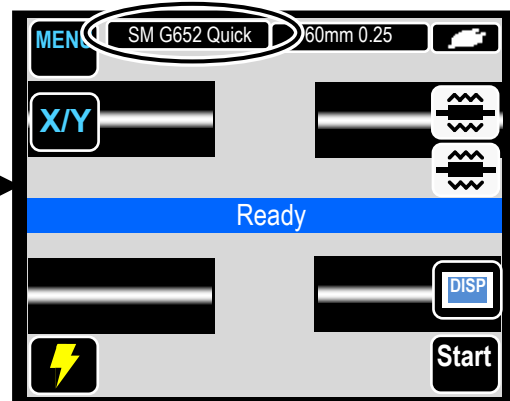

Splice program is changed.

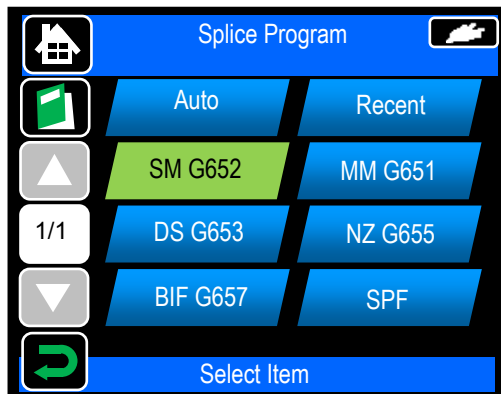

Select the category of fiber type.

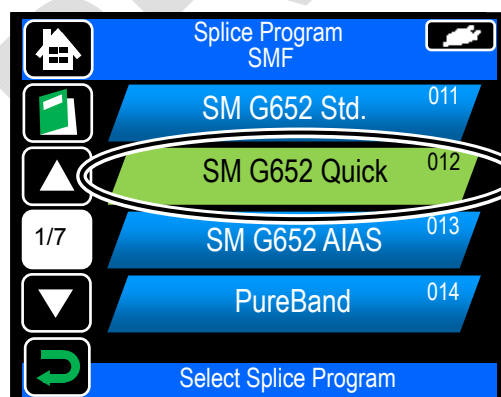

Touch splice program once. The icon will change its color. Then touch it again to determine selection.

For the details of splice programs, refer to page 4-3.

If you would like to change splicer program parameters, refer to page 4-7.

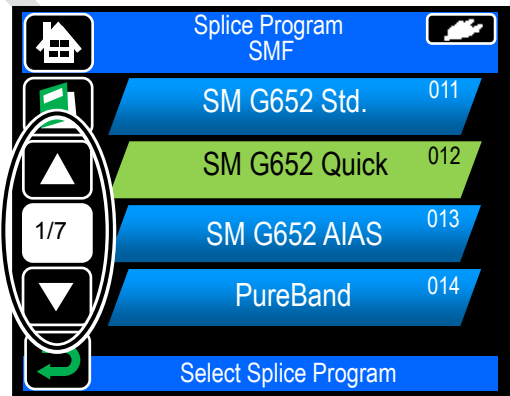

If the page icon ($\frac{x}{x}$) displays the number except "1/1", that means there are other pages. Touch the "move" (\blacktriangle , \blacktriangledown) to go next page or touch the page icon to order the page directly.

<Heater program setting>

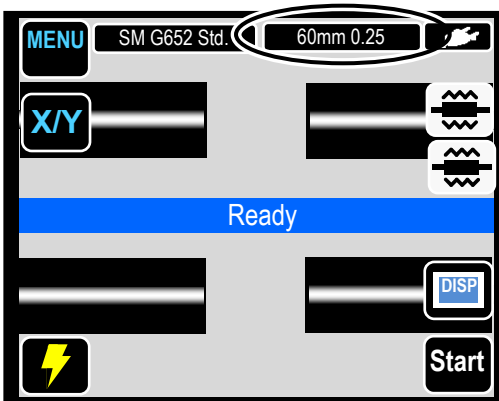

Touch heater program icon once. The icon will expand. Then touch it again.

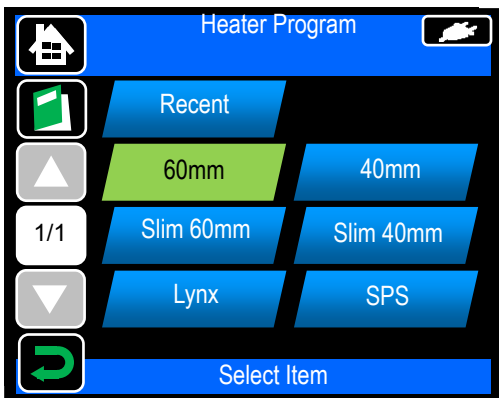

Select the category of fiber protection sleeve.

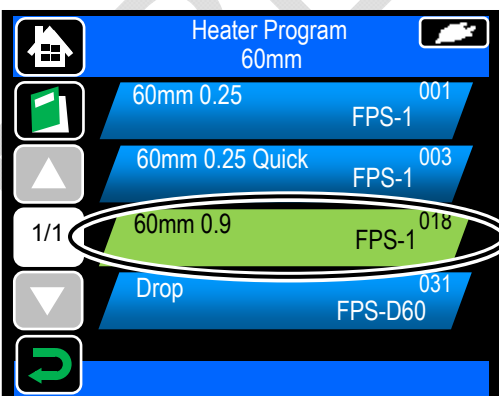

Touch heater program once. The icon will change its color. Then touch it again to determine selection.

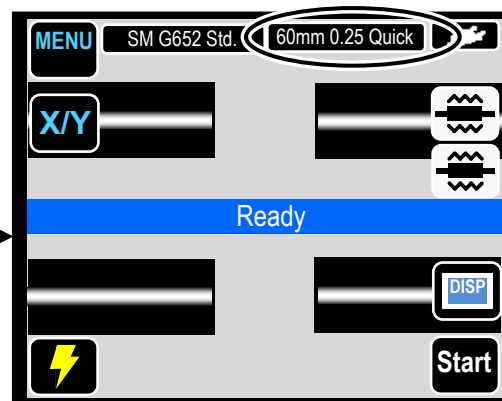

Heater program is changed.

For the details of heater programs, refer to page 4-5.
If you would like to change heater program parameters, refer to page 4-7.

Splice programs

Category	Splice Program	Details
Auto	Auto	<p>Using Auto fiber Profiling check and Detection System (APDS*1), the TYPE-Q101-CA+ recognizes the type of fiber loaded, automatically chooses the correct splice program, and proceeds to splicing. This mode enables to splice standard SMF (ITU-T G.652), MMF (ITU-T G.651), DSF (ITU-T G.653), NZDSF (ITU-T G.655) and BIF (Bend Insensitive fiber, ITU-T G.657). The recognized fiber type is displayed below a fiber image on the monitor screen.</p> <p>ATTENTION</p> <ul style="list-style-type: none"> • The recognizable fiber types are Standard SMF, MMF, DSF, NZDSF and BIF. • DSF is recognized as NZDSF. • The fiber detection is conducted on left and right fibers individually. • The data on representative core profiles of standard fiber types are stored in the TYPE-Q101-CA+. However, other manufacturers' and new design fibers may sometimes be recognized incorrectly. In this case, please select suitable splice program by yourself. • Even if fibers are sorted in the same category, suitable splice program is sometimes different depending on the manufacturers or fibers. In this case, please select the suitable splice program by yourself.
	SM G652 Auto	Can be used for splicing identical SMF (ITU-T G.652). Please select the problem when knowing the fiber profile to be spliced.
	MM G651 Auto	Can be used for splicing identical MMF (ITU-T G.651). Please select the problem when knowing the fiber profile to be spliced.
	DS G653 Auto	Can be used for splicing identical DSF (ITU-T G.653). Please select the problem when knowing the fiber profile to be spliced.
	NZ G655 Auto	Can be used for splicing identical NZDSF (ITU-T G.655). Please select the problem when knowing the fiber profile to be spliced.
	BIF G657 Auto	Can be used for splicing identical BIF (ITU-T G.657). Please select the problem when knowing the fiber profile to be spliced.

*1: The splicer automatically recognizes optical fiber type loaded via image processing, verifies the selected splice condition matches the fiber, and also displays the results if a mismatch is detected. This system prevents an operator from splicing with the incorrect program.

About Auto Arc Power

In the Auto mode, TYPE-Q101-CA+ analyzes the arc and has the function to calibrate the arc condition automatically at each splice. Therefore, arc test is not needed usually in the Auto mode.

Perform an arc test in the following situations to calibrate the arc power and position.

- Poor splice performance (high or inconsistent splice losses, poor splice strength)
- After electrode replacement
- Extreme changes in temperatures, humidity or air pressure

Please perform an arc test before splicing on all splice programs except Auto mode.

Category	Splice Program	Details
SM G652	SM G652 Std.	Can be used for splicing identical standard SMF (ITU-T G.652).
	SM G652 Quick	Can be used for splicing identical standard SMF (ITU-T G.652) and making a faster splice. In this mode APDS is disabled.
	SM G652 AIAS	Automatic Intentional Axis Shift function (AIAS*2) enables to splice identical standard SMF (ITU-T G.652) with high core-cladding eccentricities.
	Other SMF	The splice programs that include standard SMF are listed. ex)SMF-DSF
	SM ATTN1	This mode can be used for splicing fibers by shifting the centers of the left and right fiber cores and achieving intentional high splice losses. Recommended target attenuation range: 0.1~5.0dB An estimated splice loss displayed in the splicer may not match an actual splice loss depending on the fiber type being spliced. It is recommended that actual splice losses be measured and checked with a power meter. <ul style="list-style-type: none"> • Target Loss: Enter a target splice loss in "Setting" settings (2/6 page). User settable attenuation range is 0.1~15dB (in increments of 0.1dB). • ATTN Coef.: If the target splice loss does not match an actual loss, modify this value in "Function" settings.
MM G651	MM G651 Std.	Can be used for splicing identical standard MMF (ITU-T G.651).
	MM G651 Quick	Can be used for splicing identical standard MMF (ITU-T G.651) and making a faster splice. In this mode APDS is disabled.
	Other MMF	Can be used for splicing other representative MMF (ITU-T G.651).
DS G653	DS G653 Std.	Can be used for splicing identical standard DSF (ITU-T G.653).
	DS G653 Quick	Can be used for splicing identical standard DSF (ITU-T G.653) and making a faster splice. In this mode APDS is disabled.
NZ G655	NZ G655 Typ.	Can be used for splicing identical standard NZDS (ITU-T G.655).
	NZ G655 Quick	Can be used for splicing identical standard NZDSF (ITU-T G.655) and making a faster splice. In this mode APDS is disabled.
	Other NZDSF	Can be used for splicing other representative NZDSF (ITU-T G.655).
BIF G657	G657 adaptive	Can be used for splicing BIF (Bend Insensitive fiber, ITU-T G.657). This mode helps to splice optical fiber with complicated core profile.
	G657 Quick	Can be used for splicing identical standard BIF (ITU-T G.657) and making a faster splice. In this mode APDS is disabled.
	Other BIF	The splice programs of each manufacturer's BIF are listed.
SPF	—	The splice programs of special fibers, such as EDF and photonic fiber, which do not belong to other categories are listed.
Recent	—	The splice program selected recently is listed.

*2: High core-cladding eccentricities have an effect on surface tension during arc, yielding high splice loss. This method is used to intentionally offset the left and right fiber centers in order to minimize this effect.

Heater programs

The heating programs are optimized for Sumitomo protection sleeves. Select an appropriate heater program for the protection sleeve you are using.

category	Heater program	Details
Recent	—	The splice program selected recently is listed.
60mm	60mm 0.25	Can be used for heat shrinking 60mm protection sleeves for single fiber with 0.25mm coating, for example, Sumitomo FPS-1.
	60mm 0.25 Quick	Can be used for heat shrinking 60mm protection sleeves for single fiber with 0.25mm coating, for example, Sumitomo FPS-1. Select the program if you would like to reduce the heating cycle time. On the program, the heater is automatically heated up to the pre-heating temperature when the fusion splicing process is finished.
	60mm 0.9	Can be used for heat shrinking 60mm protection sleeves for single fiber with 0.9mm coating, for example, Sumitomo FPS-1.
	Drop	Can be used for heat shrinking 60mm protection sleeves for drop cable splice, for example, Sumitomo FPS-D60.
40mm	40mm 0.25	Can be used for heat shrinking 40mm protection sleeves for single fiber with 0.25mm coating, for example, Sumitomo FPS-40.
	40mm 0.25 Quick	Can be used for heat shrinking 40mm protection sleeves for single fiber with 0.25mm coating, for example, Sumitomo FPS-40. Select the program if you would like to reduce the heating cycle time. On the program, the heater is automatically heated up to the pre-heating temperature when the fusion splicing process is finished.
	40mm 0.9	Can be used for heat shrinking 40mm protection sleeves for single fiber with 0.9mm coating, for example, Sumitomo FPS-40.
	40mm 0.4	Can be used for heat shrinking 40mm protection sleeves of Nano Sleeves N4 series, for example, Sumitomo FPS-N4-40.
Slim 60mm	S60mm 0.25	Can be used for heat shrinking 60mm semi-shrunk protection sleeves for single fiber, for example, FPS-61-2.6.
	S60mm 0.25 Quick	Can be used for heat shrinking 60mm semi-shrunk protection sleeves for single fiber, for example, FPS-61-2.6. Select the program if you would like to reduce the heating cycle time. On the program, the heater is automatically heated up to the pre-heating temperature when the fusion splicing process is finished.
	S60mm0.25+5s	The program which heating duration is 5 sec. longer than "S60mm 0.25".
	S60mm0.25-5s	The program which heating duration is 5 sec. shorter than "S60mm 0.25".
Slim 40mm	S40mm 0.25	Can be used for heat shrinking 40mm semi-shrunk protection sleeves for single fiber, for example, FPS-40-2.6.
	S40mm 0.25 Quick	Can be used for heat shrinking 40mm semi-shrunk protection sleeves for single fiber, for example, FPS-40-2.6. Select the program if you would like to reduce the heating cycle time. On the program, the heater is automatically heated up to the pre-heating temperature when the fusion splicing process is finished.
	S40mm0.25+5s	The program which heating duration is 5 sec. longer than "S40mm 0.25".
	S40mm0.25-5s	The program which heating duration is 5 sec. shorter than "S40mm 0.25".
Lynx	LYNX	Can be used for heat shrinking protection sleeves for 10mm cleaved Sumitomo's splice-on-connector "Lynx-CustomFit".
	LYNX MINI	Can be used for heat shrinking protection sleeves for 5mm cleaved Sumitomo's splice-on-connector "Lynx-CustomFit".

category	Heater program	Details
SPS	25mm 0.4	Can be used for heat shrinking 25mm protection sleeves of Nano Sleeves N4 series, for example, Sumitomo FPS-N4-25.
	20mm 0.4	Can be used for heat shrinking 20mm protection sleeves of Nano Sleeves N4 series, for example, Sumitomo FPS-N4-20.
	25mm 0.9	Can be used for heat shrinking 25mm protection sleeves of Nano Sleeves N9 series, for example, Sumitomo FPS-N9-25.
	20mm 0.9	Can be used for heat shrinking 20mm protection sleeves of Nano Sleeves N9 series, for example, Sumitomo FPS-N9-20.

PRELIMINARY

<Change splice program parameter>

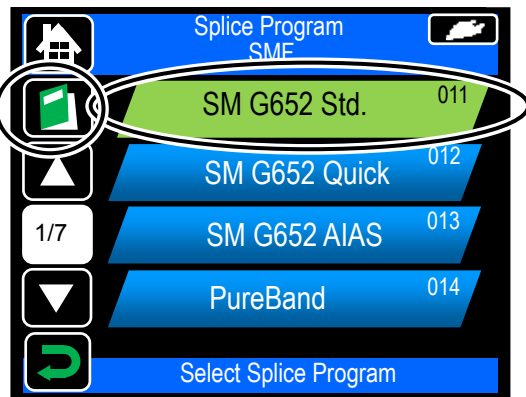

In the splice program setting screen (page 4-1), select the program (change the color), then touch "Setting" icon (). Item select screen is displayed.

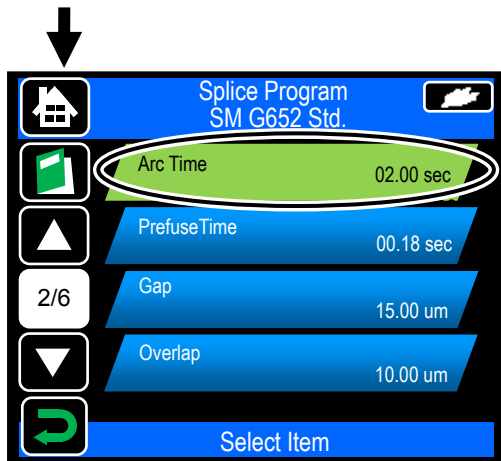

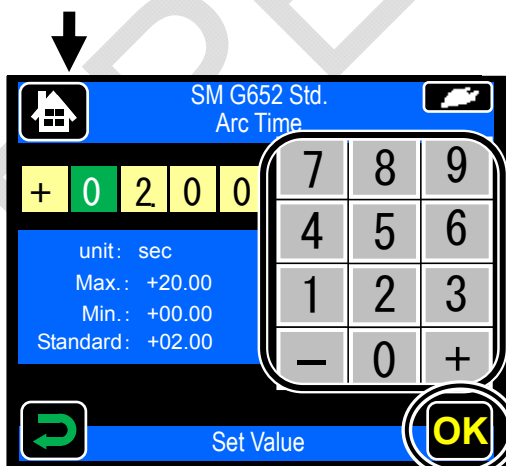

Touch the item once. The icon will change its color. Then touch it again to determine selection.

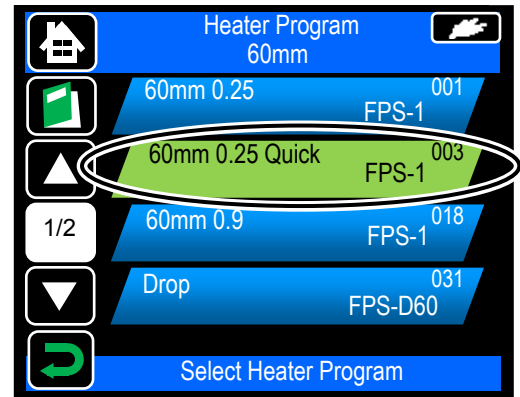

Input the value by touching number keys, then touch "OK" ().

<Change heater program parameter>



In the heater program setting screen (page 4-2), select the program (change the color), then touch "Setting" icon (). Item select screen is displayed.

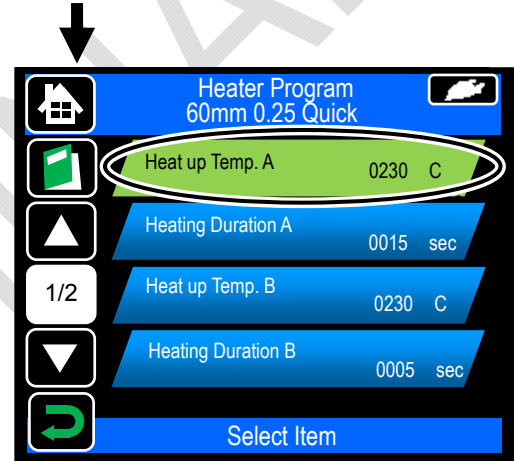

Touch the item once. The icon will change its color. Then touch it again to determine selection.

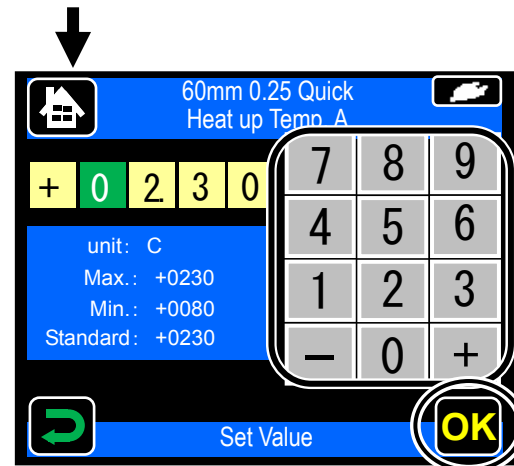

Input the value by touching number keys, then touch "OK" ().

<Splice program settings>

Page	Item	Details
1/6	Name	Allows to edit splice program name.
	Template	Allows to choose splice program as a template when new splice program is created.
	Align Method	Sets the alignment method for fibers to be spliced. Choose from "Core", "Adaptive", "Diameter" and "AIAS". "Core"...Aligns center of right and left optical fiber cores. "Adaptive"...is effective when optical fiber with complex core profile is spliced. "Diameter"...Aligns center of right and left optical fiber diameters. "AIAS"...When core to cladding concentricity is high, surface tension pulls the claddings into alignment and misaligns the cores, causing high splice loss. The splicer automatically performs axis shift prior to arc fusion when it foresees the problem.
	Auto Power	Automatically optimizes arc power.
2/6	Arc Time	Sets the arc fusion time.
	Prefuse Time	Sets the time between start of arc fusion and feeding of fibers.
	Gap	Sets the gap between fiber end faces before arc fusion.
	Overlap	Sets the distance of feeding fiber.
3/6	Arc Power	Sets the arc power. Generally it is automatically set by an arc test and does not need to be changed. It is shown as [Standard + XX]. [Standard] means pre-set arc power. [+ XX] can be manually increased or decreased.
	Gapset Position	Sets the position of splicing fibers. Generally it is automatically set by an arc test and does not need to be changed.
	Cleaning Arc Time	Sets the cleaning arc time for removing dust from optical fiber.
	Rearc Time	Sets the additional arc time to be conducted after splicing.
4/6	Splice Method	Set the splice mode to Auto or Manual.
5/6	Fiber Detection	Automatically identifies fiber profile loaded.
	Cleave Angle Limit	Sets the threshold of cleave angle. If a reading exceeds the threshold, the splicer will give an error.
	Core Angle Limit	Sets the threshold of core angle. If a reading exceeds the threshold, the splicer will give an error.
	Est. Loss Limit	Sets the threshold of estimated loss. If a reading exceeds the threshold, the splicer will give an error.
6/6	Estimation Mode	Sets the loss estimation method to "High" or "Standard". If "High" is chosen, the splicer will observe and inspect the core of spliced fiber with very high precision after fusion splicing.
	MFD-L	Sets the MFD of left side optical fiber.
	MDL-R	Sets the MFD of right side optical fiber.
	Wavelength	Sets the wavelength for loss estimation calculation.

<How an arc discharges and motors run during the splicing process>

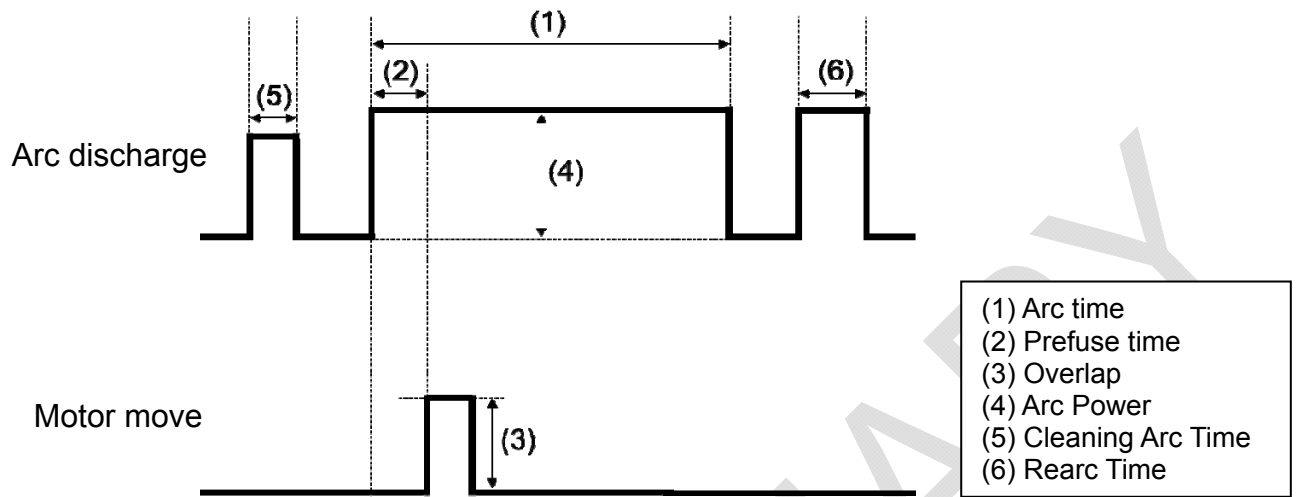

<Heater program settings>

Page	Item	Details
1/2	Heat up Temp A	Heating element rise up to the set temperature in the first term of heating cycle. (Numerical input)
	Heating Duration A	Duration of the first term of heating cycle. (Numerical input)
	Heat up Temp B	Heating element rise up to the set temperature in the middle term of heating cycle. (Numerical input)
	Heating Duration B	Duration of the middle term of heating cycle. (Numerical input)
2/2	Finish Temp	The temperature of finishing heating cycle after cooling by the fan. (Numerical input)
	Preheating temperature*	Temperature for the pre-heating duration of the heating cycle. (Numerical input)
	Preheating time*	Duration for maintaining the Pre-heating Temp. (Numerical input) *When the heating process is started, the pre-heating process is automatically finished.

*For Quick of Heater program

The heating control system

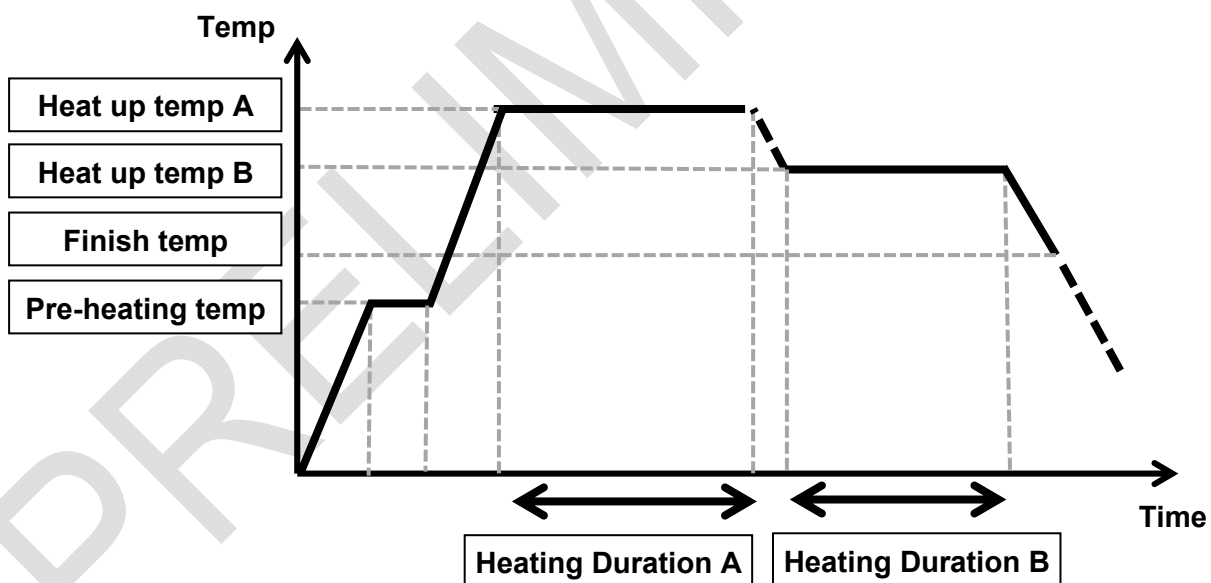

The heating control is applied to each heater.

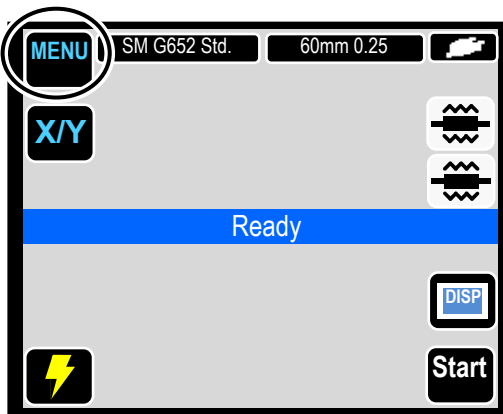

Touch “Menu” () to go to menu screen.

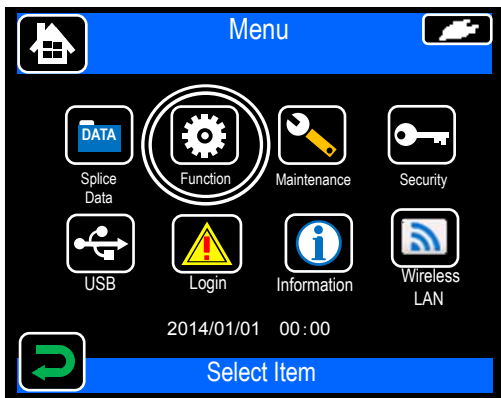



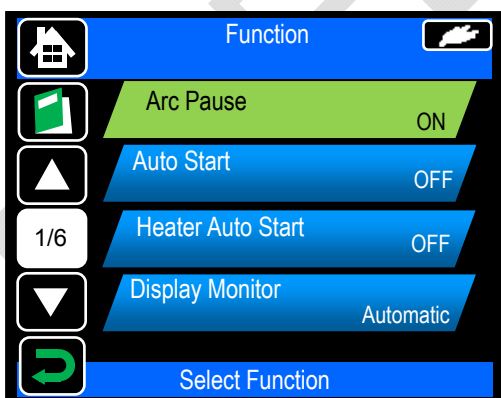

Touch “Function” () to go to function screen.

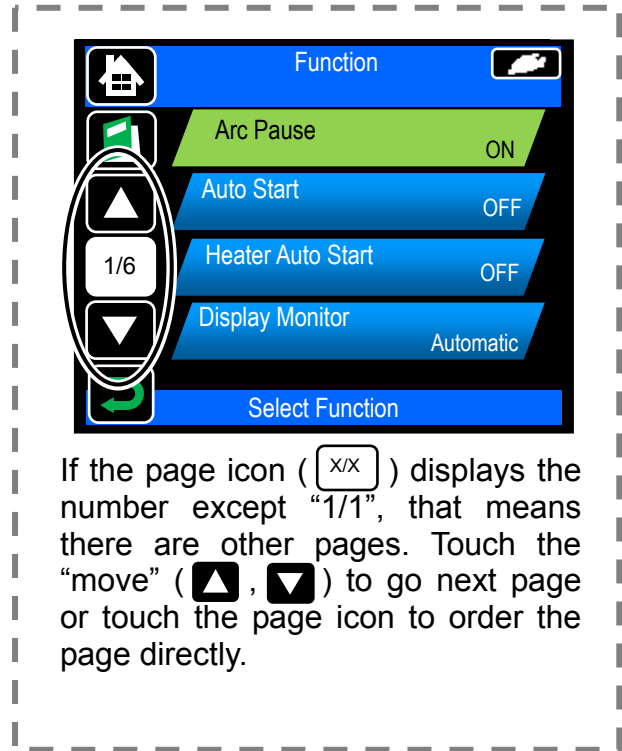

Touch the item once. The icon will change its color. Then touch it again to go to setting screen.

For more details of the items of function, please refer to the page 4-13.



If the page icon () displays the number except “1/1”, that means there are other pages. Touch the “move” ( , ) to go next page or touch the page icon to order the page directly.

Screen indication

In the function setting item of following * sign, the displaying method of the screen can be selected.

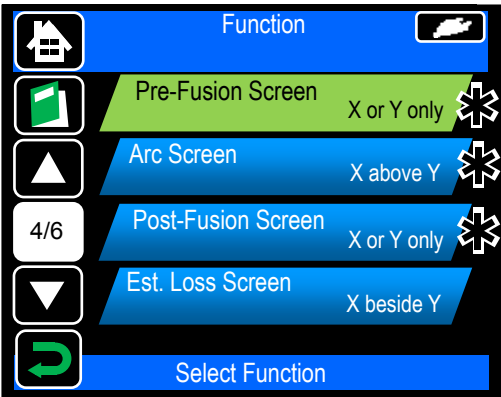
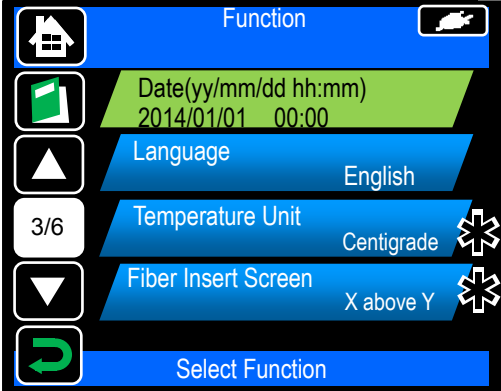

X or Y only

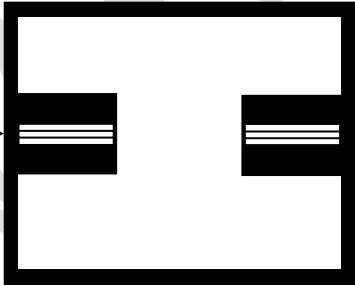

If "X or Y only" is selected, X or Y screen is displayed on the screen.

X above Y

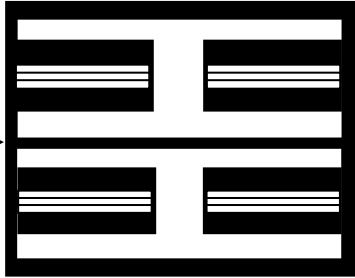

If "X above Y" is selected, X and Y screens are vertically displayed on the screen.

X beside Y

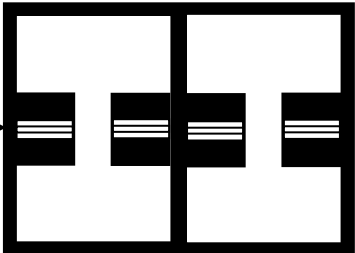

If "X beside Y" is selected, X and Y screens are horizontally displayed on the screen.

Page	Functions	Details
1/6	Arc Pause	This function stops the splicing process before arcing occurs. If you would like to check offset and fiber end faces, set this function to ON.
	Auto Start	This function starts the splicing process when the fiber is inserted in the splicer and the hood is closed.
	Heater Auto Start	This function starts the heating process when the fiber is placed into the heat shrink oven.
	Display Monitor	Front monitor type or Back monitor type can be selected.
2/6	ECO Mode	Saves power consumption by adjusting monitor brightness and heat shrink oven temperature
	Sleep	If the splicer is not interrupted for a certain span of time, to minimize power consumption on standby, the monitor and 12VDC will be turned off. (The Power LED will be lit in orange.) To return to normal operation, press any key, except the Power key.
	Auto Power Off	If the splicer is in Sleep mode and is not interrupted for another certain span of time, the splicer is automatically powered off. You need to switch on the splicer again.
	Bright	The brightness of the monitor can be adjusted by four stages.
3/6	Date	This function sets the built-in clock of the splicer to local time.
	Language	The language being displayed can be selected. (Some languages cannot be selected.)
	Temperature Unit	This function switches the temperature units.
	Fiber Insert Screen	Single (X or Y) screen type or dual (X and Y) screen type can be selected in each step of the splicing process. For further details, please refer to page 4-12.
4/6	Pre-Fusion Screen	
	Arc Screen	
	Post-Fusion Screen	
	Est. Loss Screen	
5/6	Buzzer (Key)	Buzzer sound of touching icons or pressing keys can be selected. "Mute" can be selected too.
	Buzzer (Stop)	Buzzer sound of arc pause can be selected. "Mute" can be selected too.
	Buzzer (Error)	Buzzer sound of detecting errors during splice. "Mute" can be selected too.
	Audio Volume	The volume of the speaker can be adjusted by four stages.
6/6	Light for v-groove	This function sets the V-groove illumination to ON or OFF.

Maintenance settings

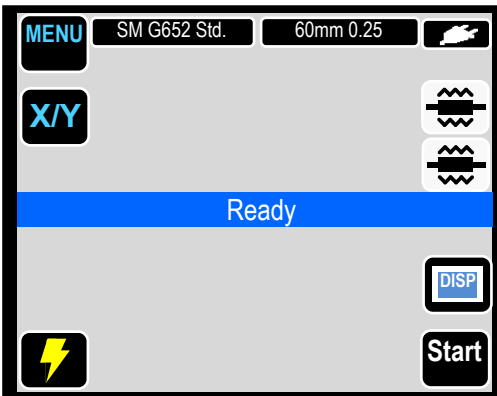

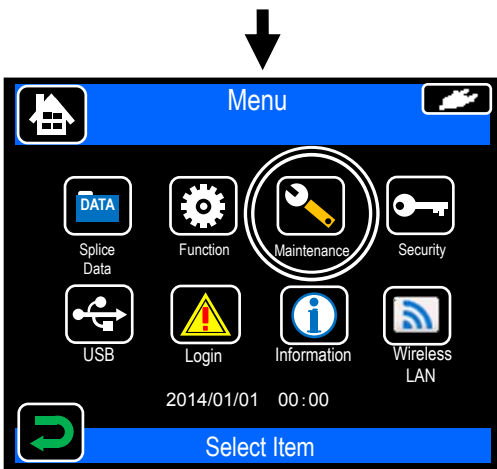

Touch "MENU" () to go to Menu screen.

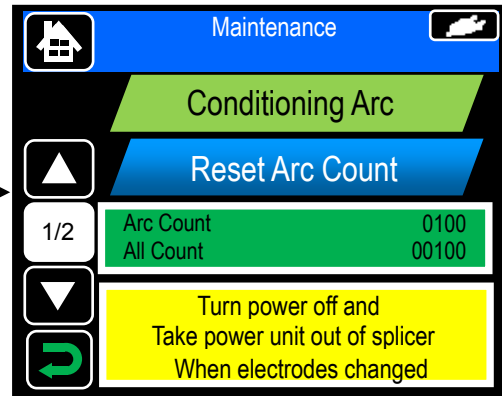

In the menu screen, touch "Maintenance" icon () to go to Maintenance screen.



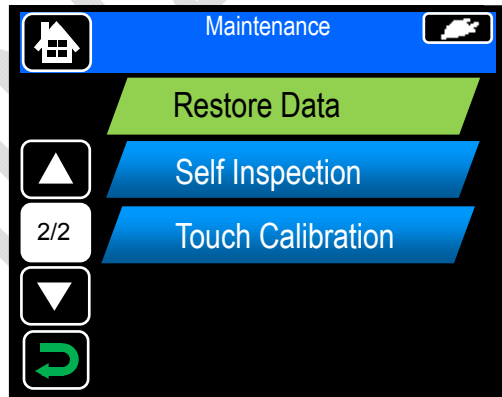

Touch the item once. The icon will change its color. Then touch it again to determine selection. Touch the "move" ( , ) to go next page.

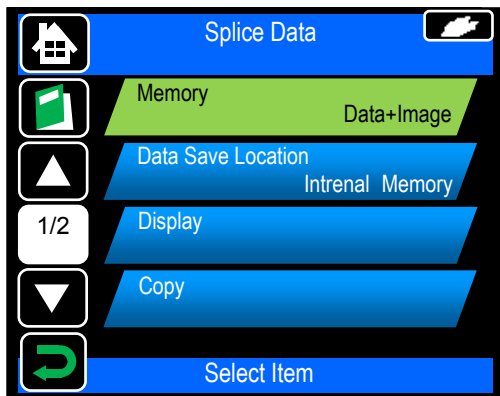

Page	Item	Details
1/2	Conditioning Arc	After the electrodes are replaced, this function is used to condition a new electrode. The number of conditioning arc is preset. Arc Count is automatically reset after conditioning arc is performed.
	Reset Arc Count	Arc Count can be reset, while All Count cannot.
2/2	Restore Data	All parameters except Arc Count and All Count are returned to the factory setting.
	Self Inspection	The circuit board, optical unit, motors and heat shrink ovens are automatically inspected.
	Touch Calibration	Perform touch calibration when icons and items could not be selected correctly with touching operation.

Splice data storage function



Touch the “Splice Data” icon () on the menu screen to go to DATA screen. Please set "Memory" item ON before splicing if you want to save the splice data.

To display stored splice data, select “Display”. Enter the memory location you would like to view.

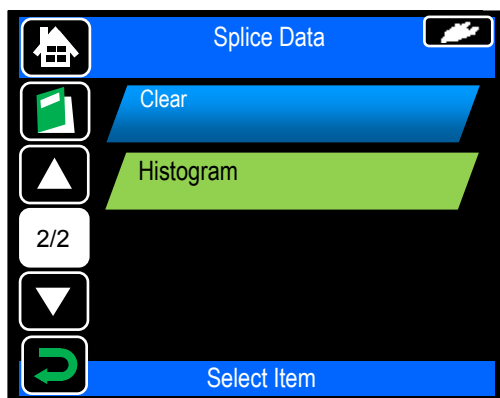



When "Copy" item is selected, the saved data is copied onto the SD card in CSV format.

In "Histogram" item, the histogram of estimated loss and angle can be displayed based on the data that has been recorded.

Description of data

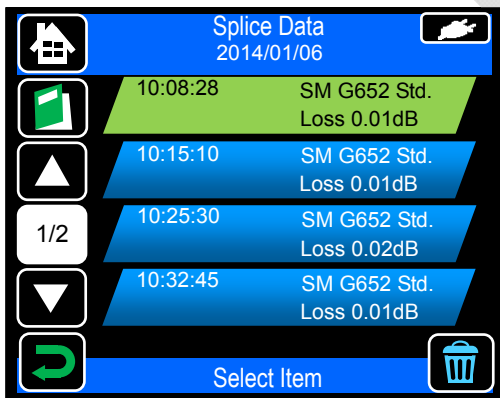
- ◆ Cleave Angle : Inspected cleave angle of the (L/R) fiber.
- ◆ Fiber Offset : Inspected offset of the core axis (or diameter axis).
- ◆ Core Offset : Inspected core step status of the offset caused by deformation.
- ◆ Core Angle : Inspected tilt angle of the core axis caused by deformation.
- ◆ Concentricity : Inspected core eccentricity of the (L/R) fiber.



When the dust box icon () is touched, the referred data is deleted.

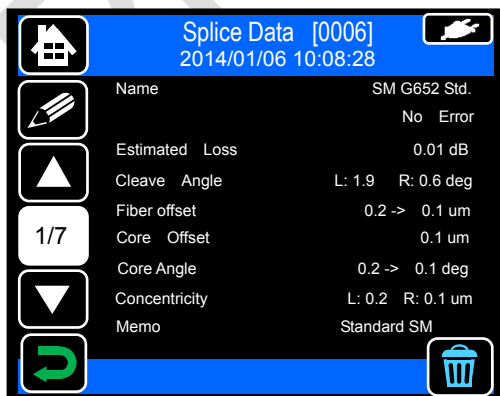

Add the memo by touching “MEMO” ().

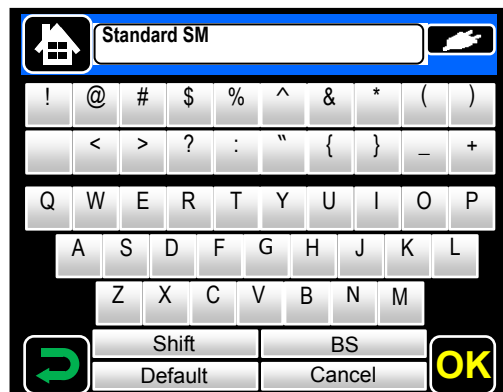

USB connection function

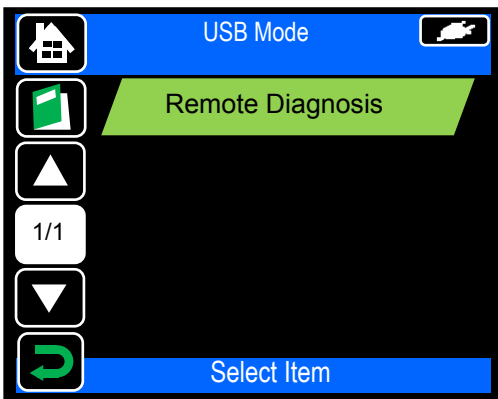

Touch USB icon () in the menu screen to go to the USB mode screen. The following functions can be used by connecting TYPE-Q101-CA+ with the PC via USB cable, and selecting each item.

<Remote Diagnosis>

Select this item when TYPE-Q101-CA+ is connected with the PC for the Internet maintenance.

Software download via internet

By accessing to the URL below and getting a maintenance application, customers can upgrade newest software via internet. For further information, please access to the URL and refer to the manual.

<http://www.rim-plus.sei.co.jp/>

Login function

By inputting the pass code, the expanded functions for the administrator can be used. Please refer to "Administrator menu operation instructions" for details.



Help function

TYPE-Q101-CA+ has a function to display the user training video such as the method of the preprocessing of the fiber, the daily checkup, and the cleaning in animation. It is possible to run the video, to stop temporarily, and to confirm the work procedure details.

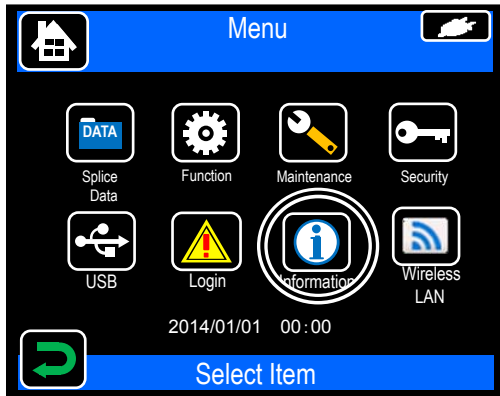

Touch the "Information" icon () in menu screen to go to movie screen.

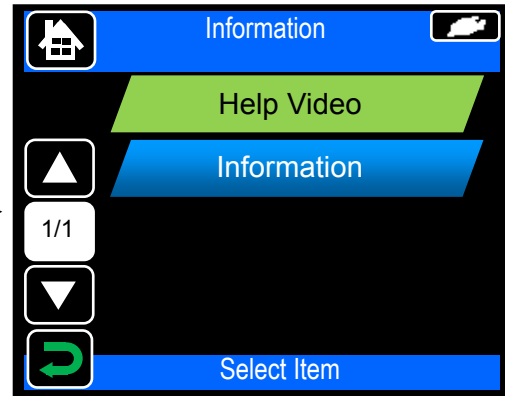

Select "Help Video" item.

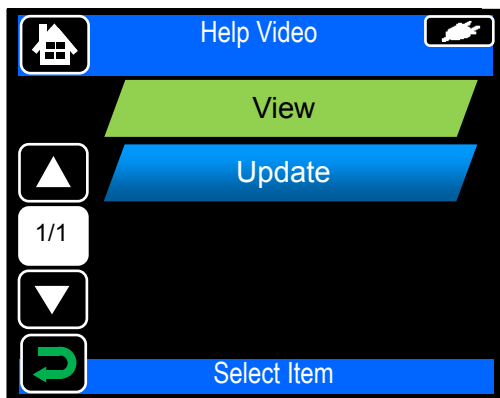

Select "View" item.

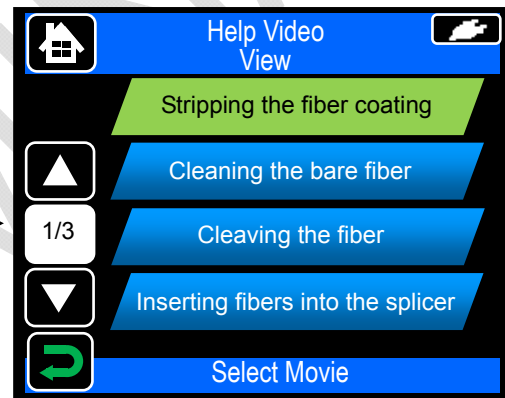

Select the movie.

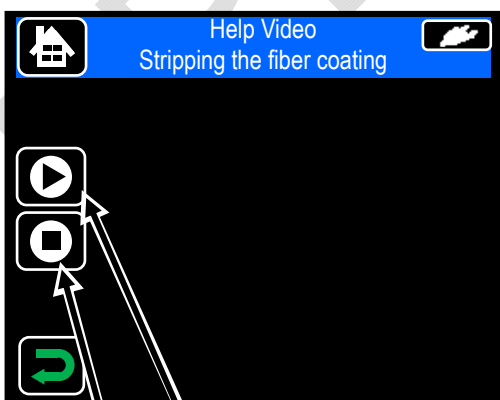

Start / Pause
Stop

Wireless LAN feature

The TYPE-Q101-CA+ can connect to a smartphone via Wi-Fi using a dedicated wireless LAN SD card (WLSD-0208) and can be operated with the smartphone.

For the connection, smartphone application “SumiFi” is required. Install it from “Google Play” online store.



1. Insert the wireless LAN SD card into the splicer.
2. Tap the Wireless LAN icon () to enable wireless LAN connection.
3. Set “Connection to smartphone” to “ON” to enable wireless LAN connection to connect the splicer to a smartphone via Wi-Fi. When wireless LAN connection becomes available, wireless LAN icon appears on the monitor screen.

4. Start “SumiFi” on the smartphone.

*If the wireless LAN SD card is not inserted in the splicer, the function cannot be enabled.

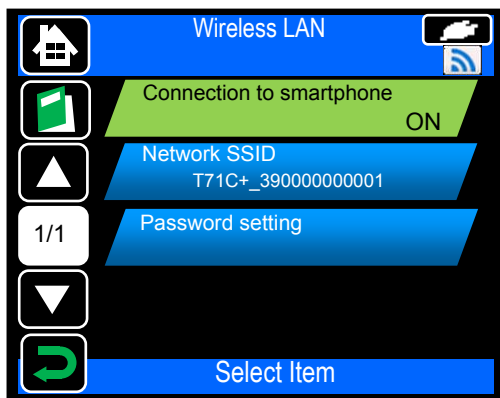

[Wireless LAN menu options]

- Network SSID: is the name that devices can identify an inserted SD card as.
- Password setting: is required to connect the splicer to devices. Choose this option to change a password. The password must be 8-20 alphanumeric characters long.

To validate a new password, re-boot the splicer.

*Factory default password is “12345678”.

SumiFi smartphone application features

*For further information such as operating procedures, refer to Help option in “SumiFi” menu.

Function	Details
Download splice data	Downloads stored splice text and image data on the smartphone. Automatic data downloading is also possible.
Log GPS data	Using smartphone’s GPS function, adds GPS location data in compressed format to stored splice text and image data.
Send email	Sends splice text and image data with GPS location data via email on the smartphone.
Splicers settings	Edits splice and heater program settings on the smartphone.
Remote control	Captures splicer’s monitor screens from the smartphone.

PRELIMINARY

5. Other convenient functions

The TYPE-Q101-CA+ is provided with various functions. Set up the functions as necessary.

Back monitor type

The back monitor type is convenient when you would like to place the fiber to be spliced for installation closer to you.

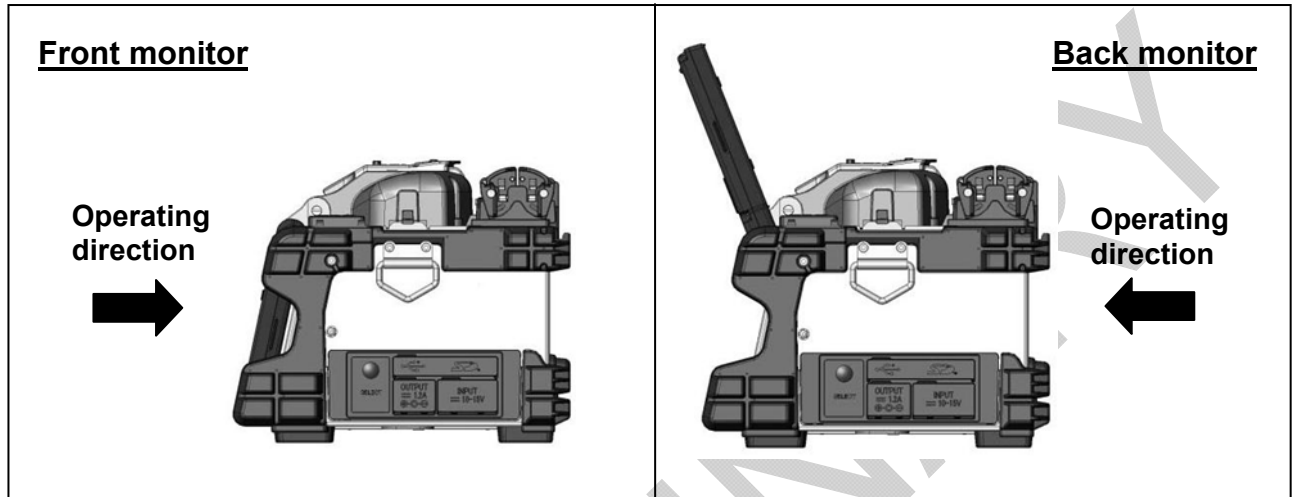

The monitor display reverses automatically when the monitor is moved to the position of the back monitor type. (Refer to the page 4-13)

When using the splicer by the back monitor type, it is easy to work if the right and left of the coating clamp is replaced according to the following procedures.

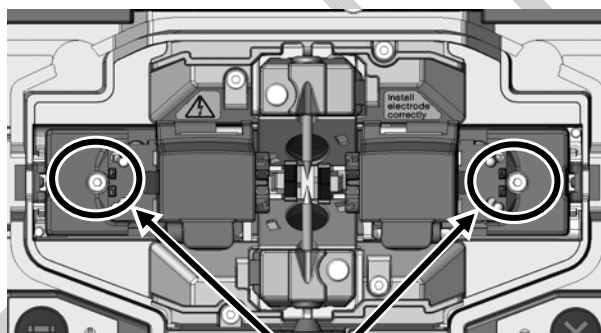

Coating clamp fixation screw

1. Loosen the right and left coating clamp fixation screw, and detach the coating clamp.

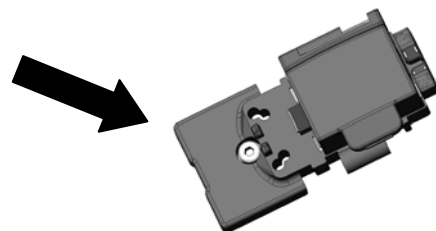

Coating clamp

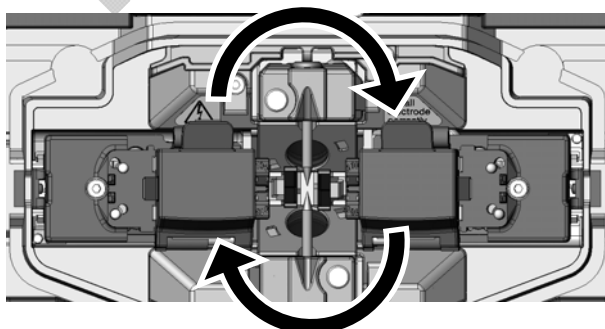

2. After replacing right and left coating clamp, tighten the coating clamp fixation screw. The lid of the coating clamp opens in the same direction as the front monitor type from the operator's position.

Universal clamp

TYPE-Q101-CA+ can clamp both a tight buffer and a loose buffer coating by the standard issue. Please change the position of the coating clamp lid as following procedures according to the kind of the coating.

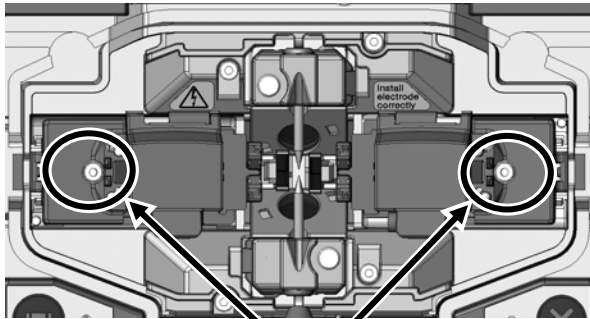

Coating clamp fixation screw

1. Loosen the coating clamp fixation screw, and detach the coating clamp.



Coating clamp

2. The lid can be moved back and forth by opening the coating clamp lid by 180°. Change the position of the lid according to the coating of the fiber, and the shut the lid.

>>Tight buffer : back
>>Loose buffer : forth

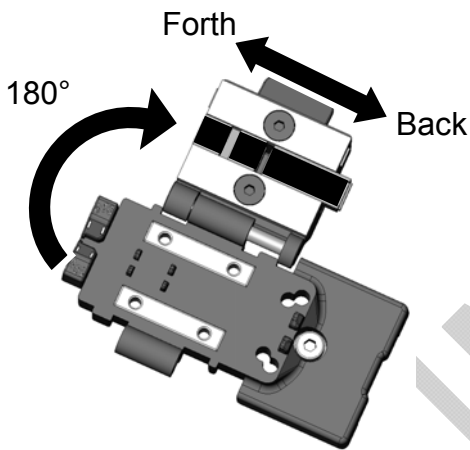

*Please prepare the loose buffer fiber as below.

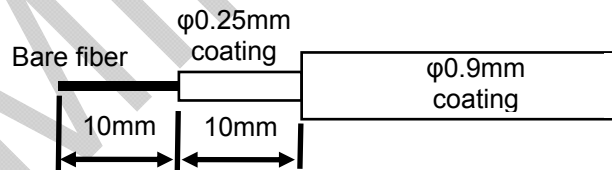

3. Fix the coating clamp back to the splicer.

Dual heat shrink oven

2 heat shrink ovens are equipped with the TYPE-Q101-CA+. These ovens run individually and splicing operation can be improved more effectively.*

* Two ovens can be operated at the same time.

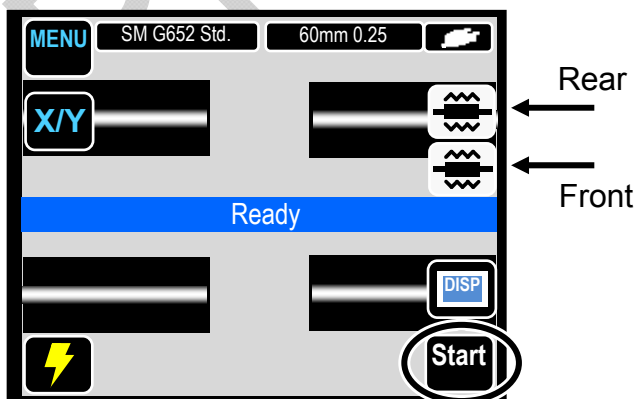

Heat cycle status indicator

The advancement of the heating cycle can be confirmed on the screen. The icon changes as the heating cycle advances.

(Refer to the page 2-20)

Fiber holder operation

By detaching the coating clamp, it is possible to splice by the fiber holder for a single fiber. Fiber holder FHS series made by Sumitomo can be applied.

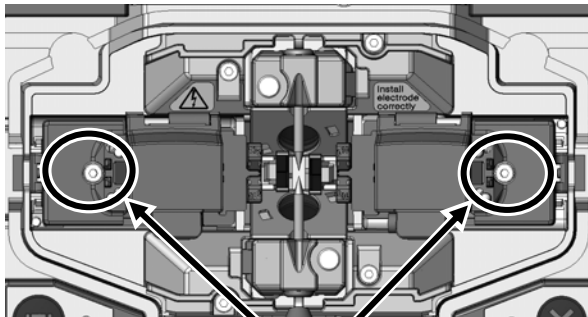

Coating clamp fixation screw

1. Loosen the coating clamp fixation screw, and detach the coating clamp.

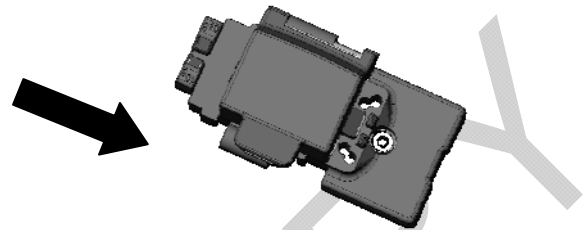

Coating clamp

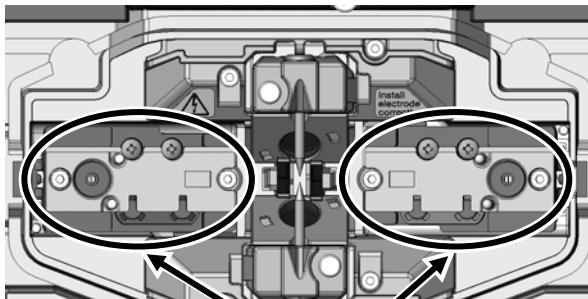

Holder stage

2. The holder stage appears. The fiber holder is set on the holder stage.

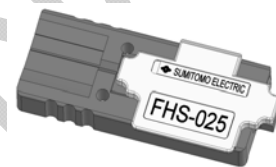

Fiber holder FHS-025

<Fiber holder operation with the back monitor type>

When the fiber holder is used by the back monitor type, change the direction that the fiber holder lid opens by the following procedures.

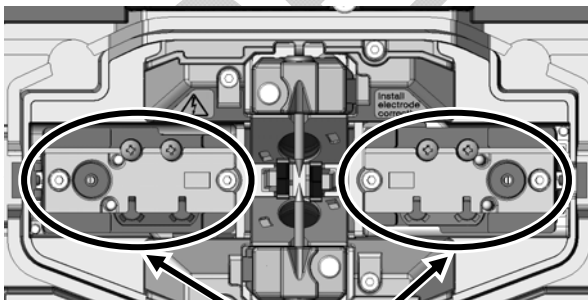

Holder stage

1. Loosen the holder stage fixation screw, and detach the holder stage.

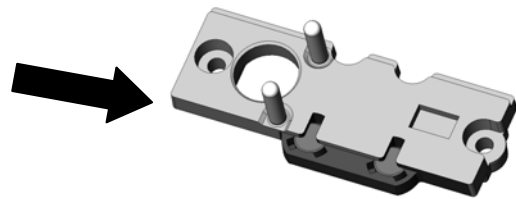

Holder stage

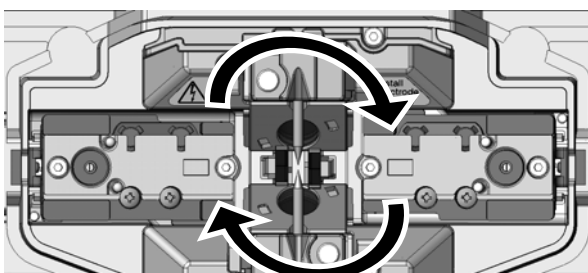

2. After replacing right and left holder stage, tighten the holder stage fixation screw. The lid of the fiber holder opens in the same direction as the front monitor type from the operator's position.

Detachable/attachable bare fiber pads

The bare fiber pad is moved in conjunction with the opening and closing of the hood. It can be separated from the hood to check to see if the fiber is clamped properly. The clamping condition can be corrected independently by moving clamp one by one.

Detaching and attaching bare fiber pads

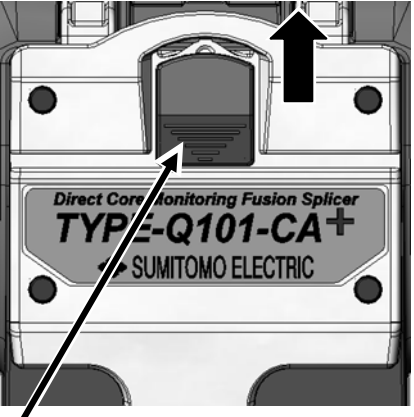
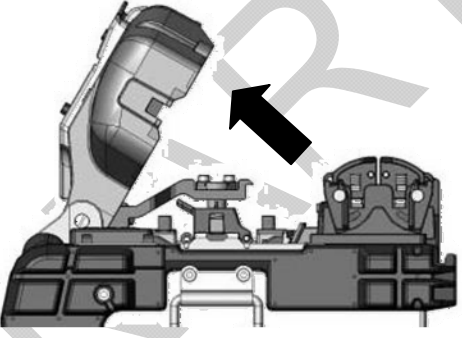
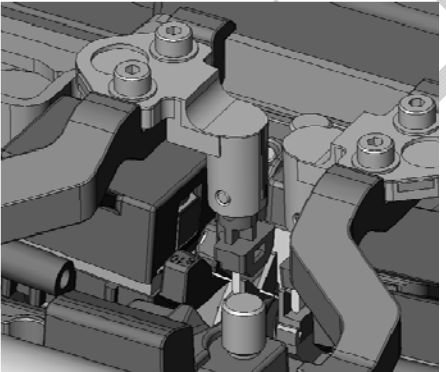
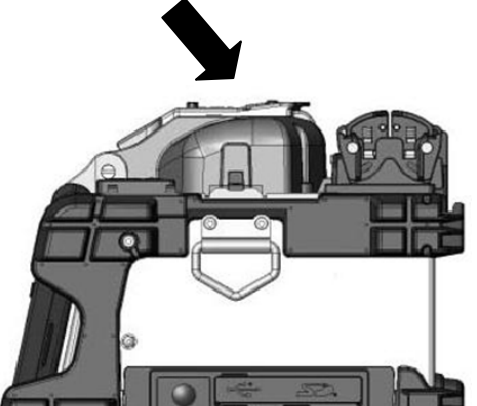
<p>1.</p>  <p>Bare fiber pad release button</p>	<p>2.</p> 
<p>Slide the bare fiber pad release button in the direction indicated by the arrow.</p>	<p>When the hood is opened, the bare fiber pad is removed from the hood.</p>
<p>3.</p> 	<p>4.</p> 
<p>You can check if the fiber is placed seated in the V-groove properly by the pad.</p>	<p>When the hood is closed, the hood catches the bare fiber pad. The hood and the pad are moved together.</p>

Heater clamp operation

Heater lid and heater clamp can be detached, or be synchronized by moving the lever of the heater clamp of both left and right.

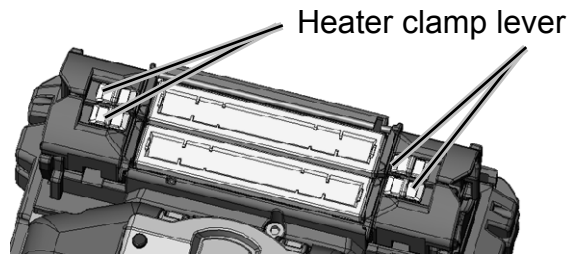



<Changing the operation>

<p>1.</p>	<p>2.</p>
<p>Move the heater clamp lever to the direction of the arrow. *Only right side lever is moved in this example.</p>	<p>The clamp lid and the heater lid move separately.</p>
<p>3.</p> <p>40mm sleeve end</p> <p>Protection sleeve</p>	<p>4.</p>
<p>The position of the protection sleeve can be adjusted by hand when the movement of the heater lid and heater clamp is separated. *40mm sleeve is appeared in this example.</p>	<p>The clamp lid and the heater lid move together by moving the heater clamp lever to the direction of the arrow.</p>

Auto start

The TYPE-Q101-CA+ is provided with Auto start function that automatically starts the splicing process and the heating operation.

Auto start splicing

When the fiber is inserted into the splicer and the hood is closed, the splicing process is automatically started. No need to press () or to touch "start" ().
(See also page 4-13.)

Auto start heating

When the fiber is placed into the heat shrink oven, the heating operation is automatically started. No need to press () or to touch "heat" ().
(See also page 4-13.)

Tripod fixing screws

The TYPE-Q101-CA+ has screw holes for M8 screw and 1/4-20UNC screw. In a high location, fix the splicer to a tripod to prevent it from dropping.

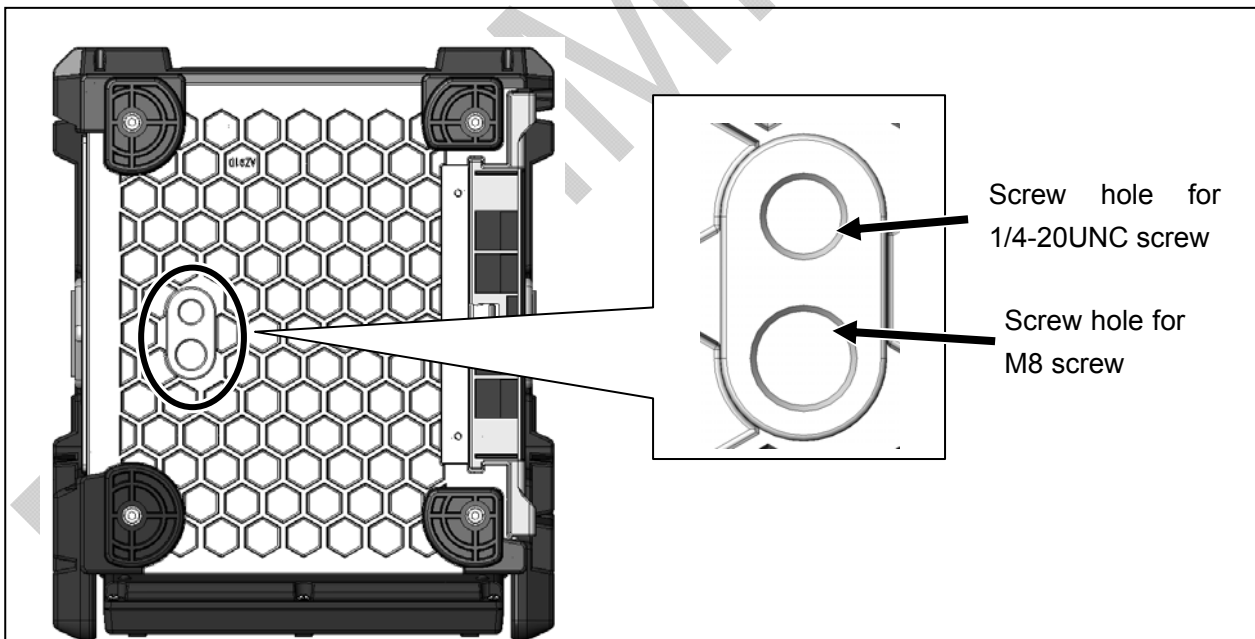

Caution

In a high location, fix the TYPE-Q101-CA+ to a tripod with the M8 screw or 1/4-20UNC screw on the bottom of the splicer to prevent the splicer from dropping.

Hand strap

The strap is attached to TYPE-Q101-CA+. Please install the strap surely according to the following procedure.

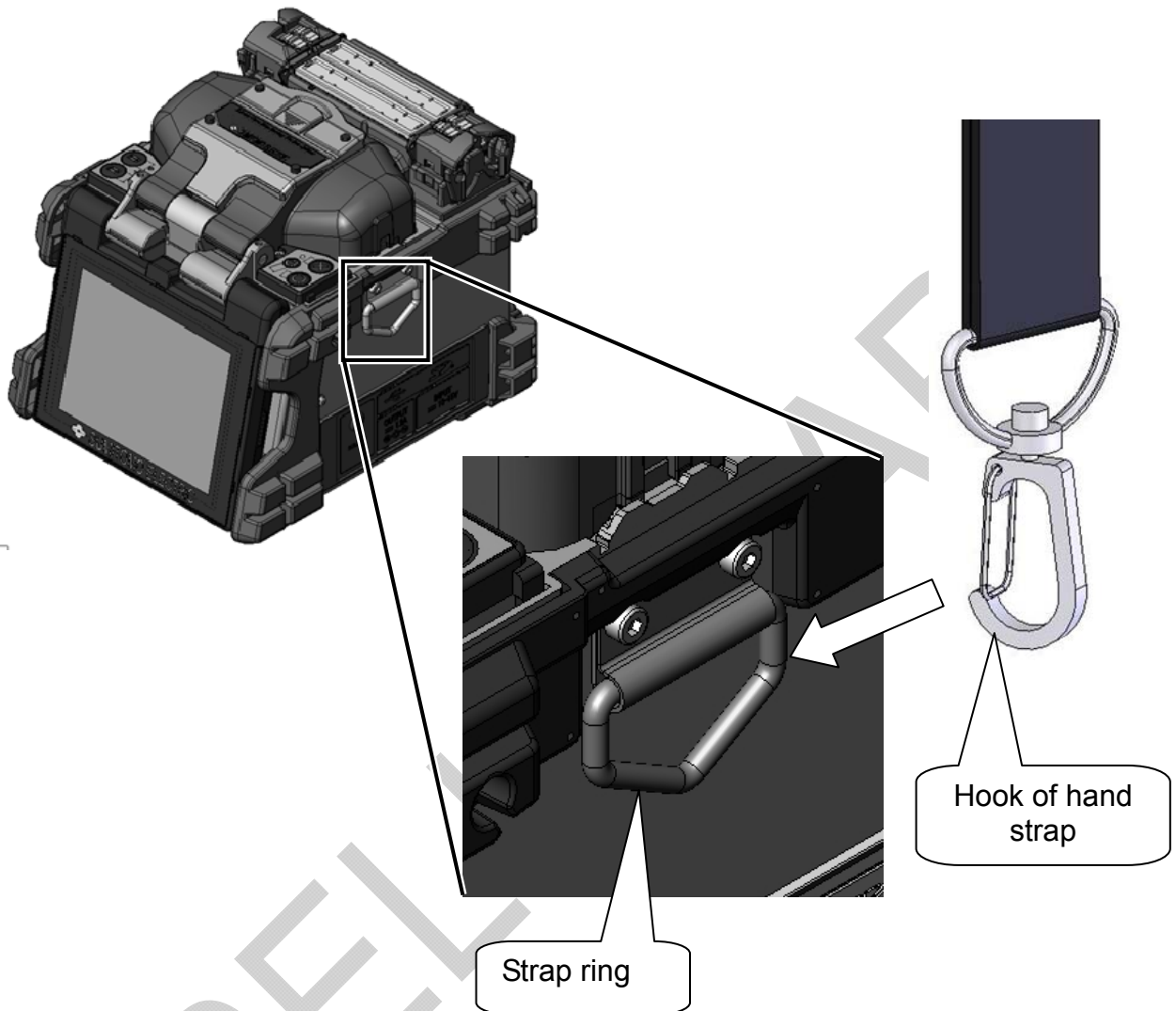

Please pass the hook at both ends of the hand strap through a right and left strap ring of TYPE-Q101-CA+.



If the strap ring is not jointed surely with the hook of the hand strap, TYPE-Q101-CA+ might be dropped.

PRELIMINARY

6. Troubleshooting

For repair and technical support, contact maintenance service center address described in the back cover.

Arc problems

The electrodes typically need replacement after **3000 splices**. Some common symptoms that indicate the electrodes need replacing are:

- High or inconsistent splice losses
- Bubbles in the fibers after splicing
- Diameter faults
- Fluttering or unstable arc observed on the monitor
- Fiber burned in half
- Sizzling noise while arcing

Refer to page 3-6, "Electrode replacement procedures".

If an electrode tip touches something, it will be deformed, causing poor arcing problems. Take care of the handling of electrodes.

Fiber breaking

When the splicing process is complete, a proof test may be performed on the fibers while in the fiber chucks. If the fibers are breaking when the proof test is performed, re-do an arc test. If the arc power level is too weak, the splice may be poor, resulting in fiber breaking.

If the fibers are breaking in spite of a good arc test result, clean the V-grooves and the bare fiber pads completely. Deterioration of a jacket remover/fiber cleaver may lead to fiber breaking. Clean the jacket remover/fiber cleaver completely.

Splicer does not power up

If the fusion splicer fails to turn on when the ON key is pressed, check the following:

- Verify that the battery pack is installed in the module bay properly
- Verify that the power plug is seated properly (the power cord is connected to the AC adapter.)
- Verify that the LED of the AC adapter lights up.
- If using battery operation, ensure that the battery is fully charged.

If the splicer still does not power up after checking the above, contact our maintenance service center.

Warranty and repair service

Before requesting a repair, try to locate the problem and identify the cause by referring to “6 Troubleshooting” at page 6-1. If you ensure that your machine is really in need of a repair, contact our maintenance service center.

REGION LIMITATION

This product is sold for the use in a limited sales area (refer to the information which appears on the splicer screen) and the technical support of the product moved out of the said region may be refused or require extra charges.

Warranty period

1. About the warranty period of this product, please ask to the distributor that you purchased the product from.

Services after warranty period

After the warranty period expires, all products may be repaired for a reasonable service charge.

2. The following cases are the exception for repairing and replacing the product free of charge.
 - (1) Damage or malfunction caused by misuse, mishandling, non qualified repair, disassembly, modification, or any other irregular execution
 - (2) Damage or malfunction caused by drop, fall or any other faulty treatment such as to be explained in precautions on this manual.
 - (3) Damage or malfunction caused by actions that are beyond Sumitomo's control including for example, fire, water flood, earthquake, lightening or similar disaster, or any other accident.
 - (4) Damage or malfunction caused by the use of Product in conjunction with accessories, products, or consumables not specified or approved by Sumitomo.
 - (5) Replacement of consumables
 - (6) Travel expense that is charged if a trip for repair is requested by the customer.
 - (7) Damage or malfunction caused by use of batteries and battery chargers not specified or approved by Sumitomo.
 - (8) Products founds corroded due to exposure to water or dew condensation, or cracked or deformed circuit board.
3. The customer shall bear the cost of returning the product to Sumitomo.

Error message list

Please contact maintenance service center when it is not recovered if you take the measures below.

Error message	Countermeasure
The fibers are not placed correctly in the splicer.	Make sure that the right and left fibers are placed in the correct position of the splicer. >Refer to page 2-12
The splicer failed to adjust the LED brightness.	Clean the microscope lens protection glass and LEDs. >Refer to page 3-2 and 3-3
The splicer is unable to start splicing because the hood is open.	Close the hood. Very high voltage is generated with the splicing. The splicer never starts splicing with opening hood for safety.
The splicer could not detect the left (right) fiber.	Make sure that the left (right) fiber is placed in the correct position of the splicer. >Refer to page 2-12
The splicer failed to align the left (right) fiber.	Make sure that the left (right) fiber is placed in the correct position of the splicer. >Refer to page 2-12 There is a possibility that dust or dirt is on the V-groove and the fiber clamp when the error occurs repeatedly. Please execute the cleaning. >Refer to page 3-2 and 3-3
The splicer failed to adjust the arc gap of the left (right) fiber.	
The splicer failed to inspect the right and left fibers.	Make sure that the right and left fibers are placed in the correct position of the splicer. >Refer to page 2-12
The cleave angle of the left (right) fiber exceeds the allowable limit.	Cleave the left (right) fiber again. >Refer to page 2-10 If the error occurs repeatedly, the cleaver blade might be deteriorated. Change the blade position or replace the blade. For further information, refer to the operation manual of the cleaver.
A lip is observed on the left (right) fiber end.	
A chip is observed on the left (right) fiber end.	
The splicer failed to adjust the focus.	Make sure that the right and left fibers are placed in the correct position of the splicer. >Refer to page 2-12 Also, please confirm whether dust is on the fiber. There is a possibility that dust or dirt is on the V-groove and the fiber clamp when the error occurs repeatedly. Please execute the cleaning. >Refer to page 3-2 and 3-3
The splicer failed to splice the fibers.	Start the splice again.

[TYPE-Q101-CA+ specifications]

Optical fiber requirement	Material	Silica glass		
	Profile types	SMF (ITU-T G.652), MMF (ITU-T G.651) DSF (ITU-T G.653), CSF (ITU-T G.654), NZDSF (ITU-T G.655, G.656), BIF (ITU-T G.657), EDF		
	Cable types	Drop cable, Small-sized indoor cable		
	Fiber diameter	80 – 150 μm		
	Fiber coating diameter	100 – 1,000 μm		
	Cleave length ^{*1}	<up to φ1,000 μm> 5 – 16 mm	<Drop cable / Indoor cable> 10mm	
	Fiber count	Single fiber		
Size and weight	Size (main body) ^{*2}	120W × 154D × 130H (mm)		
	Weight	Approx. 2.1 kg (with BU-11)		
	Monitor	4.1" touch screen color LCD display		
Standard performance	Typical splice loss ^{*3}	SMF : 0.02dB DSF : 0.04dB MMF : 0.01dB NZDSF : 0.04dB		
	Typical splice cycle time ^{*3}	Approx. 6 seconds (SM G652 Quick) Approx. 7 seconds (SM G652 Std.) Approx. 8 seconds (Auto)		
	Typical heating time ^{*4}	Approx. 14 seconds (Slim 60mm 0.25 Quick)		
	Splicing/heating operation per fully charged battery ^{*5}	Approx. 200		
Functions	Loss Estimation	Provided		
	Splice data storage	10,000 splices		
	Splice image capture	200 splices		
	Proof test ^{*6}	Proof load 1.96~2.09N		
	Arc environment calibration	Automatically compensates for environmental condition changes		
	Heat shrink oven	Dual automatic independent heaters		
	Universal clamps for tight & loose buffer fiber	Provided		
	Reversible coating clamps	Provided		
	V-groove white LED illumination	Provided		
	Interface	USB 2.0 mini-B type		
	Storage media	SD / SDHC memory card		
	Wireless LAN feature ^{*7}	Wireless LAN SD card "WLSD-0208 (Option)" is required.		
	Onboard user training video	Provided		
	Software update	Internet		
	Remote interactive maintenance	Provided		
Programs	Splice programs	Max. 300		
	Heating programs	Max. 100		
Power supply	AC operation	With ADC-1430S Input: AC 100-240V 50/60Hz 1.1A		
	DC operation	Input: DC 10-15V, 4.5A		
	Battery operation	(With BU-11) 11.1V (4600mAh)		
	DC output	12V For Sumitomo's hot jacket remover		
Environmental conditions	Operation temperature ^{*8}	-10 °C ~ +50 °C		
	Storage temperature ^{*8 *9}	-40 °C ~ +80 °C		
	Altitude	0 to 6,000m		
	Windproof	Max. 15m/s		
	Water & Dust resistance	Equivalent to IP52 ^{*10}		
	Shock resistance	Drop from 76cm on 5 faces ^{*11}		
Electrode life	3,000 arc discharges ^{*12}			

- *1 The applicable fiber protection sleeves vary depending on the cleave length.
60mm fiber protection sleeves •••• Cleave length 5-16mm
40mm fiber protection sleeves •••• Cleave length 5-10mm
- *2 The protrusion part is not included.
- *3 With Sumitomo identical SMF(ITU-T G.652) in room temperature. Varies depending on the condition of fiber.
- *4 With the AC adapter in room temperature (20°C) and DC output port not in use. If the battery pack is used, the heating time varies depending on the temperature and the remaining battery capacity.
With Sumitomo protection sleeve FPS-61-2.6. Coating diameter 250µm.
- *5 In room temperature (20°C), with a new battery pack, 1 splice cycle time (splice + protection) completes in 90 seconds, in room temperature. Splice & heat cycles may vary depending on the operating environment.
- *6 Performed on the fiber stage after splicing.
- *7 Smartphone application for Android "SumiFi" is required.
- *8 Non-condensing
- *9 The Battery pack storage temperature range: -20°C ~ +50°C (if stored for less than 1 month),
-20°C ~ +40°C (if stored for less than 3 months), -20°C ~ +20°C (if stored for less than 1 year).
- *10 Water resistance: Operates normally after being exposed to water dripping at 3mm/min, for at least 2.5 min on each of 4 surfaces tilted at 15°. The test is held with the battery operation, carried out by Sumitomo, but does not guarantee that the product is free of faults or damage.
Dust resistance: Operates normally after 8 hours in a dust chamber containing dust of particle size 75µm or below. The test is held with the battery operation, carried out by Sumitomo, but does not guarantee that the product is free of faults or damage.
- *11 The machine spliced the fiber successfully after dropped from 76cm height on 5 faces (excluding top face) at free-fall. The test is held with the battery operation, carried out by Sumitomo, but does not guarantee that the product is free of faults or damage.
- *12 Electrode life is not guaranteed. This number may vary depending on the operating environment.

PRELIMINARY

Tokyo (JAPAN)
Sumitomo Electric Industries, Ltd.
(Global Business Dept.)
Akasaka Center Building, 1-3-13, Motoakasaka,
Minato-ku, Tokyo
107-8468, JAPAN
Tel: +81 (0)3 6406 2666
<http://global-sei.com/ftx/>

North Carolina (U.S.A)
Sumitomo Electric Lightwave Corp.
78 Alexander Drive, P.O. Box 13445,
Research Triangle park,
NC27709 U.S.A
Toll Free No. 800 358 7378
Tel: +1 919 541 8100
<http://www.sumitomoelectric.com>

London (U.K)
Sumitomo Electric Europe Ltd.
220 Centennial Park, Centennial Avenue,
Elstree, Herts, WD6 3SL, U.K.
Tel: +44 (0)20 8953 8118
<http://www.sumielectric.com>

Hong Kong (China)
Sumitomo Electric Asia, Ltd.
Tel: +852 2576 0080
<http://www.seac-cn.com/>

Shenzhen (China)
SUMIDEN ASIA (SHENZHEN) Co.,Ltd.
(Beijing Branch)
Tel: +86 755 8270 6880
<http://www.seac-cn.com/>

Beijing (China)
SUMIDEN ASIA (SHENZHEN) Co.,Ltd.
(Beijing Branch)
Tel: +86 10 6590 8196
<http://www.seac-cn.com/>

Shanghai (China)
SUMIDEN ASIA (SHENZHEN) Co.,Ltd.
(Shanghai Branch)
Tel: +86 21 6235 1036
<http://www.seac-cn.com/>

Wuhan (China)
SUMIDEN ASIA (SHENZHEN) Co.,Ltd.
(Wuhan Branch)
Tel: +86 27 8760 6686
<http://www.seac-cn.com/>

Bangkok (Thailand)
Sumitomo Electric (Thailand) Limited
Tel: +66 (0)2 260 7231 to 5
<http://www.set-th.com/>

Singapore
**Sumitomo Electric Interconnect
Products (Singapore) Pte.,Ltd.**
Tel: +65 6261 3388
<http://www.seps.com.sg/>

Dubai (U.A.E.)
Middle East office
Tel: +971 4 701 7338 to 7341

Gurgaon (India)
SEI Trading India Pvt. Ltd. (SETI)
Tel: +91 124 4577 470

Manila (Philippines)
SEI (PHILIPPINES) INCORPORATED
Tel: +63 2 811 2755/2756