Sumitomo Cable Specification

SE-*DB

DriTube[®] Ribbon / Armorlux[™] Sheath Cable

100% Dry - Armored Central Tube Ribbon Cable with 12 - 576 Fibers

Issued: January 2014



78 Alexander Drive, Research Triangle Park, NC 27709
Phone (919) 541-8100, Fax (919) 541-8265
WWW.SUMITOMOELECTRIC.COM

CONTENTS

1.	General	2
1.1	Cable Description	2
1.2	Quality	2
1.3	Reliability	2
2.	Cable Design	3
2.1	General.....	3
2.2	Fiber Types	3
2.3	Optical Fiber Color Code	4
2.4	Ribbon Matrices	4
2.5	Central Buffer Tube.....	5
2.6	Cable Water Blocking.....	5
2.7	Cable Sheath	5
2.8	Cable Dimensions.....	6
2.9	Sheath Marking.....	6
3.	Cable Performance	7
4.	Testing and Inspection	8
5.	Packaging and Shipping	8
6.	Installation / Handling Practices	9
7.	Ordering Information	10

1. GENERAL

This specification covers the design requirements and performance standards for the supply of optical fiber cables as described below. The features described in this document are intended to provide information on the performance of Sumitomo Electric Lightwave's optical cable and aid in handling and installation. Please refer to the separate fiber specification for details regarding the optical fiber.

1.1 Cable Description

Sumitomo's Armored DriTube Ribbon cables contain 12 to 576 optical fibers. The fibers are grouped into 12 or 24 fiber flat ribbon matrices. Water blocking yarns are applied around a stack of optical fiber ribbons in a single central buffer tube. Water blocking tape, wrapped around the tube, also provides protection against water migration down the cable. There is no water blocking gel used in the construction of this cable. Corrugated steel armor is placed around the water blocking tape and buffer tube with a ripcord underneath for easy sheath removal. Two steel wires are longitudinally laid down each side of the armor for tensile strength. Highly visible ripcords are placed along each group of strength elements for quick sheath entry. A smooth black medium density polyethylene (MDPE) sheath is extruded over the armored core and wires.

Recommended applications include lashed, buried innerduct and direct buried. Sumitomo's DriTube cables are qualified against Telcordia GR-20-CORE and meet all of the requirements of RUS (formally REA) 7 CFR 1755.900.

1.2 Quality

Sumitomo ensures a high level of quality through ISO / TL 9000 registered Quality Management Systems and our commitment to continuous improvement. Guaranteed, high quality products have been manufactured at Sumitomo's facility in Research Triangle Park, North Carolina since 1984.

1.3 Reliability

Sumitomo ensures product reliability through rigorous qualification testing of each product family to meet or exceed industry standards. Both initial and periodic qualification testing are performed to assure the cable's performance and durability in the field environment.

Sumitomo supports industry standards organizations such as Bell Communications Research (Bellcore), Telecommunications Industry Association (TIA), International Telecommunications Union (ITU), International Electrotechnical Commission (IEC), American Society for Testing and Materials (ASTM), Rural Utilities Service (RUS), The Institute of Electrical and Electronics Engineers (IEEE), and Insulated Cable Engineers Association (ICEA).

2. CABLE DESIGN

2.1 General

Sumitomo's DriTube™ Ribbon / Armorlux sheath optical cables utilize 12 or 24 fiber ribbons within a central tube construction which provides a small diameter, lightweight, high fiber packing density cable. The steel armored sheath construction produces a rugged, rodent resistant cable, ideal for direct buried or lashed aerial installations.

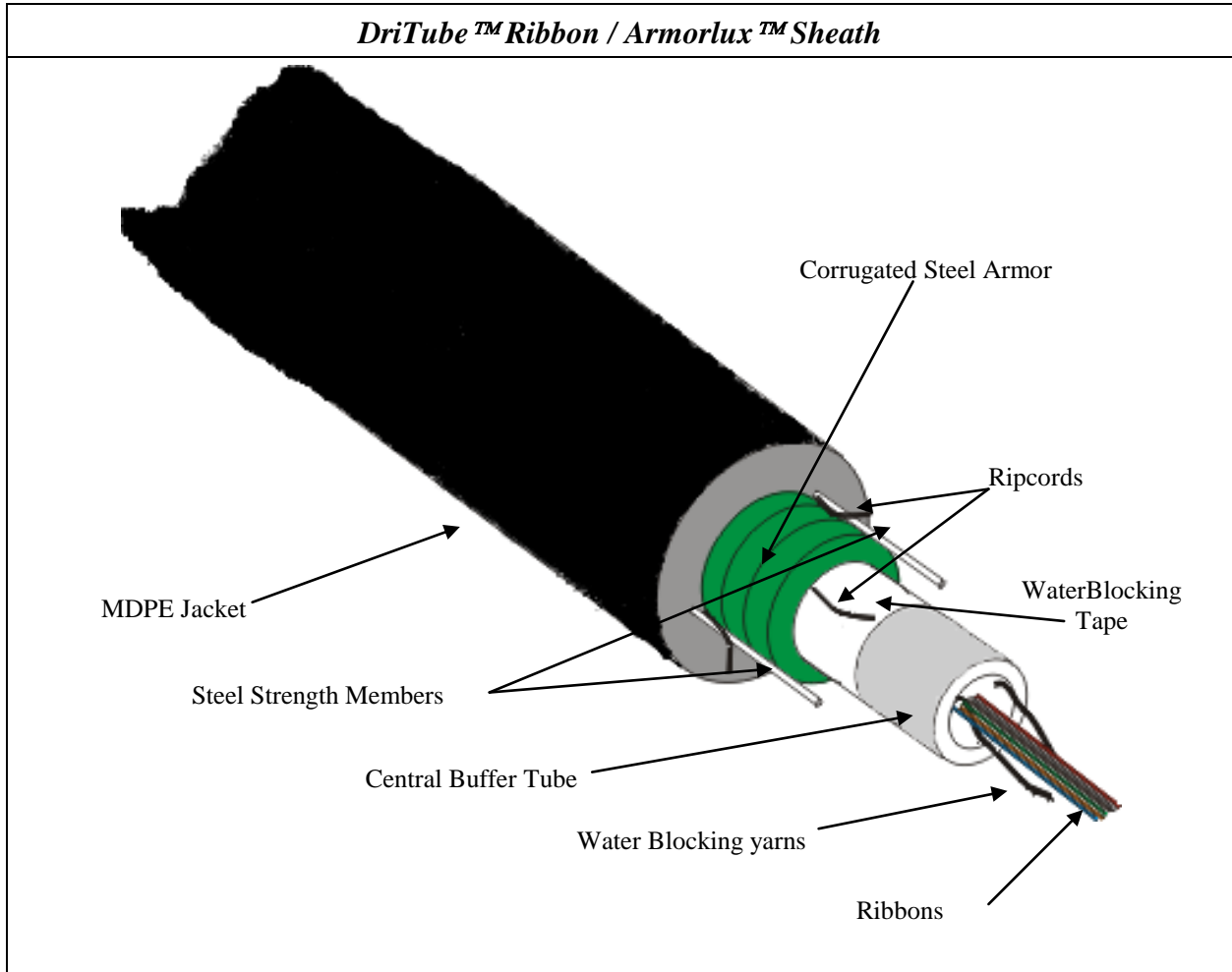

2.2 Fiber Types

The following fiber types are available in this cable design. Please refer to the appropriate fiber specification document for details on fiber design and performance.

<i>APPLICABLE FIBER TYPES</i>		
FIBER TYPE	TIA CLASS	SUMITOMO SPEC. #
PureBand – Low Water Peak Attenuation	Type IVa	SE-5**

2.3 Optical Fiber Color Code

The UV acrylate coated fibers are color coded with highly distinguishable, vibrant colors according to the following table. All colors meet Munsell standards as specified in TIA-359 and TIA-598.

2.4 Ribbon Matrices

Twelve (12) individually color coded fibers are held together in the form of a flat ribbon by an UV cured acrylate matrix. Fibers within the ribbon are arranged in the order shown in the table below. Each ribbon within the cable is marked with “SUMITOMO” and a unique identification number and code as shown below. For cables with greater than 216 fibers, the 12 fiber ribbons are formed together into 24 fiber ribbons. These 24 fiber ribbons can easily split apart into two 12-fiber ribbons for easy handling and splicing.

The optical fiber ribbons are fully compatible with Sumitomo's mass fusion splicing equipment and other commercially available splicing techniques. The matrix and coatings are easily stripped with thermal strippers. The matrix material can also be easily and cleanly pulled away from the individual 250 μm colored fibers if single fiber access is needed from the ribbon end or in midspan using Sumitomo's ribbon midspan access kit (MA-2 Ribbon Access Kit).

FIBER COLOR CODE	
FIBER #	COLOR
1	Blue
2	Orange
3	Green
4	Brown
5	Slate
6	White
7	Red
8	Black
9	Yellow
10	Violet
11	Rose
12	Aqua

RIBBON MARKING CODES			
RIBBON #	CODE	RIBBON #	CODE
1	BL 1	19	D-RD 19
2	OR 2	20	D-BK 20
3	GR 3	21	D-YL 21
4	BR 4	22	D-VI 22
5	SL 5	23	D-RS 23
6	WH 6	24	D-AQ 24
7	RD 7	25	DD-BL 25
8	BK 8	26	DD-OR 26
9	YL 9	27	DD-GR 27
10	VI 10	28	DD-BR 28
11	RS 11	29	DD-SL 29
12	AQ 12	30	DD-WH 30
13	D-BL 13	31	DD-RD 31
14	D-OR 14	32	DD-BK 32
15	D-GR 15	33	DD-YL 33
16	D-BR 16	34	DD-VI 34
17	D-SL 17	35	DD-RS 35
18	D-WH 18	36	DD-AQ 36

SUMTOMO OPTICAL FIBER RIBBON

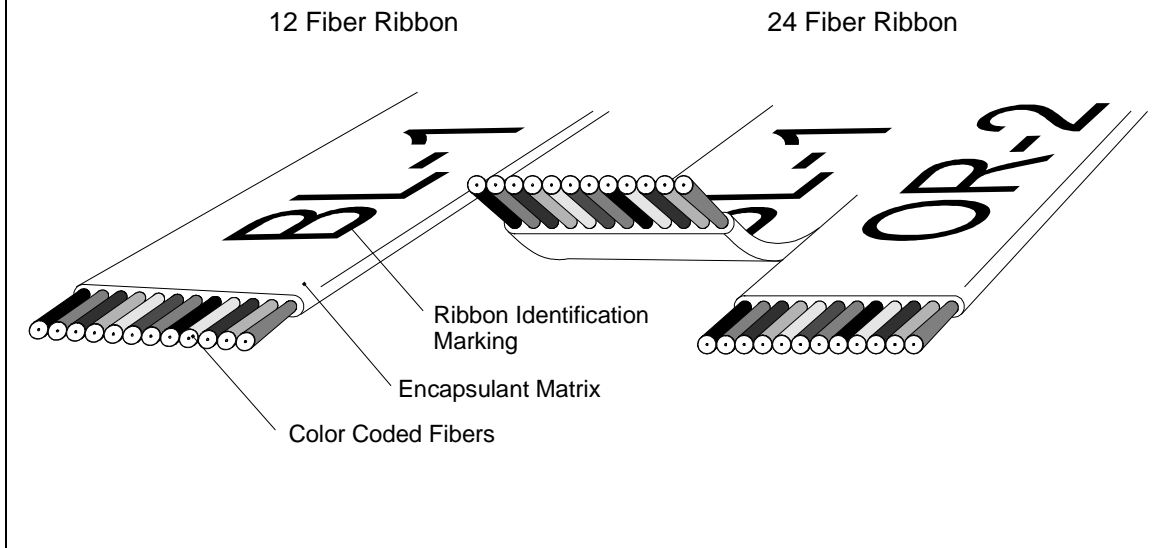

2.5 Central Buffer Tube

Water blocking yarns are applied around a stack of optical fiber ribbons in a single buffer tube. The water blocking yarns prevent water migration down the tube and can be easily removed from the tube during cable splice preparation without the use of chemicals or cleaning solutions. The buffer tube is made of a semi-translucent thermo-plastic material.

2.6 Cable Water Blocking

The central buffer tube is wrapped with a water absorbing tape to prevent the migration of water through the cable. The dry tape does not adhere to the tube and is easily removed during cable splice preparation.

2.7 Cable Sheath

The Armorlux cable sheath consists of a corrugated co-polymer coated steel tape wrapped around the central buffer tube. This steel armor provides additional cable compression strength and rodent protection. Aramid ripcords are placed under the armor to facilitate its removal.

Two steel wires are longitudinally laid 180° opposed along the outside of the armor. They provide the cable with the necessary tensile strength for installation and service loads. Highly visible ripcords are placed along each steel wire for quick and easy sheath entry.

The armor and steel wires are covered with a smooth outer black MDPE jacket.

2.8 Cable Dimensions

<i>LITEPIPE DRITUBE™ RIBBON / ARMORLUX™ SHEATH CABLE</i>		
FIBER COUNT	NOMINAL DIAMETER	NOMINAL WEIGHT
12 – 48	12.1 mm (0.48 in)	138 Kg/km (93 lbs/kft)
60 – 96	14.7 mm (0.58 in)	208 Kg/km (140 lbs/kft)
108 – 144	16.2 mm (0.64 in)	252 Kg/km (169 lbs/kft)
156 – 216	20.4 mm (0.80 in)	314 Kg/km (211 lbs/kft)
240 – 288	21.9 mm (0.86 in)	371 Kg/km (249 lbs/kft)
312 – 432	24.6 mm (0.97 in)	425 Kg/km (286 lbs/kft)
456 – 576	27.3 mm (1.08 in.)	507 Kg/km (341 lbs/kft)

2.9 Sheath Marking

The entire length of each cable is marked with the following items:

- "SUMITOMO OPTICAL CABLE"
- Month and Year of Manufacture
- Number of Optical Fibers
- Sequential Length Markings in feet (optional meters)
- Telephone Handset Symbol per Section 350G, NESC

All length markings are placed at two-foot intervals. The actual cable length will be within +1%, -0% of the marked length. All markings are in indented in permanent white characters. If remarking is required, yellow markings are used to correct the error in the original markings.

3. CABLE PERFORMANCE

The finished cables can be subjected to the following mechanical and environmental conditions without a permanent increase in attenuation or damage to the cable.

MECHANICAL PERFORMANCE		TEST	SPECIFICATION	REF.
PROPERTY		PROCEDURE		
Low and High Temperature Cable Bend		EIA/TIA-455-37	20 x cable O.D. @ -30°C and 60°C	1
Impact Resistance		EIA/TIA-455-25	25 impact cycles	1
Compressive Strength		EIA/TIA-455-41	440 N/cm (248 lbs/in.)	1
Maximum Tensile Load:	During Installation	EIA/TIA-455-33	2700 N (600 lbs)	1
	During Service		890 N (200 lbs)	
Cable Twist		EIA/TIA-455-85	2 meter length \pm 180°	1
Cable Cyclic Flexing		EIA/TIA-455-104	20 x cable O.D. 25 cycles	1
Minimum Bend Radius:	During Installation	EIA/TIA-455-37	20 x cable O.D.	1
	During Service		10 x cable O.D.	
Gopher Resistance		Telcordia GR-20	Index Rating \leq 3	1

ENVIRONMENTAL PERFORMANCE		TEST	SPECIFICATION	REF.
PROPERTY		PROCEDURE		
Temperature:	Operation	EIA/TIA-455-3	-40 to +70 °C (-40 to +158 °F)	1
	Installation		-30 to +60 °C (-22 to +140 °F)	
	Storage / Shipping		-40 to +75 °C (-40 to +167 °F)	
Cable Aging		EIA/TIA-455-3	168 hours @ 85°C	1
Cable Freezing		EIA/TIA-455-98	Frozen in Ice	1
Water Penetration		EIA/TIA-455-82	1 meter for 24 hours	1
Compound Drip Temperature		EIA/TIA-455-81	Not Applicable	1
Wasp Spray Exposure		Telcordia GR-20	No Deterioration	1
Color Coding Permanence		Telcordia GR-20	Colors are Stable after Aging	1
Lighting Damage Susceptibility		EIA/TIA-455-181	Exceeds Category 1	1
Current Carrying Capacity		Telcordia GR-20	60 Amp, 60Hz	1

4. TESTING AND INSPECTION

The optical properties of all fibers are measured prior to cable manufacturing and remain traceable throughout the manufacturing process and the lifetime of the cable.

After cabling, we use statistical process control techniques along with periodic verification to insure 100% compliance to attenuation requirements in each length of cable with bi-directional OTDR at all operating wavelengths. Cable dimensional measurements are also made at final inspection and recorded.

5. PACKAGING AND SHIPPING

Cable is supplied in lengths specified at the time of purchase. Each length will be shipped on a separate non-returnable wooden reel or if specified, a returnable steel reel. The minimum barrel diameter of the reel will not be less than 30 times the cable diameter.

The cable on each reel will be completely covered with a thermal wrap which is fastened to the cable by packaging straps. This wrap is reusable and provides excellent thermal and UV protection to cables sitting in reel yards.

The cable ends will be sealed with plastic protection caps to prevent water penetration. The ends will be easily accessible for testing. Optional pulling grips may be factory installed if specified at the time of purchase.

REEL DIMENSIONS							
REEL TYPE	REEL CODE	FLANGE DIAMETER		REEL WIDTH		REEL WEIGHT	
Wood	L-3	850 mm	(34 in.)	580 mm	(23 in.)	32 Kg	(70 lbs)
	L-8	1050 mm	(41 in.)	760 mm	(30 in.)	61 Kg	(134 lbs)
	L-11	1250 mm	(49 in.)	760 mm	(30 in.)	91 Kg	(200 lbs)
	L-15	1350 mm	(53 in.)	910 mm	(36 in.)	106 Kg	(233 lbs)
	L-18	1500 mm	(59 in.)	910 mm	(36 in.)	133 Kg	(293 lbs)
	L-21	1600 mm	(63 in.)	1050 mm	(42 in.)	214 Kg	(471 lbs)
	L-25	1800 mm	(71 in.)	1050 mm	(42 in.)	246 Kg	(541 lbs)
	L-27	1850 mm	(73 in.)	1120 mm	(44 in.)	294 Kg	(647 lbs)
	L-29	1950 mm	(77 in.)	1120 mm	(44 in.)	307 Kg	(676 lbs)
	L-37	2210 mm	(87 in.)	1240 mm	(49 in.)	421 Kg	(927 lbs)
L-46	2440 mm	(96 in.)	1240 mm	(49 in.)	504 Kg	(1108 lbs)	
Steel	414	1270 mm	(50 in.)	810 mm	(32 in.)	109 Kg	(240 lbs)
	415	1420 mm	(56 in.)	810 mm	(32 in.)	130 Kg	(285 lbs)
	416	1680 mm	(66 in.)	810 mm	(32 in.)	155 Kg	(340 lbs)
	417	1980 mm	(78 in.)	840 mm	(33 in.)	241 Kg	(530 lbs)
	420	2130 mm	(84 in.)	1220 mm	(48 in.)	350 Kg	(770 lbs)
	421	2290 mm	(90 in.)	1220 mm	(48 in.)	405 Kg	(890 lbs)
	422	2440 mm	(96 in.)	1220 mm	(48 in.)	539 Kg	(1185 lbs)

Each reel is marked with the manufacturer's name and address, cable type, fiber count, attenuation specs, and cable length. A final inspection test report with attenuation performance data for each fiber is attached to the reel flange along with shipping labels.

REEL USAGE

WOOD STEEL	REEL CODES							[ft.]	[m]	CABLE LENGTH
	L-18 417	L-25 420	L-29 420	L-37 421	L-46 NA	NA NA	NA NA	30,000	9,140	
L-15 416	L-21 417	L-25 420	L-37 420	L-46 422	L-46 NA	NA NA	25,000	7,620		
L-15 416	L-18 417	L-25 420	L-29 420	L-37 421	L-46 422	L-46 NA	20,000	6,100		
L-11 415	L-15 416	L-21 417	L-25 420	L-27 420	L-37 420	L-37 421	15,000	4,570		
L-8 414	L-11 415	L-15 416	L-21 417	L-21 417	L-27 420	L-37 420	10,000	3,050		
L-8 414	L-11 414	L-15 415	L-21 416	L-21 417	L-27 417	L-37 420	7,500	2,290		
L-8 414	L-8 414	L-11 414	L-21 415	L-21 416	L-27 416	L-37 417	5,000	1,520		
L-3 414	L-3 414	L-11 414	L-21 414	L-21 414	L-27 414	L-37 415	2,500	760		
[in.]	0.4	0.5	0.6	0.7	0.8	0.9	1.0			
[mm]	10.2	12.7	15.2	17.8	20.3	22.9	25.4			
CABLE DIAMETER										

NOTE: Actual reel size used will depend on production capacity, net weight, and reel availability. Check with your sales representative for more details.

6. INSTALLATION / HANDLING PRACTICES

Sumitomo has incorporated a wide range of technical support and training services for our fiber optic cable products into our Technical Support Services (TSS) program. TSS offers training in the areas of cable installation, sheath entry, splicing, testing, and system troubleshooting. The services are available in a variety of media formats and can be customized to better accommodate individual training needs. The TSS program consists of an extensive series of recommended procedure documents, training courses with classroom and hands-on instruction, as well as demonstration videotapes. Please contact Sumitomo's Customer Service department for more information.

7. ORDERING INFORMATION

To learn more about Sumitomo's cables or to place an order, call, fax, e-mail, or write us at:

*Sumitomo Electric Lightwave Corp.
78 Alexander Drive
Research Triangle Park, NC 27709
Attn: Customer Service Department*

*Phone: 800-358-7378
919-541-8100
Fax: 919-541-8265
E-mail: info@sumitomoelectric.com*

Sumitomo Electric Lightwave Corp. reserves the right to improve, enhance, or modify the cable's features and specifications. For special requirements different than those shown above, please contact our Inside Sales Department. Each Sumitomo Electric Lightwave Corp. optic cable and/or its manufacture may be covered by one or more of the following US Patents: 4,715,677 4,729,629 4,763,983 4,770,489 4,828,349 4,953,945 5,043,037 5,082,347 5,165,003 D331,567 5,247,599 5,410,901 5,471,555 5,642,452.

Cable and/or its manufacture may be covered by one or more of the following US Patents: 4,715,677 4,729,629 4,763,983 4,770,489 4,828,349 4,953,945 5,043,037 5,082,347 5,165,003 D331,567 5,247,599 5,410,901 5,471,555 5,642,452.